

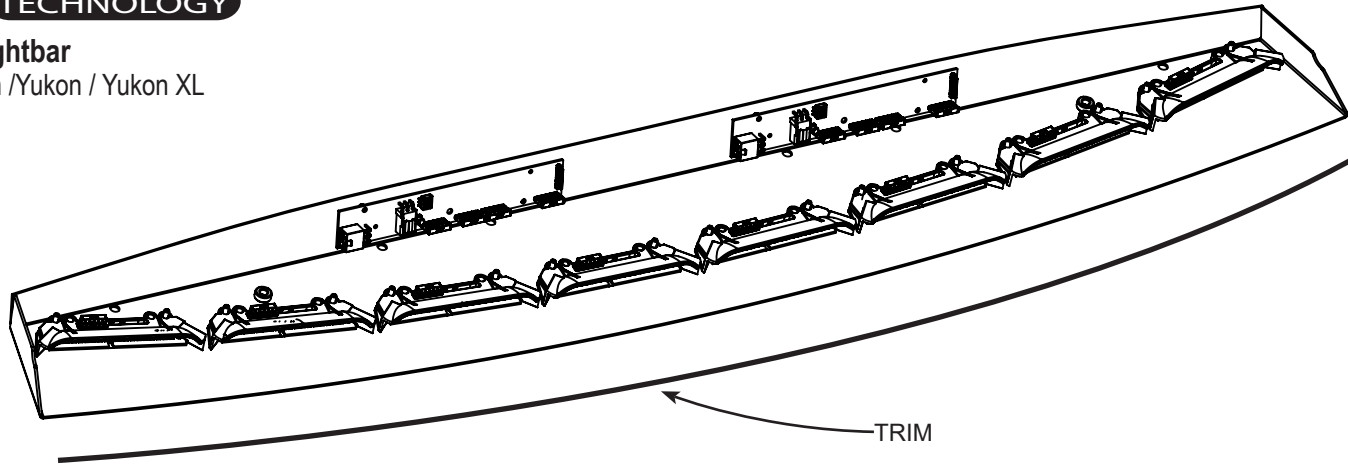

nFORCE LED Interior Lightbar

2015-2020 Tahoe / Suburban / Yukon / Yukon XL
Full (1-Piece) Rear Facing



! WARNING

- HIGH CURRENT interconnects must be properly terminated. Poor crimp quality can cause heat build-up and fire. Follow crimp connector manufacturer instructions.
- DO NOT install this product or route any wires in the Air Bag Deployment Zone. Refer to vehicle Owner's Manual for deployment zones.
- Do NOT use system to disconnect headlights, brake lights or other safety equipment.
- Unit may become hot to touch during normal operation.
- Failure to properly install connectors, fuses or wiring may cause vehicle failure or fire.
- Installation must only be performed by trained technician. Installer must determine vehicle wiring configuration and proper integration of system.
- Use proper wire gauge. All power wires connecting to positive (+) or negative (-) battery terminal or local chassis ground (-) must be sized to supply at least 125% of max. current and properly fused at power source.
- Install protective grommets when routing wire through firewall or metal.

! WARNING
This product contains high intensity LED devices. To prevent eye damage, DO NOT stare into the light beam at close range.

SERVICE PARTS
PNFWBBRFC03 - Rear Facing Shroud w/ Hardware (no mounting brackets)
PNFWBMRFC03 - Rear Facing Mounting Brackets w/ Hardware

OPERATION:
SEE 'ELECTRICAL INSTALLATION' SECTION OF THE nFORCE LED INTERIOR LIGHTBAR INSTALLATION PACKET.

NOTICE:

Installers and users must comply with all applicable federal, state and local laws regarding use and installation of warning devices.

Improper use or installation may void warranty coverage.

To review our Limited Warranty Statement & Return Policy for this or any SoundOff Signal product, visit our website at www.soundoffsignal.com/tech-services/returns/.

If you have questions regarding this product, contact **Technical Services**, Monday - Friday, 8 a.m. to 5 p.m. ET at 1.800.338.7337 (press #4).

Questions or comments that do not require immediate attention may be emailed to techservices@soundoffsignal.com.



1.800.338.7337 / www.soundoffsignal.com

ENHANCING SAFETY THROUGH INNOVATION



nFORCE LED Interior Lightbar
2015-2020 Tahoe / Suburban / Yukon / Yukon XL
Full (1-Piece) Rear Facing

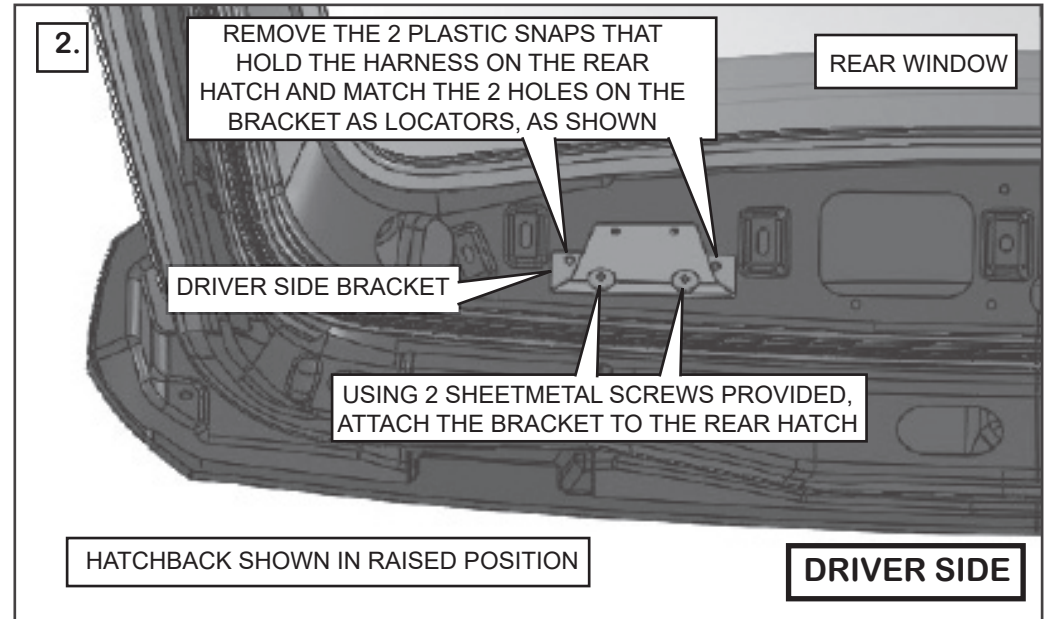
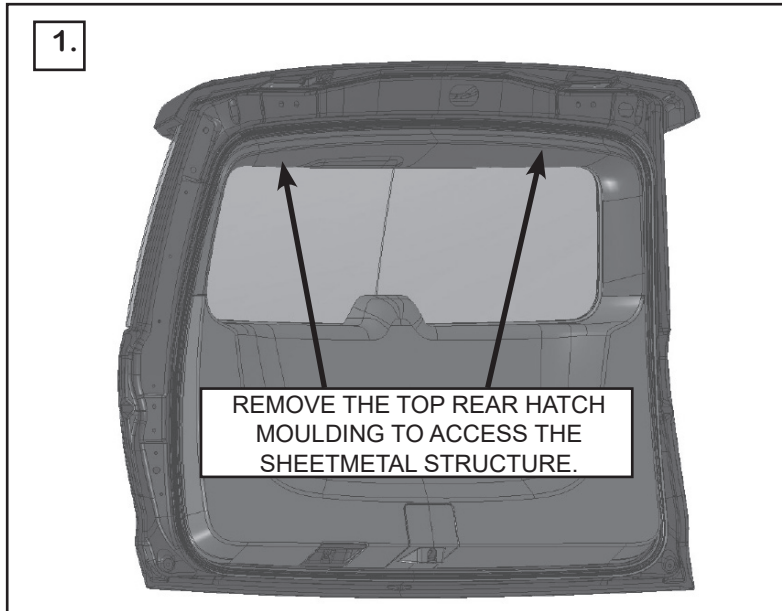

1.800.338.7337 / www.soundoffsignal.com

NOTICE:

Installers and users must comply with all applicable federal, state and local laws regarding use and installation of warning devices.

Improper use or installation may void warranty coverage.

To review our Limited Warranty Statement & Return Policy for this or any SoundOff Signal product, visit our website at www.soundoffsignal.com/tech-services/returns/.

If you have questions regarding this product, contact **Technical Services**, Monday - Friday, 8 a.m. to 5 p.m. ET at 1.800.338.7337 (press #4).

Questions or comments that do not require immediate attention may be emailed to techservices@soundoffsignal.com.

ENHANCING SAFETY THROUGH INNOVATION



nFORCE LED Interior Lightbar

2015-2020 Tahoe / Suburban / Yukon / Yukon XL

Full (1-Piece) Rear Facing

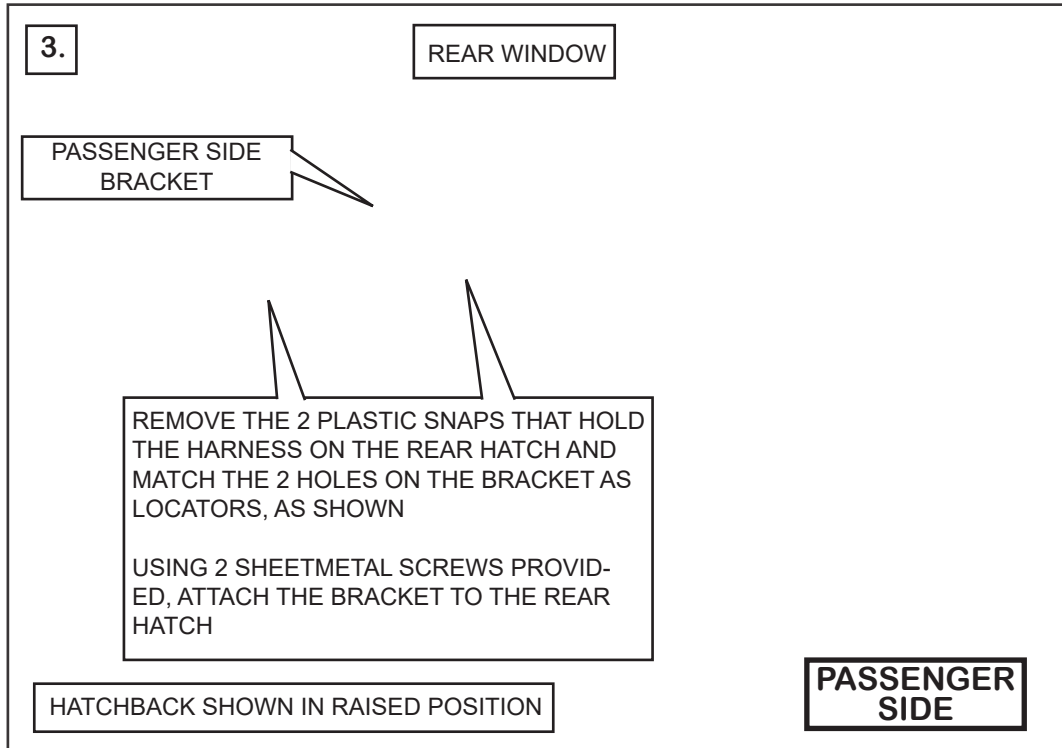

1.800.338.7337 / www.soundoffsignal.com

NOTICE:

Installers and users must comply with all applicable federal, state and local laws regarding use and installation of warning devices.

Improper use or installation may void warranty coverage.

To review our Limited Warranty Statement & Return Policy for this or any SoundOff Signal product, visit our website at www.soundoffsignal.com/tech-services/returns/.

If you have questions regarding this product, contact **Technical Services**, Monday - Friday, 8 a.m. to 5 p.m. ET at 1.800.338.7337 (press #4).

Questions or comments that do not require immediate attention may be emailed to techservices@soundoffsignal.com.

ENHANCING SAFETY THROUGH INNOVATION

nFORCE LED Interior Lightbar
 2015-2020 Tahoe / Suburban / Yukon / Yukon XL
 Full (1-Piece) Rear Facing

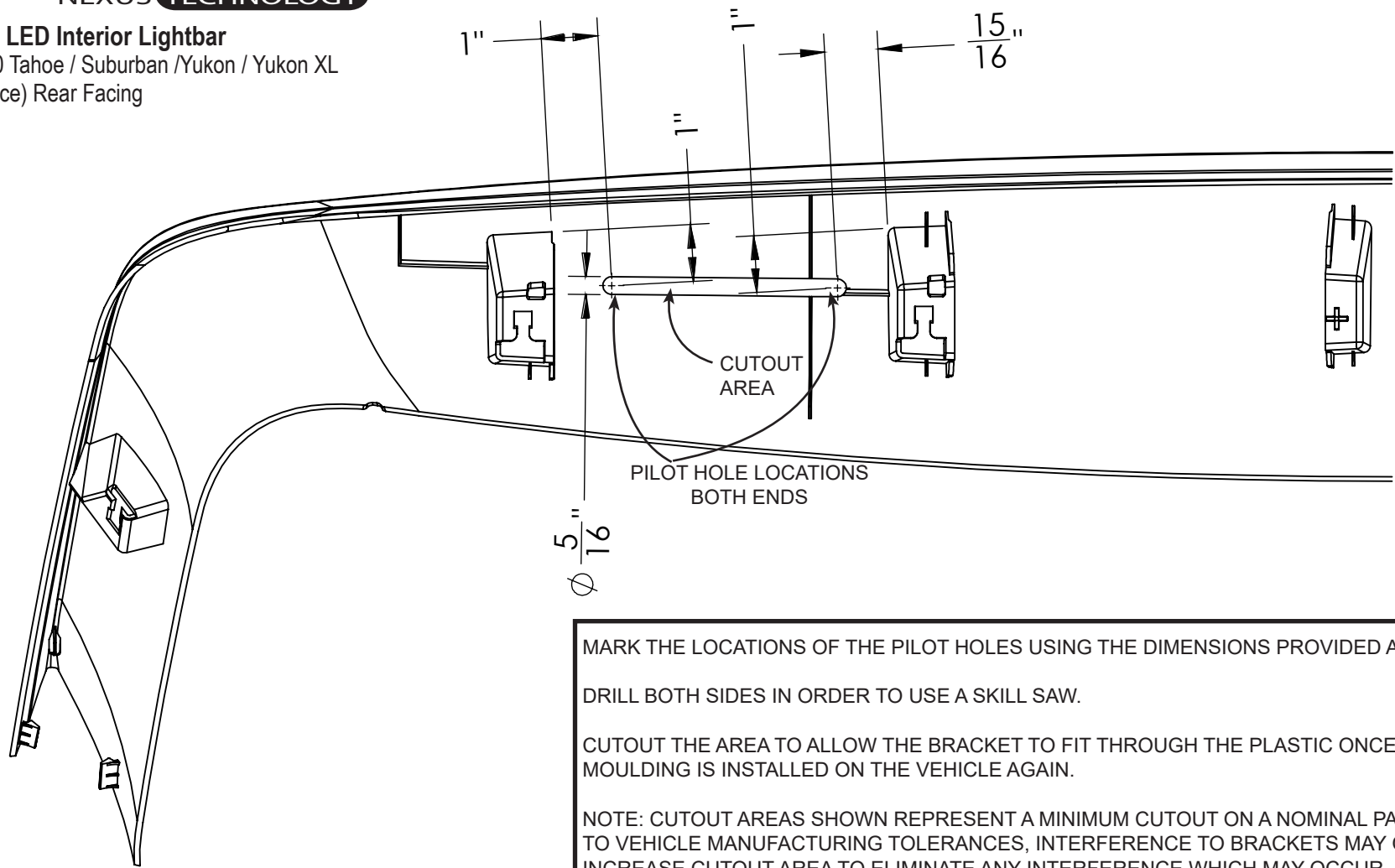

MARK THE LOCATIONS OF THE PILOT HOLES USING THE DIMENSIONS PROVIDED ABOVE.

DRILL BOTH SIDES IN ORDER TO USE A SKILL SAW.

CUTOUT THE AREA TO ALLOW THE BRACKET TO FIT THROUGH THE PLASTIC ONCE THE MOULDING IS INSTALLED ON THE VEHICLE AGAIN.

NOTE: CUTOUT AREAS SHOWN REPRESENT A MINIMUM CUTOUT ON A NOMINAL PART. DUE TO VEHICLE MANUFACTURING TOLERANCES, INTERFERENCE TO BRACKETS MAY OCCUR. INCREASE CUTOUT AREA TO ELIMINATE ANY INTERFERENCE WHICH MAY OCCUR.

NOTICE:

Installers and users must comply with all applicable federal, state and local laws regarding use and installation of warning devices.

Improper use or installation may void warranty coverage.

To review our Limited Warranty Statement & Return Policy for this or any SoundOff Signal product, visit our website at www.soundoffsignal.com/tech-services/returns/.

If you have questions regarding this product, contact **Technical Services**, Monday - Friday, 8 a.m. to 5 p.m. ET at **1.800.338.7337** (press #4).

Questions or comments that do not require immediate attention may be emailed to techservices@soundoffsignal.com.

nFORCE LED Interior Lightbar
2015-2020 Tahoe / Suburban / Yukon / Yukon XL
Full (1-Piece) Rear Facing

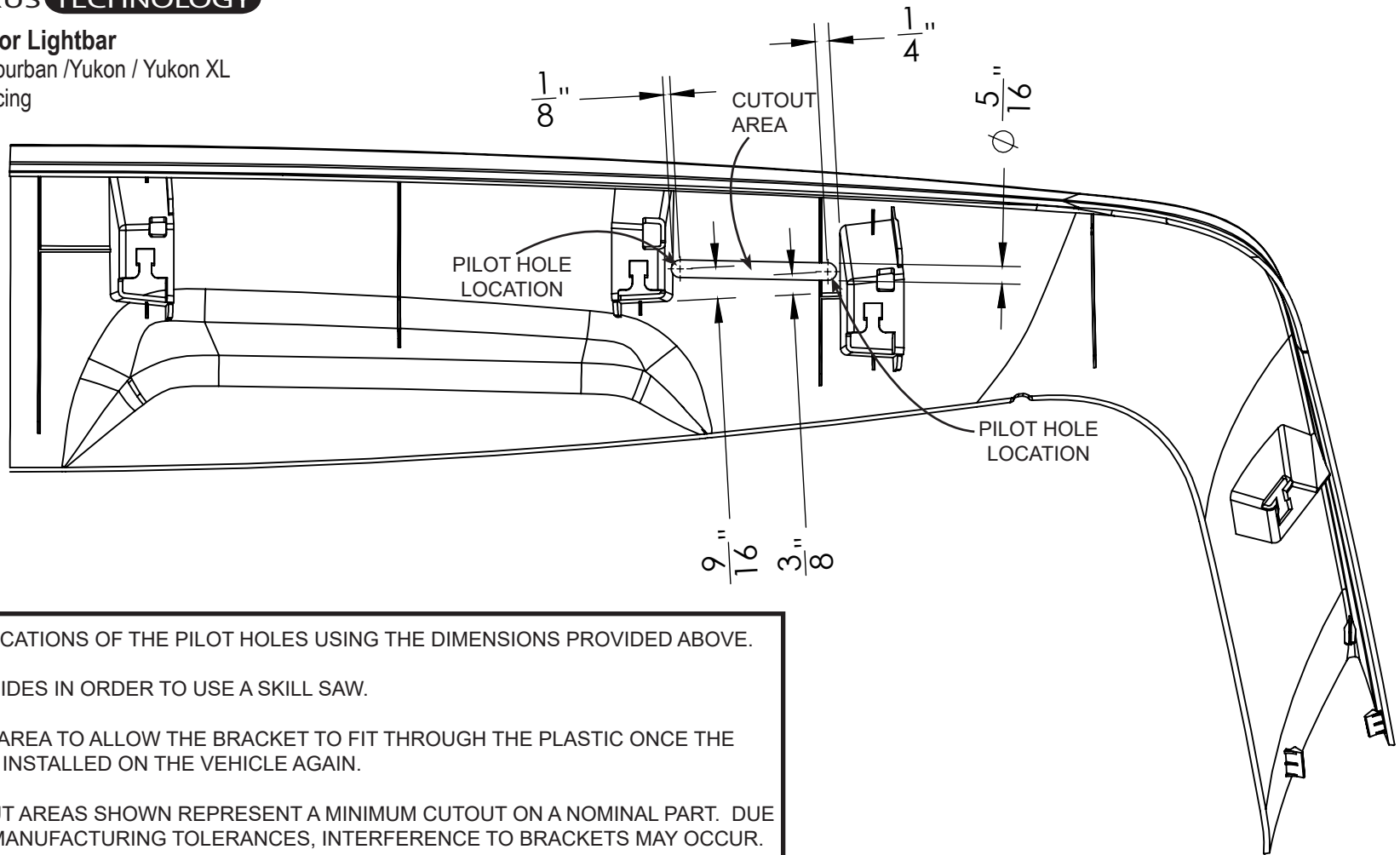

MARK THE LOCATIONS OF THE PILOT HOLES USING THE DIMENSIONS PROVIDED ABOVE.

DRILL BOTH SIDES IN ORDER TO USE A SKILL SAW.

CUTOUT THE AREA TO ALLOW THE BRACKET TO FIT THROUGH THE PLASTIC ONCE THE MOULDING IS INSTALLED ON THE VEHICLE AGAIN.

NOTE: CUTOUT AREAS SHOWN REPRESENT A MINIMUM CUTOUT ON A NOMINAL PART. DUE TO VEHICLE MANUFACTURING TOLERANCES, INTERFERENCE TO BRACKETS MAY OCCUR. INCREASE CUTOUT AREA TO ELIMINATE ANY INTERFERENCE WHICH MAY OCCUR.

NOTICE:

Installers and users must comply with all applicable federal, state and local laws regarding use and installation of warning devices.

Improper use or installation may void warranty coverage.

To review our Limited Warranty Statement & Return Policy for this or any SoundOff Signal product, visit our website at www.soundoffsignal.com/tech-services/returns/.

If you have questions regarding this product, contact **Technical Services**, Monday - Friday, 8 a.m. to 5 p.m. ET at **1.800.338.7337** (press #4).

Questions or comments that do not require immediate attention may be emailed to techservices@soundoffsignal.com.



nFORCE LED Interior Lightbar
 2015-2020 Tahoe / Suburban / Yukon / Yukon XL
 Full (1-Piece) Rear Facing

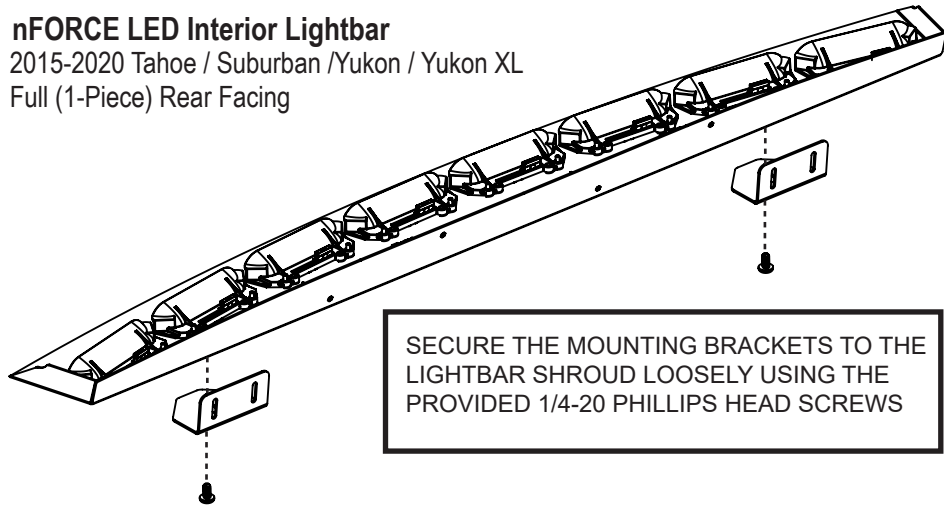

SECURE THE MOUNTING BRACKETS TO THE LIGHTBAR SHROUD LOOSELY USING THE PROVIDED 1/4-20 PHILLIPS HEAD SCREWS

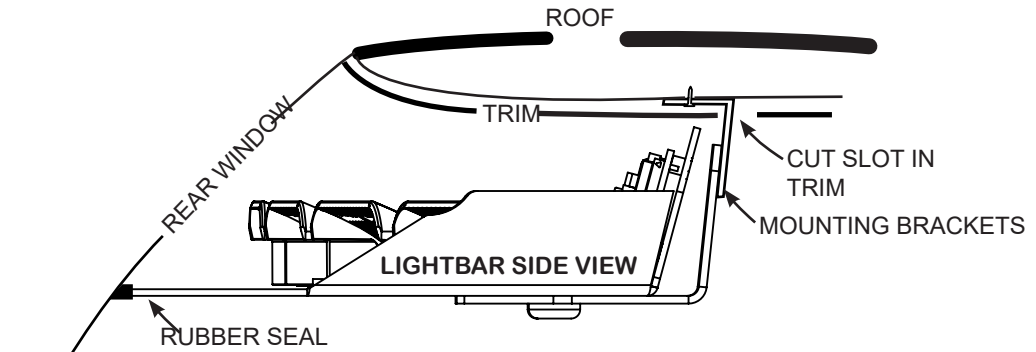

MOUNT THE LIGHTBAR TO THE MOUNTING BRACKETS THAT WERE INSTALLED ON STEP 2, 3.

ADJUST SHROUD SO IT IS LEVEL AND THE TRIM IS TOUCHING THE REAR WINDOW.

TIGHTEN ALL SCREWS TO SECURE IN PLACE

ROUTE WIRES TO SWITCHING EQUIPMENT. BE MINDFUL TO KEEP WIRE ROUTING AWAY FROM AIRBAG DEPLOYMENT ZONES.

OPERATION:

SEE 'ELECTRICAL INSTALLATION' SECTION OF THE NFORCE LED INTERIOR LIGHTBAR INSTALLATION PACKET.



1.800.338.7337 / www.soundoffsignal.com

NOTICE:

Installers and users must comply with all applicable federal, state and local laws regarding use and installation of warning devices.

Improper use or installation may void warranty coverage.

To review our Limited Warranty Statement & Return Policy for this or any SoundOff Signal product, visit our website at www.soundoffsignal.com/tech-services/returns/.

If you have questions regarding this product, contact **Technical Services**, Monday - Friday, 8 a.m. to 5 p.m. ET at 1.800.338.7337 (press #4).

Questions or comments that do not require immediate attention may be emailed to techservices@soundoffsignal.com.

ENHANCING SAFETY THROUGH INNOVATION