

**IMPORTANT NOTICE TO INSTALLER:** Make sure to read and understand all instructions and warnings before proceeding with the installation of this product. Ensure that the manual and any warning cards are delivered to the end user of this equipment. Proper installation of the lightbar requires the installer to have a thorough knowledge of automotive electronics, systems, and procedures. Lightbars provide an essential function of an effective visual warning system. The use of the lightbar does not insure that all drivers can or will abide by or react to an emergency warning signal, especially at high rates of speeds or long distances. The operator of the vehicle must never take the right of way for granted and it is the operator's responsibility to proceed safely. The effectiveness of the lightbar is highly dependant on the correct mounting and wiring. The installer must read and follow the manufacturer's installation instructions and warnings in the manual. The vehicle operator should verify daily that the lightbar is securely fastened to the vehicle and properly functioning before operating vehicle. The lightbar is intended for use by authorized personnel only. It is the user's responsibility to ensure they understand and operate the emergency warning devices in compliance with the applicable city, state and federal laws and regulations. SoundOff Signal assumes no liability for any loss resulting from the use of this warning device.

**Components/Contents**

Standard Equipment:

- 1 - nForce® LED Lightbar built to your specifications
- 1 - Breakout Box
- 1 - 24 Pin Harness

Other Parts that may be included depending on your configuration:

- 1 - Vehicle Specific Hook Kit w/ Hardware\*
- 2 - Fixed Height Mounting Brackets w/ Hardware or
- 1 - Flat Mount Hardware Kit or
- 2 - Headache Brackets w/ Hardware

\*Kits will vary with each lightbar depending on vehicle specified on order form.

**Unpack Lightbar**

1. Remove the lightbar from box and packaging.
2. Save packaging for later shipping.
3. Check components/contents.
4. Please reference these instructions for proper wiring and installation.

**Tools Required for Installation**

- 7/16" Socket with ratchet
- Phillips Head Screwdriver
- Drill bit #30



1.800.338.7337 / [www.soundoffsignal.com](http://www.soundoffsignal.com)

**NOTICE:**

Installers and users must comply with all applicable federal, state and local laws regarding use and installation of warning devices.

*Improper use or installation may void warranty coverage.*

To review our Limited Warranty Statement & Return Policy for this or any SoundOff Signal product, visit our website at [www.soundoffsignal.com/tech-services/returns/](http://www.soundoffsignal.com/tech-services/returns/).

If you have questions regarding this product, contact **Technical Services**, Monday - Friday, 8 a.m. to 5 p.m. ET at 1.800.338.7337 (press #4).

Questions or comments that do not require immediate attention may be emailed to [techservices@soundoffsignal.com](mailto:techservices@soundoffsignal.com).

**TABLE OF CONTENTS**

PAGE	CONTENT
1	COMPONENTS/ CONTENTS
2	MODULE SPECIFICATIONS
3	TECHNICAL/ POWER SPECIFICATIONS
4-5	FIXED HEIGHT BRACKETS AND HOOK MOUNTING
6	GASKET MOUNTING INSTRUCTIONS
7-13	ELECTRICAL INSTALLATION
14,15	PHOTO SENSOR
16	CONTROL HARNESS
17	LIGHT MODULE WIRE HARNESS LOCATIONS
18,19	DRIVER MODULE REPLACEMENT
20	NFORCE TROUBLESHOOTING
21	CONNECTION OF BREAKOUT BOX TO SOUNDOFF SIGNAL SIRENS
22	QUICK CONNECT HARNESS
23	REPLACEMENT PARTS
24	WARRANTY AND RETURN GOODS PROCEDURE

**Important Information:** \_\_\_\_\_

- To view the full Software Revision History click the  in the upper right hand corner of the nFORCE Lightbar Software application.
- Warning devices are strictly regulated and governed by Federal, State and Municipal ordinances. These devices shall be used ONLY on approved vehicles. It is the sole responsibility of the user of these devices to ensure compliance.
- DO NOT install this product or route any wires in the Air Bag Deployment Zone. Refer to your vehicle Owner's Manual for the location of any air bag deployment zones.
- DO NOT connect this device to a strobe power supply. This product is self-contained and does not require an external power supply.

 **WARNING**

This product contains high intensity LED devices. To prevent eye damage, DO NOT stare into the light beam at close range.

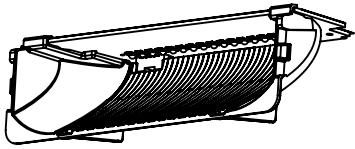
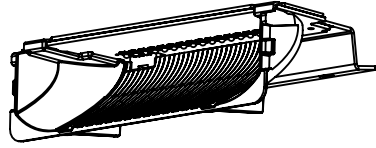
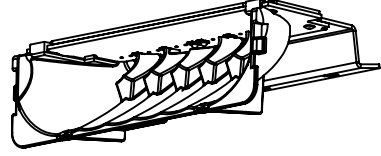
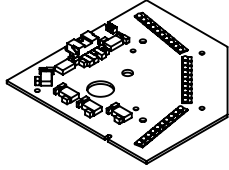
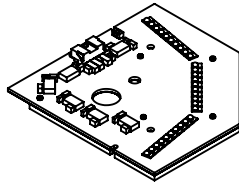
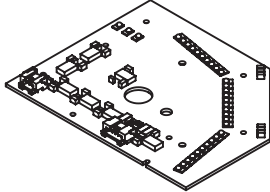
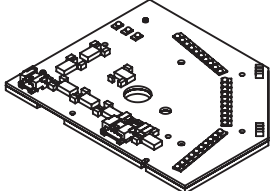
	<p><b>6 LED Single, Dual &amp; Tri Color Inboard Module</b></p> <p>INPUT VOLTAGE RANGE: 10-16Vdc  CURRENT DRAW: 0.5 Amps @ 12.8 Vdc (Flashing)  1.0 Amps @ 12.8 Vdc (Steady On)  WATTAGE: 6.4W (Flashing)</p>
	<p><b>9 LED Single Color Inboard Module</b></p> <p>INPUT VOLTAGE RANGE: 10-16Vdc  CURRENT DRAW: 0.75 Amps @ 12.8 Vdc (Flashing)  1.5 Amps @ 12.8 Vdc (Steady On)  WATTAGE: 9.6W (Flashing)</p>
	<p><b>6 LED Single Color Takedown Module</b></p> <p>INPUT VOLTAGE RANGE: 10-16Vdc  CURRENT DRAW: 1 Amps @ 12.8 Vdc (Steady On)  WATTAGE: 12.8 (Steady On)</p>
	<p><b>12 LED Single, Dual &amp; Tri Color Corner Module</b></p> <p>INPUT VOLTAGE RANGE: 10-16Vdc  CURRENT DRAW: 1 Amps @ 12.8 Vdc (Flashing)  2 Amps @ 12.8 Vdc (Steady On)  WATTAGE: 12.8W (Flashing)</p>
	<p><b>12 LED Single, Dual &amp; Tri Color Corner Module w/Alley</b></p> <p>INPUT VOLTAGE RANGE: 10-16Vdc  CURRENT DRAW: 1 Amps @ 12.8 Vdc (Flashing)  2.5 Amps @ 12.8 Vdc (Steady On)  WATTAGE: 12.8 (Flashing)</p>
	<p><b>18 LED Single Corner Module</b></p> <p>INPUT VOLTAGE RANGE: 10-16Vdc  CURRENT DRAW: 1.5 Amps @ 12.8 Vdc (Flashing)  3 Amps @ 12.8 Vdc (Steady On)  WATTAGE: 19.2W (Flashing)</p>
	<p><b>18 LED Single Corner w/Alley</b></p> <p>INPUT VOLTAGE RANGE: 10-16Vdc  WARNING CURRENT DRAW: 1.5 Amps @ 12.8 Vdc (Flashing)  3.5 Amps @ 12.8 Vdc (Steady On)  WARNING WATTAGE: 19.2W (Flashing)  ALLEY CURRENT DRAW: .25 Amps @ 12.8 Vdc (Flashing)  .5 Amps @ 12.8 Vdc (Steady On)  ALLEY WATTAGE: 6.4W (Steady On)</p>

FLASHING = AVERAGE  
STEADY ON (100%) = PEAK

**TOP VIEW WITH COVERS ON**

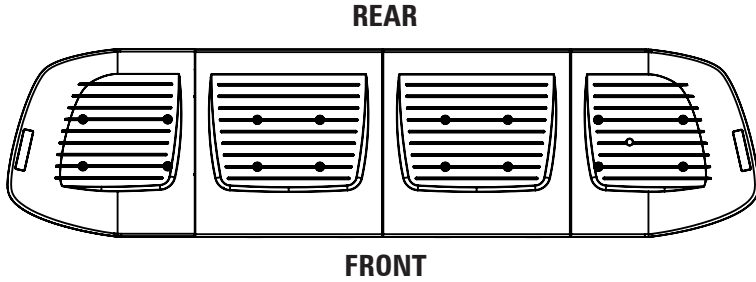

**TOP VIEW WITH COVERS OFF**

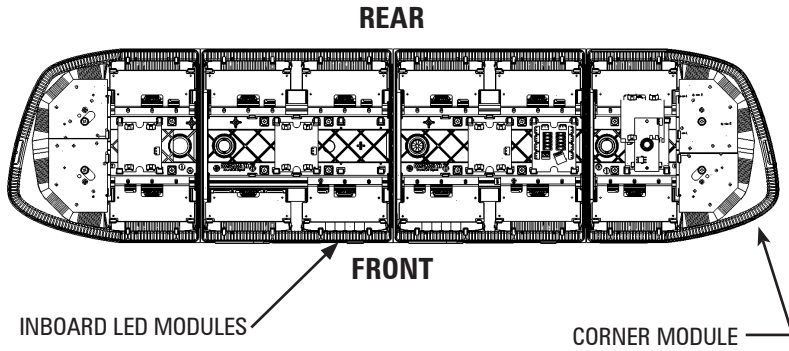

**BOTTOM VIEW**

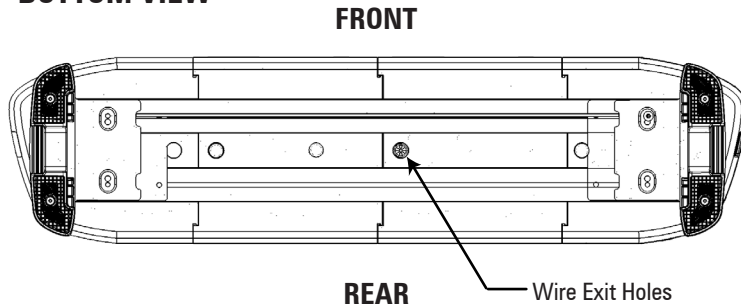

**TECHNICAL SPECIFICATIONS**

Material:	Aluminum Base, polycarbonate outer lenses, ASA/PC top cover.	
Roof Attachments:	1/4" bolt Stainless A2	
Operating Temperature:	-40° to +65° C	
LENGTH	# OF INBOARDS	DIMENSIONS
24"	2	12"D x 2.5"H inboard
36"	4	
42"	5	
48"	6	
54"	7	
60"	8	
72"	10	

**POWER SPECIFICATIONS**

Input Voltage Range:	10 -16 Vdc			
Light Bar Component	Current Draw (Average = Flashing)		Power Consumption (Watts)	
	Ignition ON	Ignition OFF	Ignition ON	Ignition OFF
Standby Current	0.010 Amps	0.002 Amps	0.13 Watts	0.03 Watts
Reverse Polarity	Protected			
Load Dump	Protected			
Wiring	Power Cable 15ft 14 AWG Wires, (+) Red, (-) Black Data Cable 25ft RJ-45 Type			

**NOTICE:**

Installers and users must comply with all applicable federal, state and local laws regarding use and installation of warning devices.

*Improper use or installation may void warranty coverage.*

To review our Limited Warranty Statement & Return Policy for this or any SoundOff Signal product, visit our website at [www.soundoffsignal.com/tech-services/returns/](http://www.soundoffsignal.com/tech-services/returns/).

If you have questions regarding this product, contact **Technical Services**, Monday - Friday, 8 a.m. to 5 p.m. ET at 1.800.338.7337 (press #4).

Questions or comments that do not require immediate attention may be emailed to [techservices@soundoffsignal.com](mailto:techservices@soundoffsignal.com).

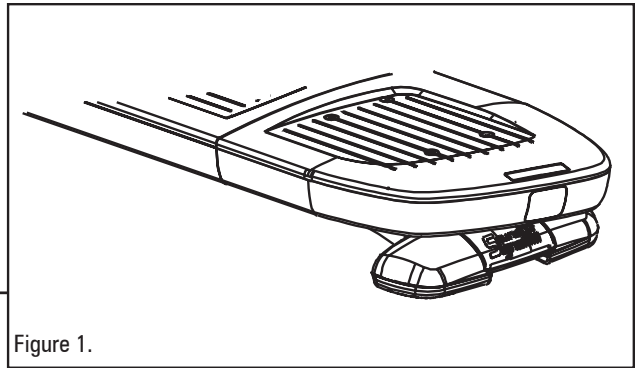

Figure 1.

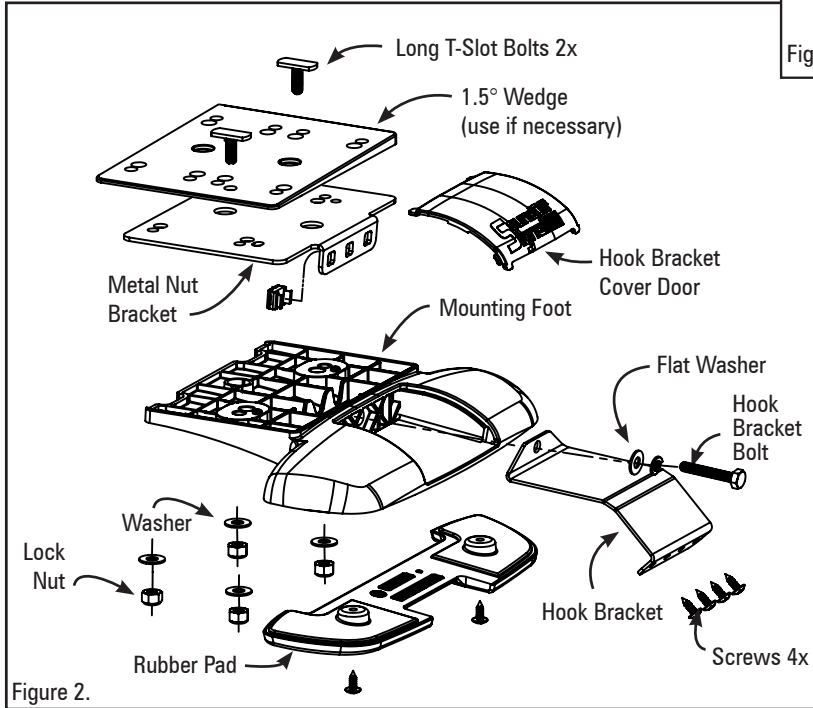

Figure 2.

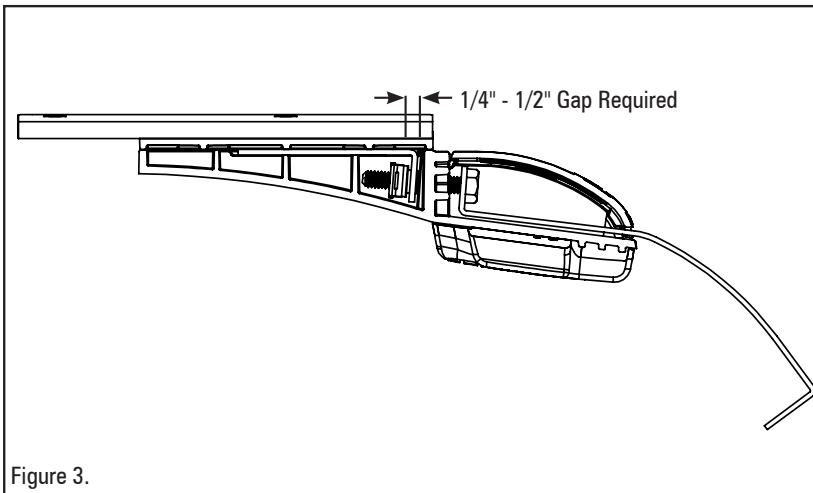

Figure 3.

### FIXED HEIGHT BRACKETS AND HOOK MOUNTING (NON-PURSUIT)

1. Keeping the lightbar level with the road, attach Mounting Feet to the roof of the vehicle using the 2 supplied T-Slot bolts. If the lightbar needs to be leveled, a 1.5° wedge has been provided. Non-pursuit pictured.
2. Place lightbar centered on the roof, and hold brackets up to the lightbar. A 1/4" to 1/2" gap should be between the hook bracket and front wall of the mounting foot prior to putting any tension on the hook bracket bolt (See Figure 3). Adjust the mounting foot position to accommodate for this gap.
3. Tighten 2 lock nuts to secure mounting foot to lightbar with max torque between 80-90in/lbs. **DO NOT OVERTIGHTEN!**
4. Using holes in the hook bracket as a template, drill 4 holes in the roof using the appropriate size drill. Secure hook bracket to roof with 4 screws on each side. Tighten hook bracket bolts with max torque 40-50in/lbs.
5. Tighten the 2 hook bracket bolts, torque details below:

Due to different vehicle construction and mounting locations, the torque levels for connecting hooks to the lightbar foot may be different based on the vehicle.

- A. Minimum requirement for torque should be 10 IN/LB, with a maximum level of 45 IN/LB.\*
- B. When installing the bolts connecting the hook to the lightbar foot, monitor both the lightbar and roof of the vehicle.
- C. Tighten to ensure there is no movement of the lightbar or foot by ensuring there is no movement either side to side, or front to rear after the torque has been done.

The lightbar must be securely mounted to the vehicle for safe operation.

\*Deflection of the lightbar and/or the roof of the vehicle may occur when torquing the bolts connecting the hook to the lightbar foot. Any deflection should be kept at a minimum to avoid damage to the lightbar or vehicle.

**NOTE: As always, it is recommended to check the integrity of mounted lightbars on a daily basis to ensure secure attachment to the vehicle for continued safe operation.**

6. Install the cover door over the hook bracket bolt to finish the assembly. Place tab of one side into place and then push the second tab into place with a flat-head screw driver.

### **⚠ WARNING**

Route wires only in locations that are not subjected to potential wear. Make sure to avoid routing wires in the deployment area of your air bag. Refer to your vehicle's owner's manual for airbag deployment zone.

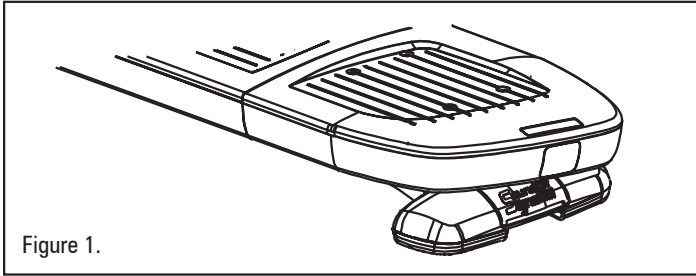

Figure 1.

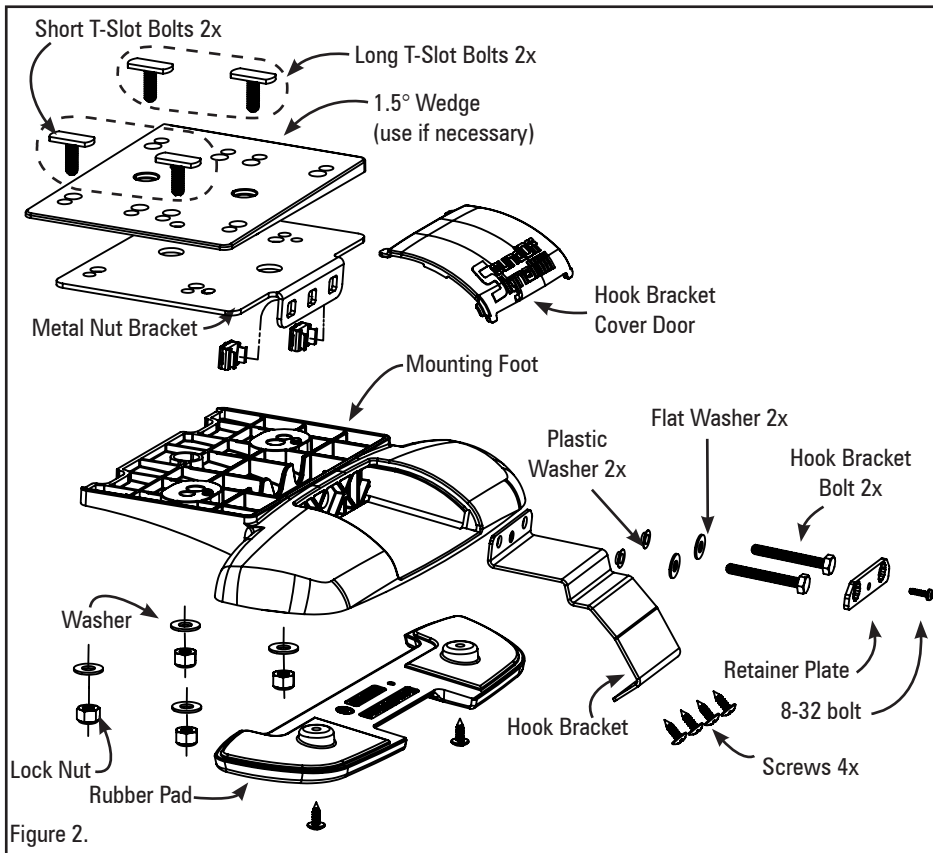

Figure 2.

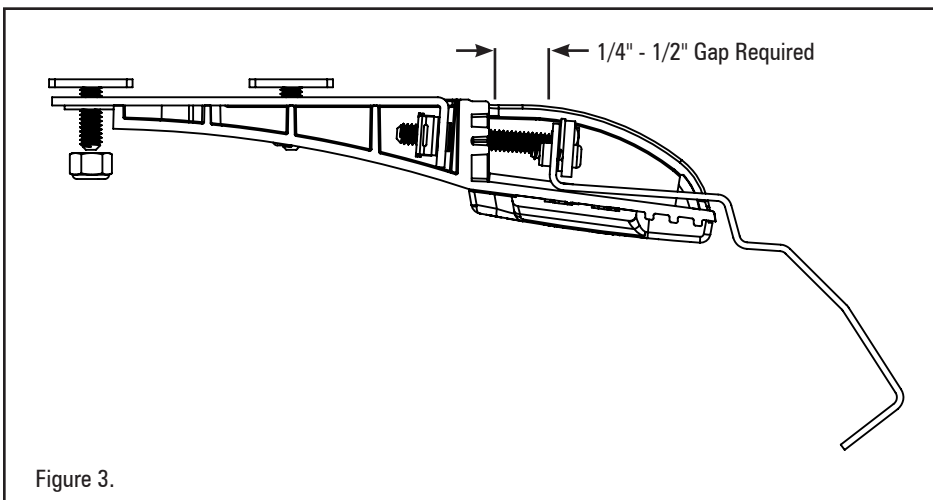

Figure 3.

## FIXED HEIGHT BRACKETS AND HOOK MOUNTING (PURSUIT)

1. Attach the supplied screws to the mounting foot to secure the rubber pad as shown in Figure 3 (on next page.)

2. Insert the 2 plastic washers inside holes of the provided hook brackets.

3. Keeping the lightbar level to the road, attach mounting feet to the roof of the vehicle using the 4 supplied T-Slot bolts.

4. Place lightbar centered on the roof, and hold brackets up to the lightbar. A 1/4" to 1/2" gap should be between the hook bracket and front wall of the mounting foot prior to putting any tension on the hook bracket bolt (See Figure 4). Adjust the mounting foot position to accommodate for this gap.

5. Tighten 4 lock nuts to secure mounting foot to lightbar with max torque between 80-90in/lbs. **DO NOT OVERTIGHTEN!**

6. Using the holes in the hook bracket as a template, drill 4 holes in the roof using the appropriate size drill. Secure hook bracket to roof with 4 screws on each side.

7. Tighten the hook bracket bolts, torque details below:

Due to different vehicle construction and mounting locations, the torque levels for connecting hooks to the lightbar foot may be different based on the vehicle.

A. Minimum requirement for torque should be 10 IN/LB, with a maximum level of 45 IN/LB.\*

B. When installing the bolts connecting the hook to the lightbar foot, monitor both the lightbar and roof of the vehicle.

C. Tighten to ensure there is no movement of the lightbar or foot by ensuring there is no movement either side to side, or front to rear after the torque has been done.

The lightbar must be securely mounted to the vehicle for safe operation.

\*Deflection of the lightbar and/or the roof of the vehicle may occur when torquing the bolts connecting the hook to the lightbar foot. Any deflection should be kept at a minimum to avoid damage to the lightbar or vehicle.

**NOTE: As always, it is recommended to check the integrity of mounted lightbars on a daily basis to ensure secure attachment to the vehicle for continued safe operation.**

8. Insert the retainer plates over the 2 bolts on each of the hook kit brackets. Screw in the retainer plate to the hook kit bracket using the 8-32 bolts.

9. Install the cover door over the hook bracket bolt to finish the assembly. Place tab of one side into place and then push the second tab into place with a flathead screw driver.

### **⚠ WARNING**

Route wires only in locations that are not subjected to potential wear. Make sure to avoid routing wires in the deployment area of your air bag. Refer to your vehicle's owner's manual for airbag deployment zone.

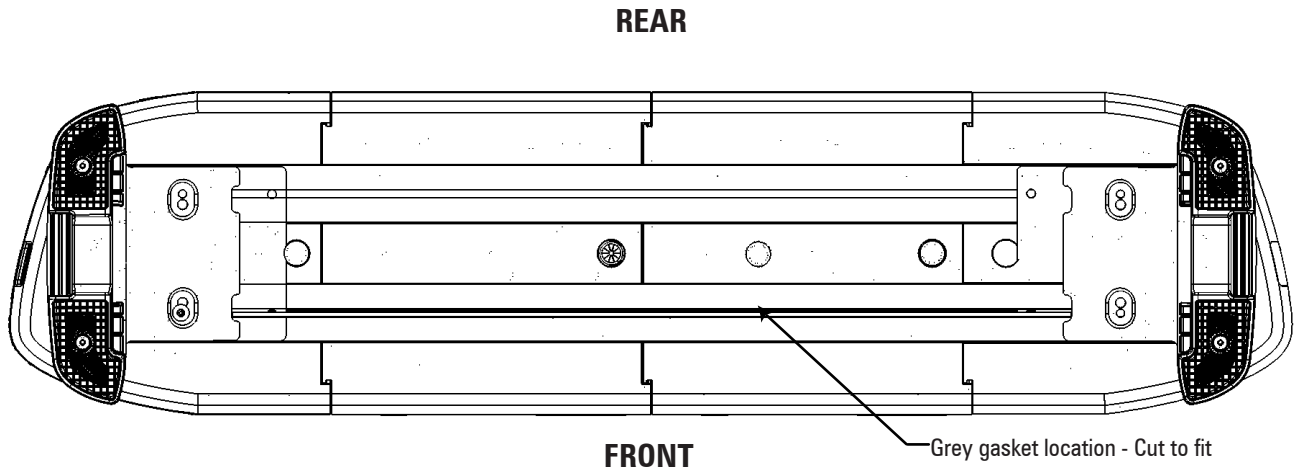

### **GASKET MOUNTING INSTRUCTIONS**

Install the Grey gasket in the front slot of the lightbar as shown above

**NOTICE:**

Installers and users must comply with all applicable federal, state and local laws regarding use and installation of warning devices.

*Improper use or installation may void warranty coverage.*

To review our Limited Warranty Statement & Return Policy for this or any SoundOff Signal product, visit our website at [www.soundoffsignal.com/tech-services/returns/](http://www.soundoffsignal.com/tech-services/returns/).

If you have questions regarding this product, contact **Technical Services**, Monday - Friday, 8 a.m. to 5 p.m. ET at **1.800.338.7337** (press #4).

Questions or comments that do not require immediate attention may be emailed to [techservices@soundoffsignal.com](mailto:techservices@soundoffsignal.com).



nFORCE® LED Lightbar

## ELECTRICAL INSTALLATION

### Featured Highlights & Terminology:

**Mode Select:** The nForce Lightbar is equipped with 2 selectable pattern configuration modes via the Mode Select Input. Default is Mode 1 where the input is floating, Mode 2 is in use when the input activated. This feature allows 2 complete sets of patterns to be programmed into the Lightbar's non-volatile memory. Once programming configuration is complete, the Mode can be changed "on-the-fly" by an activation switch which applies voltage to the Mode 2 input wire.

**Cruise Mode:** Allows the user to program any light group(s) to "Glow" when this feature is activated. For dual / tri color bars, the color for each light group is selectable.

**Directional Arrow Built-in:** The directional controller is built-in w/ 6 arrow patterns for each of the 3 modes (left arrow, right arrow, and center out arrow) and the color is selectable for dual / tri color bars

**Scene Light Mode:** Allows the user to program any Light Head Group(s) to turn on steady when this feature is activated to provide additional scene lighting. **The activation of this input also activates the Takedown function**

**Stop / Tail / Turn Mode:** Allows the user to program any Light Head Group(s) to turn operate in 2 levels of intensity for tail and stop/turn functions.

**Low Power Mode:** Operates lighting at reduced intensity.

### **⚠ WARNING**

**ALL CUSTOMER SUPPLIED POWER WIRES CONNECTING TO THE POSITIVE (+) OR NEGATIVE (-) BATTERY TERMINAL OR LOCAL CHASSIS GROUND (-) MUST BE SIZED TO SUPPLY AT LEAST 125% OF THE MAXIMUM CURRENT AND PROPERLY FUSED AT THE POWER SOURCE WITH APPROPRIATELY RATED FUSE.**

#### Power Cable:

1. Route lightbar power cables as close to vehicles power source (battery) as possible.
2. Install a maximum of 30Amp Fuse (customer supplied) to the end of the RED wire of the Lightbar Power Cable.
  - a. Remove the fuse before connecting any wires to the battery.
  - b. DO NOT USE CIRCUIT BREAKER OR FUSIBLE LINK.
3. Connect the other end of the Fuse to the POSITIVE (+) terminal of the battery.
  - a. Do NOT use any more than 2ft of wire between the battery terminal and the fuse and ensure the wire is protected and secured from being cut into; this is non-fused wire.
4. Connect the BLACK wire to the factory chassis ground right next to the battery.

#### Control (Data) Cable:

1. Route Lightbar Control Cable to the location where all controlling equipment will be, i.e. switch box, center console area.
2. Locate the Breakout Box in the same area to connect jumpers from the switching equipment to the breakout box.
3. Refer to breakout box hookup table on page 9.

**NOTE: Breakout Box must be mounted inside vehicle where it will not get wet.**

#### Initial Power up Test:

1. Plug RJ-45 power / data plug into 'Lightbar' connector on the breakout box.
2. **Apply power to pink/white ignition wire on breakout box. See table 1 on page 9.**
3. Observe the GREEN Data Link indicator LED on the Breakout Box; the Green LED will be ON showing power is connected.
4. The Red indicator LED on the breakout box will be steady ON whenever any of the input wires are active or data is received from a siren.

#### Low Power (Standby) Mode (reduced standby current)

If there is no input to the breakout box the lightbar will go into a "standby" mode. The standby mode is a low power mode that is used to extend the life of your battery. The lightbar will awaken from the standby mode if any input is activated on the breakout box.

## ELECTRICAL INSTALLATION (CONT.)

### Warning Flash Pattern Configuration:

- a. Apply voltage to Ignition Input Wire and then set Switch #2 on Breakout box to down position (Switch #1 must be in Up position)
- b. Apply voltage to the activation wire of the function which requires pattern to be changed (i.e. Front Corner, Takedown, Left Alley, etc.)
- c. Apply voltage to the Mode activation wire to configure mode 2 flash patterns, leave Mode activation wire floating to configure mode 1 flash patterns
- d. Momentarily apply voltage to the pattern select wire to change the warning flash pattern
- e. Set Switch #2 on Breakout box to up position to save settings and return light-bar to normal operating mode

**NOTE:** Takedown and Alley light patterns are limited to pattern #1 – 22

\*fpm=Flashes per Minute

\*\*fps=Flashes per Second

### FLASH PATTERNS

#	Name	SAE Compliant Timing	ECE Compliant Timing	California Title 13 Compliant Timing	Color	Sequence	fpm	fps
SC1	Random 1	Yes	No	No	#1	Variable	-	-
SN2	Random 2	No	No	No	#1	Variable	-	-
SC3	Quint	Yes	No	No	#1	Alternating	70	1.2
SC4	Quad 2	Yes	No	No	#1	Variable	-	-
SC5	Q-Switch	Yes	No	No	#1	Variable	-	-
SC6	Double	Yes	No	No	#1	Alternating	115	1.9
SC7	Power Pulse	Yes	No	No	#1	Alternating	180	3
SC8	Road Runner	Yes	No	Yes	#1	Alternating	115	1.9
SC9	Slow Runner	Yes	No	Yes	#1	Alternating	70	1.2
SN10	Warp	No	No	No	#1	Alternating	350	5.8
SN11	Inter-Cycle	No	No	No	#1	Alternating	-	-
SN12	Warp 1-2-3	No	No	No	#1	Alternating	-	-
SC13	E-Single	Yes	Yes	No	#1	Alternating	125	2.1
SC14	E-Double	Yes	Yes	No	#1	Alternating	125	2.1
SC15	E-Triple	Yes	Yes	No	#1	Alternating	125	2.1
SC16	E-Single Sim	Yes	Yes	No	#1	Simultaneous	125	2.1
SC17	E-Double Sim	Yes	Yes	No	#1	Simultaneous	125	2.1
SN18	Super Slow Runner	No	No	No	#1	Alternating	55	0.9
SC19	Quint Simultaneous	Yes	No	No	#1	Simultaneous	70	1.2
SC20	Road Runner Simultaneous	Yes	No	No	#1	Simultaneous	114	1.9
SC21	Quint Pass/Steady Driver	Yes	No	No	#1	-	70	1.2
SC22	Road Runner Pass/Steady Driver	Yes	No	No	#1	-	114	1.9
SC23	Quint 2	Yes	No	No	#1	-	70	1.2
SN24	Warp 2	No	No	No	#1	-	350	5.8
SN25	Inter-Cycle 2	No	No	No	#1	-	-	-
SN26	Flicker Brake	No	No	No	#1	-	-	-
SN27	Flicker Cruise	No	No	No	#1	-	-	-
SN28	Steady	No	No	No	#1	-	-	-
SN29	Manifesto	No	No	No	#1	-	-	-
SN30	Power Evert	No	No	No	#1	-	-	-
SN31	Dazzle	No	No	No	#1	-	-	-
SN32	Quiver	No	No	No	#1	-	-	-

#### **NOTICE:**

Installers and users must comply with all applicable federal, state and local laws regarding use and installation of warning devices.

*Improper use or installation may void warranty coverage.*

*To review our Limited Warranty Statement & Return Policy for this or any SoundOff Signal product, visit our website at [www.soundoffsignal.com/tech-services/returns/](http://www.soundoffsignal.com/tech-services/returns/).*

*If you have questions regarding this product, contact **Technical Services**, Monday - Friday, 8 a.m. to 5 p.m. ET at **1.800.338.7337** (press #4).*

*Questions or comments that do not require immediate attention may be emailed to [techservices@soundoffsignal.com](mailto:techservices@soundoffsignal.com).*



## FLASH PATTERNS (CONT.)

#	Name	SAE Compliant Timing	ECE Compliant Timing	California Title 13 Compliant Timing	Color	Sequence	fpm	fps
SN33	Power Sway	No	No	No	#1	-	-	-
SN34	Evert	No	No	No	#1	-	-	-
SN35	Alternating Rapid Flash	No	No	No	#1	-	-	-
SN36	Swift Impact	No	No	No	#1	-	-	-
SN37	Tango	No	No	No	#1	-	-	-
SN38	Tremble	No	No	No	#1	-	-	-
SN39	Shake	No	No	No	#1	-	-	-
SN40	Evolver	No	No	No	#1	Simultaneous	-	-
SN41	Corner Sweep	No	No	No	#1	-	-	-
SN42	Corner Sweep Slow	No	No	No	#1	-	-	-
SN43	Full/Sweep	No	No	No	#1	-	-	-
SN44	Full/Sweep Slow	No	No	No	#1	-	-	-
SN45	Center Sweep	No	No	No	#1	-	-	-
SN46	Center Sweep Slow	No	No	No	#1	-	-	-
SN47	Orbit	No	No	No	#1	-	-	-
SN48	Orbit Slow	No	No	No	#1	-	-	-
SN49	Double Orbit	No	No	No	#1	-	-	-
SN50	Slow Double Orbit	No	No	No	#1	-	-	-
SN51	Retrograde Orbit	No	No	No	#1	-	-	-
SN52	Slow Retrograde Orbit	No	No	No	#1	-	-	-
SN53	Progressive Alternate	No	No	No	#1	-	-	-
SN54	Recurrent	No	No	No	#1	Simultaneous	-	-
DC1	Random Dual #1	Yes	No	No	#1/2	Variable	-	-
DN2	Random Dual #2	No	No	No	#1/2	Variable	-	-
DC3	Quint Dual	Yes	No	No	#1/2	Alternating	70	1.2
DC4	Quad 2 Dual	Yes	No	No	#1/2	Variable	-	-
DC5	Q-Switch Dual	Yes	No	No	#1/2	Variable	-	-
DC6	Double Dual	Yes	No	No	#1/2	Alternating	115	1.9
DC7	Power Pulse Dual	Yes	No	No	#1/2	Alternating	180	3
DC8	Road Runner Dual	Yes	No	Yes	#1/2	Alternating	115	1.9
DC9	Slow Runner Dual	Yes	No	Yes	#1/2	Alternating	70	1.2
DN10	Warp Dual	No	No	No	#1/2	Alternating	350	5.8
DN11	Inter-Cycle Dual	No	No	No	#1/2	Alternating	-	-
DN12	Warp 1-2-3 Dual	No	No	No	#1/2	Alternating	-	-
DN13	Pattern #1 Dual	No	No	No	#1/2	Variable	-	-
DN14	Pattern #2 Dual	No	No	No	#1/2	Variable	-	-
DN15	Impact Dual	No	No	No	#1/2	Variable	-	-
DN16	Explosion Dual	No	No	No	#1/2	Variable	-	-
DC17	Quint Simultaneous Dual	Yes	No	No	#1/2	Simultaneous	70	1.2

**NOTICE:**

Installers and users must comply with all applicable federal, state and local laws regarding use and installation of warning devices.

*Improper use or installation may void warranty coverage.*

*To review our Limited Warranty Statement & Return Policy for this or any SoundOff Signal product, visit our website at [www.soundoffsignal.com/tech-services/returns/](http://www.soundoffsignal.com/tech-services/returns/).*

*If you have questions regarding this product, contact **Technical Services**, Monday - Friday, 8 a.m. to 5 p.m. ET at 1.800.338.7337 (press #4).*

*Questions or comments that do not require immediate attention may be emailed to [techservices@soundoffsignal.com](mailto:techservices@soundoffsignal.com).*

## FLASH PATTERNS (CONT.)

#	Name	SAE Compliant Timing	ECE Compliant Timing	California Title 13 Compliant Timing	Color	Sequence	fpm	fps
DC18	Road Runner Sim. Dual	Yes	No	No	#1/2	Simultaneous	114	1.9
DC19	Quint 2 Dual	Yes	No	No	#1/2	-	70	1.2
DN20	Warp 2 Dual	No	No	No	#1/2	-	350	5.8
DN21	Inter-Cycle 2 Dual	No	No	No	#1/2	-	-	-
DN22	Super Slow Runner Dual	No	No	No	#1/2	-	-	-
DN23	Flicker Cruise Dual	No	No	No	#1/2	-	-	-
DN24	Manifesto Dual	No	No	No	#1/2	-	-	-
DN25	Power Evert Dual	No	No	No	#1/2	-	-	-
DN26	Dazzle Dual	No	No	No	#1/2	-	-	-
DN27	Quiver Dual	No	No	No	#1/2	-	-	-
DN28	Power Sway Dual	No	No	No	#1/2	-	-	-
DN29	Evert Dual	No	No	No	#1/2	-	-	-
DN30	Alternating Rapid Flash Dual	No	No	No	#1/2	-	-	-
DN31	Swift Impact Dual	No	No	No	#1/2	-	-	-
DN32	Tango Dual	No	No	No	#1/2	-	-	-
DN33	Tremble Dual	No	No	No	#1/2	-	-	-
DN34	Shake Dual	No	No	No	#1/2	-	-	-
DN35	Evolver Dual	No	No	No	#1/2	Simultaneous	-	-
DN36	Corner Sweep Dual	No	No	No	#1/2	-	-	-
DN37	Corner Sweep Slow Dual	No	No	No	#1/2	-	-	-
DN38	Full/Sweep Dual	No	No	No	#1/2	-	-	-
DN39	Full/Sweep Slow Dual	No	No	No	#1/2	-	-	-
DN40	Center Sweep Dual	No	No	No	#1/2	-	-	-
DN41	Center Sweep Slow Dual	No	No	No	#1/2	-	-	-
DN42	Orbit Dual	No	No	No	#1/2	-	-	-
DN43	Orbit Slow Dual	No	No	No	#1/2	-	-	-
DN44	Double Orbit Dual	No	No	No	#1/2	-	-	-
DN45	Slow Double Orbit Dual	No	No	No	#1/2	-	-	-
DN46	Retrograde Orbit Dual	No	No	No	#1/2	-	-	-
DN47	Slow Retrograde Orbit Dual	No	No	No	#1/2	-	-	-
DN48	Progressive Alternate Dual	No	No	No	#1/2	-	-	-
DN49	Recurrent Dual		No	No	#1/2	Simultaneous	-	-
TN1	Pattern 1 Tri	No	No	No	#1/2/3	Alternating	-	-
TN2	Random Tri	No	No	No	#1/2/3	Alternating	-	-
TC3	Quint Tri	Yes	No	No	#1/2/3	Alternating	70	1.2
TC4	Quad 2 Tri	Yes	No	No	#1/2/3	Alternating	-	-
TN5	Pattern 2 Tri	No	No	No	#1/2/3	-	-	-
TC6	Double Tri	Yes	No	No	#1/2/3	Alternating	115	1.9
TC7	Power Pulse Tri	Yes	No	No	#1/2/3	Alternating	180	3

**NOTICE:**

Installers and users must comply with all applicable federal, state and local laws regarding use and installation of warning devices.

*Improper use or installation may void warranty coverage.*

*To review our Limited Warranty Statement & Return Policy for this or any SoundOff Signal product, visit our website at [www.soundoffsignal.com/tech-services/returns/](http://www.soundoffsignal.com/tech-services/returns/).*

*If you have questions regarding this product, contact **Technical Services**, Monday - Friday, 8 a.m. to 5 p.m. ET at 1.800.338.7337 (press #4).*

*Questions or comments that do not require immediate attention may be emailed to [techservices@soundoffsignal.com](mailto:techservices@soundoffsignal.com).*

## FLASH PATTERNS (CONT.)

#	Name	SAE Compliant Timing	ECE Compliant Timing	California Title 13 Compliant Timing	Color	Sequence	fpm	fps
TC8	Road Runner Tri	Yes	No	Yes	#1/2/3	Alternating	115	1.9
TC9	Slow Runner Tri	Yes	No	Yes	#1/2/3	Alternating	70	1.2
TN10	Warp Tri	No	No	No	#1/2/3	Alternating	350	5.8
TN11	Inter-Cycle Tri	No	No	No	#1/2/3	Alternating	-	-
TN12	Warp 1-2-3 Tri	No	No	No	#1/2/3	Alternating	-	-
TN13	Super Slow Runner Tri	No	No	No	#1/2/3	Alternating	55	0.9
TC14	Quint Simultaneous Tri	Yes	No	No	#1/2/3	Simultaneous	70	1.2
TC15	Road Runner Sim. Tri	Yes	No	No	#1/2/3	Simultaneous	114	1.9
TC16	Quint 2 Tri	Yes	No	No	#1/2/3	Alternating	70	1.2
TN17	Warp 2 Tri	No	No	No	#1/2/3	Alternating	350	5.8
TN18	Inter-Cycle 2 Tri	No	No	No	#1/2/3	Alternating	-	-
TN19	Pattern 3 Tri	No	No	No	#1/2/3	-	-	-
TN20	Flicker Cruise Tri	No	No	No	#1/2/3	-	-	-
TN21	Manifesto Tri	No	No	No	#1/2/3	-	-	-
TN22	Power Evert Tri	No	No	No	#1/2/3	-	-	-
TN23	Dazzle Tri	No	No	No	#1/2/3	-	-	-
TN24	Quiver Tri	No	No	No	#1/2/3	-	-	-
TN25	Power Sway Tri	No	No	No	#1/2/3	-	-	-
TN26	Evert Tri	No	No	No	#1/2/3	-	-	-
TN27	Alternating Rapid Flash Tri	No	No	No	#1/2/3	-	-	-
TN28	Swift Impact Tri	No	No	No	#1/2/3	-	-	-
TN29	Tango Tri	No	No	No	#1/2/3	-	-	-
TN30	Tremble Tri	No	No	No	#1/2/3	-	-	-
TN31	Shake Tri	No	No	No	#1/2/3	-	-	-
TN32	Evolver Tri	No	No	No	#1/2/3	Simultaneous	-	-
TN33	Corner Sweep Tri	No	No	No	#1/2/3	-	-	-
TN34	Corner Sweep Slow Tri	No	No	No	#1/2/3	-	-	-
TN35	Full/Sweep Tri	No	No	No	#1/2/3	-	-	-
TN36	Full/Sweep Slow Tri	No	No	No	#1/2/3	-	-	-
TN37	Center Sweep Tri	No	No	No	#1/2/3	-	-	-
TN38	Center Sweep Slow Tri	No	No	No	#1/2/3	-	-	-
TN39	Orbit Tri	No	No	No	#1/2/3	-	-	-
TN40	Orbit Slow Tri	No	No	No	#1/2/3	-	-	-
TN41	Double Orbit Tri	No	No	No	#1/2/3	-	-	-
TN42	Double Orbit Slow Tri	No	No	No	#1/2/3	-	-	-
TN43	Retrograde Orbit Tri	No	No	No	#1/2/3	-	-	-
TN44	Retrograde Orbit Slow Tri	No	No	No	#1/2/3	-	-	-
TN45	Progressive Alternate Tri	No	No	No	#1/2/3	-	-	-
TN46	Recurrent Tri	No	No	No	#1/2/3	Simultaneous	-	-

**NOTICE:**

Installers and users must comply with all applicable federal, state and local laws regarding use and installation of warning devices.

*Improper use or installation may void warranty coverage.*

*To review our Limited Warranty Statement & Return Policy for this or any SoundOff Signal product, visit our website at [www.soundoffsignal.com/tech-services/returns/](http://www.soundoffsignal.com/tech-services/returns/).*

*If you have questions regarding this product, contact **Technical Services**, Monday - Friday, 8 a.m. to 5 p.m. ET at 1.800.338.7337 (press #4).*

*Questions or comments that do not require immediate attention may be emailed to [techservices@soundoffsignal.com](mailto:techservices@soundoffsignal.com).*

## ELECTRICAL INSTALLATION (CONT.)

### Arrow Flash Pattern Configuration:

- a. Apply voltage to Ignition Input Wire and then set Switch #2 on Breakout box to down position (Switch #1 must be in Up position)
- b. Apply voltage to the Left Arrow activation wire to set Left Arrow pattern, apply voltage to Right Arrow activation wire to set Right Arrow pattern, apply voltage to Left Arrow and Right Arrow activation wires to set Center out Arrow pattern
- c. Momentarily apply voltage to the pattern select wire to change the arrow flash pattern
- d. Set Switch #2 on Breakout box to up position to save settings and return light-bar to normal operating mode

### Arrow Color Configuration:

- a. Apply voltage to Ignition Input Wire and then set Switch #2 on Breakout box to down position (Switch #1 must be in Up position)
- b. Determine which module inputs are needed for Arrow function
- c. Apply voltage to the Left Arrow or Right Arrow activation wires
- d. Apply voltage to the light group wire(s) required (i.e. Rear Inboard 1, Rear Inboard 2, etc.)
- e. Momentarily apply voltage to the pattern select wire to change the color between Off, Color 1, Color 2, and Color 3.

**NOTE: If configuring a single color or dual color module, make sure the chosen color is configured for Off and not a color which does not exist on the module. The light-bar will flash color #1 of all modules configured for Arrow function. If a module flashes every 2 seconds and is not intended to be on when an Arrow function is activated, repeat steps 'd' and 'e' until module no longer flashes.**

- f. Set Switch #2 on Breakout box to up position to save settings and return light-bar to normal operating mode

### Takedown and Work-light Configuration:

- a. Apply voltage to Ignition Input Wire and then set Switch #2 on Breakout box to down (Switch #1 must be in Up position)
- b. Determine which module inputs are needed for Takedowns or Work-lights
- c. Apply voltage to the Takedown activation wire
- d. Apply voltage to the light group wire(s) required (i.e. Front Inboard 1, Rear Inboard 2, etc.)
- e. Momentarily apply voltage to the pattern select wire to change the color between Off, Color 1, Color 2, and Color 3.

**NOTE: If configuring a single color or dual color module, make sure the chosen color is configured for Off and not a color which does not exist on the module. The light-bar will flash color #1 of all modules configured for takedown. If a module flashes every 2 seconds and is not intended to be on when takedown is activated, repeat steps 'd' and 'e' until module no longer flashes.**

- f. Set Switch #2 on Breakout box to up position to save settings and return light-bar to normal operating mode

### Scene light Configuration:

- a. Apply voltage to Ignition Input Wire and then set Switch #2 on Breakout box to down (Switch #1 must be in Up position)
- b. Determine which module inputs are needed for Scene Lighting
- c. Apply voltage to the Scene light activation wire
- d. Apply voltage to the light group wire(s) required (i.e. Front Inboard 1, Rear Inboard 2, etc.)
- e. Momentarily apply voltage to the pattern select wire to change the color between Off, Color 1, Color 2, and Color 3.

**NOTE: If configuring a single color or dual color module, make sure the chosen color is configured for Off and not a color which does not exist on the module. The light bar will flash color #1 of all modules configured for scene light. If a module flashes every 2 seconds and is not intended to be on when scene light function is activated, repeat steps 'd' and 'e' until module no longer flashes.**

- f. Set Switch #2 on Breakout box to up position to save settings and return light-bar to normal operating mode

### ARROW PATTERNS

#	Name	SAE	ECE	California Title	Color	Sequence	fpm	fps
		Compliant Timing	Compliant Timing	13 Compliant Timing				
1	Single Fast	No	No	No	-	-	-	-
2	Single Slow	No	No	No	-	-	-	-
3	Chaser Fast	No	No	No	-	-	-	-
4	Chaser Slow	No	No	No	-	-	-	-
5	Fill Fast	No	No	No	-	-	-	-
6	Fill Slow	No	No	No	-	-	-	-
7	Grow/Shrink	No	No	No	-	-	-	-
8	Warning w/Arrow	No	No	No	-	-	-	-
9	Warning w/Arrow Fill	No	No	No	-	-	-	-
10	Arrow Random 1	No	No	No	-	-	-	-
11	Arrow Random 2	No	No	No	-	-	-	-

## ELECTRICAL INSTALLATION (CONT.)

### **Stop / Tail / Turn (STT) Light Configuration:**

- Apply voltage to Ignition Input Wire and then set Switch #2 on Breakout box to down position (Switch #1 must be in Up position)
- Determine which module inputs are needed for Stop / Tail / Turn Lights
- Apply voltage to the Left Turn or Right Turn activation wires
- Apply voltage to the light group wire(s) required (i.e. Rear Inboard 1, Rear Inboard 2, etc.)
- Momentarily apply voltage to the pattern select wire to change the color between Off, Color 1, Color 2, and Color 3.

**NOTE: If configuring a single color or dual color module, make sure the chosen color is configured for Off and not a color which does not exist on the module. The light-bar will flash color #1 of all modules configured for STT function. If a module flashes every 2 seconds and is not intended to be on when an STT function is activated, repeat steps 'd' and 'e' until module no longer flashes.**

- Set Switch #2 on Breakout box to up position to save settings and return light-bar to normal operating mode

### **Cruise Mode Configuration:**

- Apply voltage to Ignition Input Wire and then set Switch #2 on Breakout box to down position (Switch #1 must be in Up position)
- Determine which module inputs are needed for cruise mode
- Apply voltage to the Cruise Mode activation wire
- Apply voltage to the light group wire(s) required (i.e. Front Corner, Front Inboard 1, etc.)
- Momentarily apply voltage to the pattern select wire to change the color between Off, Color 1, Color 2, and Color 3.

**NOTE: If configuring a single color or dual color module, make sure the chosen color is configured for Off and not a color which does not exist on the module. The lightbar will flash color #1 of all modules configured for cruise mode. If a module flashes every 2 seconds and is not intended to be on when Cruise mode is activated, repeat steps 'd' and 'e' until module no longer flashes.**

- Set Switch #2 on Breakout box to up position to save settings and return light-bar to normal operating mode

### **IMPORTANT**

**WHEN PASSING CABLES THROUGH FIREWALL OR OTHER SHEETMETAL, INSERT GROMMET TO PROTECT THE CABLE!**

### **⚠ WARNING**

**Route wires only in locations that are not subjected to potential wear. Make sure to avoid routing wires in the deployment area of your air bag. Refer to your vehicle's owner's manual for airbag deployment zone.**

### **NOTICE:**

Installers and users must comply with all applicable federal, state and local laws regarding use and installation of warning devices.

*Improper use or installation may void warranty coverage.*

To review our Limited Warranty Statement & Return Policy for this or any SoundOff Signal product, visit our website at [www.soundoffsignal.com/tech-services/returns/](http://www.soundoffsignal.com/tech-services/returns/).

If you have questions regarding this product, contact **Technical Services**, Monday - Friday, 8 a.m. to 5 p.m. ET at 1.800.338.7337 (press #4).

Questions or comments that do not require immediate attention may be emailed to [techservices@soundoffsignal.com](mailto:techservices@soundoffsignal.com).

## PHOTO SENSOR (if equipped)

The photo sensor continuously monitors ambient light conditions and will control functions configured for operation with the photo sensor input. By default, the photo sensor will (SET) all light modules into low power mode when dark ambient light levels below 50 lux are detected for more than 5 seconds. When ambient light levels exceed 300 lux for 5 seconds, the low power mode will (CLEAR) turn off and the lightbar will revert back to full intensity.

The photo sensor is subject to ambient light conditions of the specific environment for the vehicle and needs to be thoroughly tested by the installer to ensure proper light levels and delay are selected to provide the most effective operation in different lighting conditions.

The photo sensor detects ambient light levels, so parking the vehicle under a bright street light during night-time use may (CLEAR) turn off the photo sensor input. Likewise, driving through a dark tunnel during daytime use may (SET) the photo sensor input. Ensure the operator of the vehicle is aware of such possible conditions and provide additional controls to the breakout box to allow the operator the ability to manually over-ride the functions when required.

Changing the ambient light SET/CLEAR levels may be modified by updating the setting in the 'Photo Sensor' tab in the PC Application.

The photo sensor controls may be updated by using the PC App. Refer to the PC App instructions for more detail.

## PHOTO SENSOR OVER-RIDE CONFIGURATION INSTRUCTIONS

1. Click on 'Breakout Box Inputs' tab and click on 'P1: Photo Sensor' and note priority and which functions are activated when the photo sensor is active.



### NOTICE:

Installers and users must comply with all applicable federal, state and local laws regarding use and installation of warning devices.

*Improper use or installation may void warranty coverage.*

To review our *Limited Warranty Statement & Return Policy* for this or any SoundOff Signal product, visit our website at [www.soundoffsignal.com/tech-services/returns/](http://www.soundoffsignal.com/tech-services/returns/).

If you have questions regarding this product, contact **Technical Services**, Monday - Friday, 8 a.m. to 5 p.m. ET at 1.800.338.7337 (press #4).

Questions or comments that do not require immediate attention may be emailed to [techservices@soundoffsignal.com](mailto:techservices@soundoffsignal.com).

## PHOTO SENSOR OVER-RIDE CONFIGURATION INSTRUCTIONS (CONT.)

2. Click on the input wire/siren control to be used to over-ride the functions activated by the photo sensor and change the priority of the selected input wire/siren control to be a higher priority than the photo sensor control priority. Set the functions activated by the photo sensor to 'Turn Function OFF' (Red button) when the input wire/siren control is active.

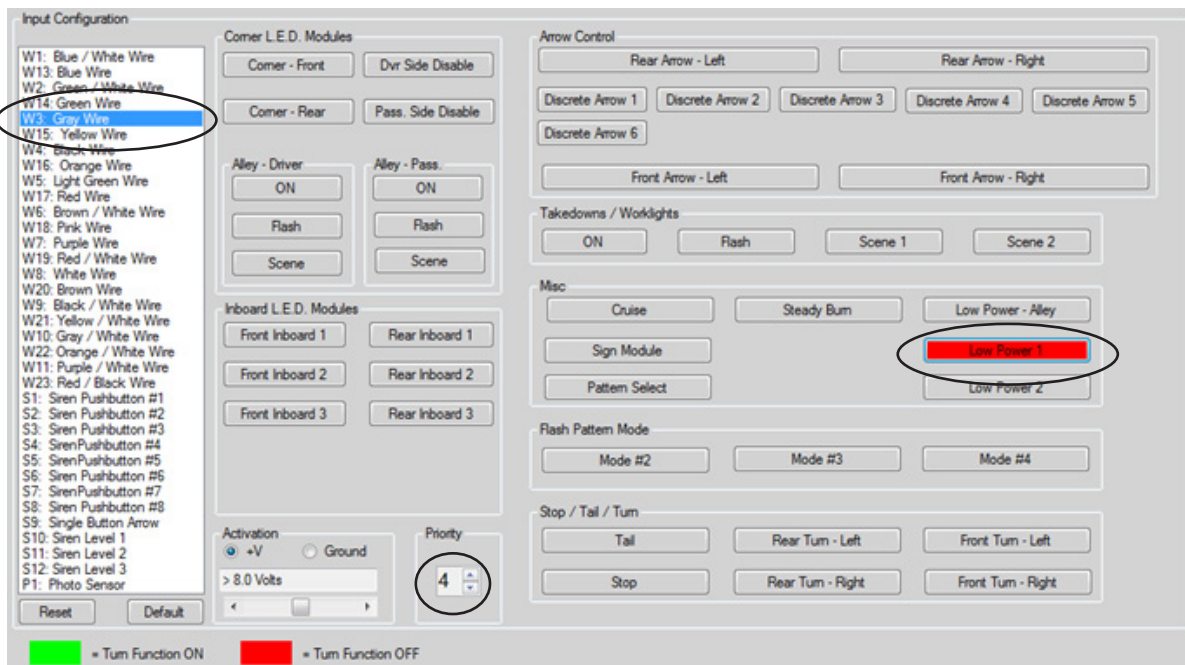

3. From the example in #2, when +V is applied to the gray wire, Low Power 1 will be turned off even if the photo sensor is active since the gray wire control is a higher priority than the photo sensor control.

### NOTICE:

Installers and users must comply with all applicable federal, state and local laws regarding use and installation of warning devices.

*Improper use or installation may void warranty coverage.*

To review our Limited Warranty Statement & Return Policy for this or any SoundOff Signal product, visit our website at [www.soundoffsignal.com/tech-services/returns/](http://www.soundoffsignal.com/tech-services/returns/).

If you have questions regarding this product, contact **Technical Services**, Monday - Friday, 8 a.m. to 5 p.m. ET at 1.800.338.7337 (press #4).

Questions or comments that do not require immediate attention may be emailed to [techservices@soundoffsignal.com](mailto:techservices@soundoffsignal.com).

## BREAKOUT BOX INSTRUCTIONS: (LIN COMMUNICATION)

- Securely snap in the 24-pin and the RJ-45 connectors.
- Refer to Table 1 for the input wire's default function.
- Follow the label for the wire color to connect to a 12 Vdc source, which turns on that given light or lights.
- Make sure your wire connections are secured and isolated from any other wire.

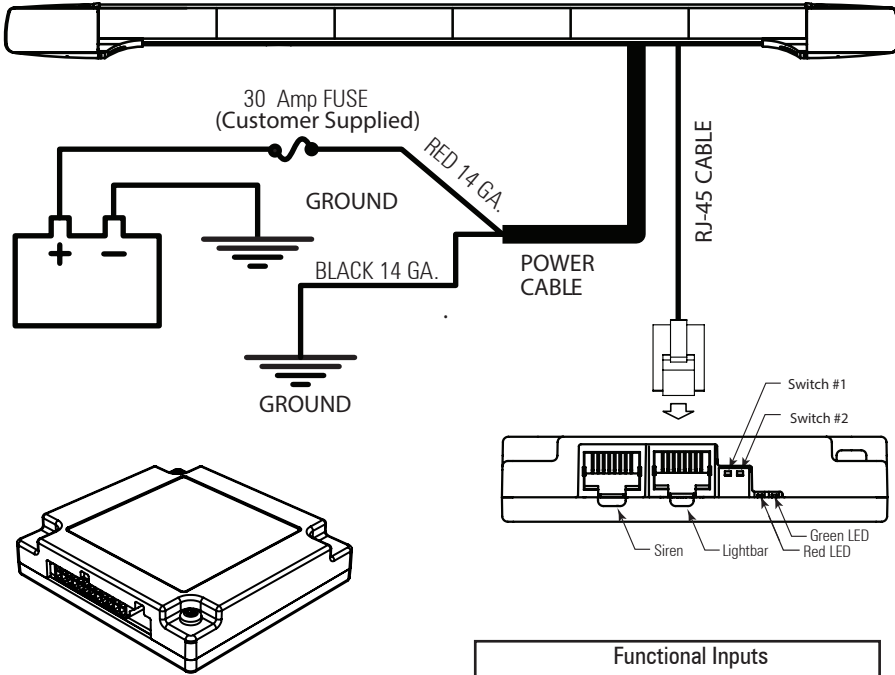
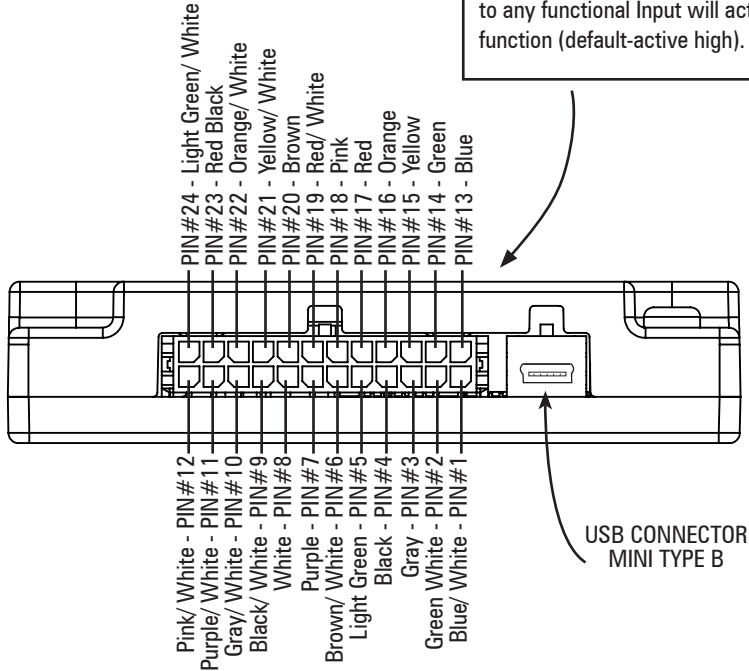

Table 1

Wire Pin #	Wire Color	Wire Function
1	Blue/White	Rear Corners
2	Green/White	Rear Inboard 1
3	Gray	Mode Select
4	Black	Cruise Mode
5	Light Green	Scene Lighting
6	Brown/White	Takedown Flash
7	Purple	Low Power
8	White	Pattern Select / Tail
9	Black/White	Left Turn
10	Gray/White	Arrow - Right
11	Purple/White	Arrow - Left
12	Pink/White	Ignition Input
13	Blue	Front Corners
14	Green	Front Inboard 1
15	Yellow	Front Inboard 2
16	Orange	Front Inboard 3
17	Red	Alley Passenger
18	Pink	Alley Driver
19	Red/White	Alley Flash
20	Brown	Takedown
21	Yellow/White	Rear Inboard 2
22	Orange/White	Rear Inboard 3
23	Red/Black	Right Turn
24	Light Green/White	Future Use - Sync 2

**Functional Inputs**  
Functional Inputs connect to your control head or switching unit. Applying +12Vdc to any functional Input will activate it's function (default-active high).



Connector Pinning Chart

24	23	22	21	20	19	18	17	16	15	14	13	
Ignition	12	11	10	9	8	7	6	5	4	3	2	1

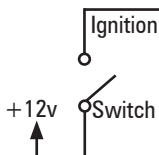

## CAN BREAKOUT BOX INSTRUCTIONS: (CAN COMMUNICATION)

- Securely snap in the 2-pin, 24-pin, and RJ45 connectors
- Refer to Table 1 for the input wire default functions and to Table 2 for the CAN wire functions
- Follow the label for the wire color to connect to a 12 Vdc source, which turns on that given light or lights
- Make sure your wire connections are secured and isolated from any other wire
- If extending the 2-pin harness, a shielding wire running the length of the entire harness may be necessary

Table 2

Wire Pin	Color	Function
3	Green	CAN Low
5	Yellow	CAN High

CAN CONNECTOR

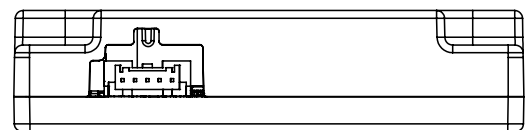

CONNECTOR PRESENT WITH CAN BOB



## LIGHT MODULE WIRE HARNESS LOCATIONS

**12" Inboard Tub  
Front**

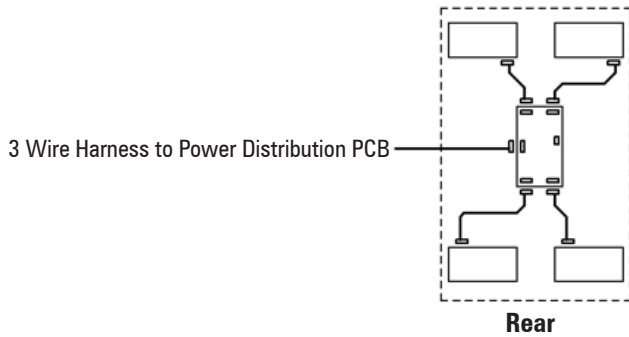

**Driver Side End Tub  
Front**

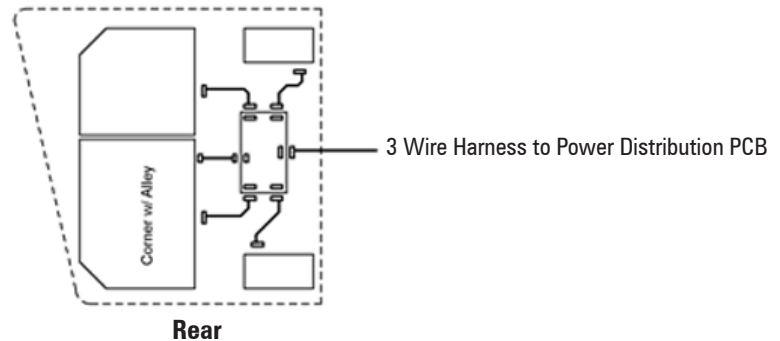

**6" Inboard Tub  
Front**

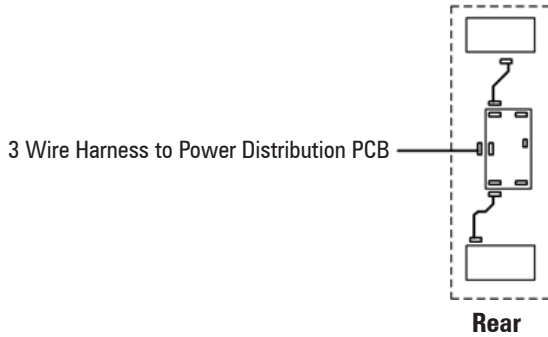

**Passenger Side End Tub  
Front**

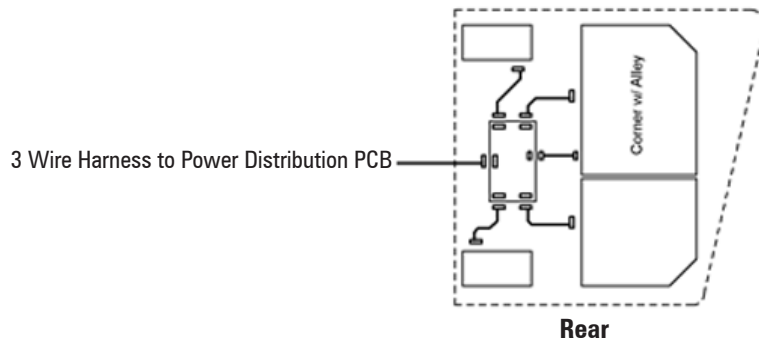

### REPLACEMENT OF INBOARD AND CORNER MODULES:

1. Disconnect main power.
2. Remove top cover by removing screws.
3. Locate module. If it has a bracket, remove the screw (if no bracket skip this step).
4. Push down on black tab to un-clip the module.
5. Remove connector from rear of module by carefully pulling connector body from back of module.
6. Push module connector into replacement module ensuring locking latch is seated properly or connector is fully seated.
7. Replace screw if the module has a bracket (if no bracket skip this step).
8. Restore power to bar and test new module to ensure functionality.
9. Replace top cover of bar with screws removed in step 2.

#### NOTICE:

Installers and users must comply with all applicable federal, state and local laws regarding use and installation of warning devices.

*Improper use or installation may void warranty coverage.*

To review our Limited Warranty Statement & Return Policy for this or any SoundOff Signal product, visit our website at [www.soundoffsignal.com/tech-services/returns/](http://www.soundoffsignal.com/tech-services/returns/).

If you have questions regarding this product, contact **Technical Services**, Monday - Friday, 8 a.m. to 5 p.m. ET at **1.800.338.7337** (press #4).

Questions or comments that do not require immediate attention may be emailed to [techservices@soundoffsignal.com](mailto:techservices@soundoffsignal.com).

**Driver Module Replacement:**

- Verify power has been removed from lightbar before attempting service
- Remove top cover
- Unplug 3 pin power/data connector and LED module connectors from driver module assembly, noting location.
- Remove driver module
- Snap new driver module assembly into housing
- Plug 3 pin power/data connector and LED module connectors into driver module assembly
- Set DIP switch according to lightbar length and driver module location as shown below:
- Apply power to lightbar and verify proper operation.
- Set Switch #2 on Breakout Box to Down position then to Up position to store configuration into new driver module
- Verify DIP switch settings if lightbar does not function properly, and repeat step 'i' if DIP switch setting is changed

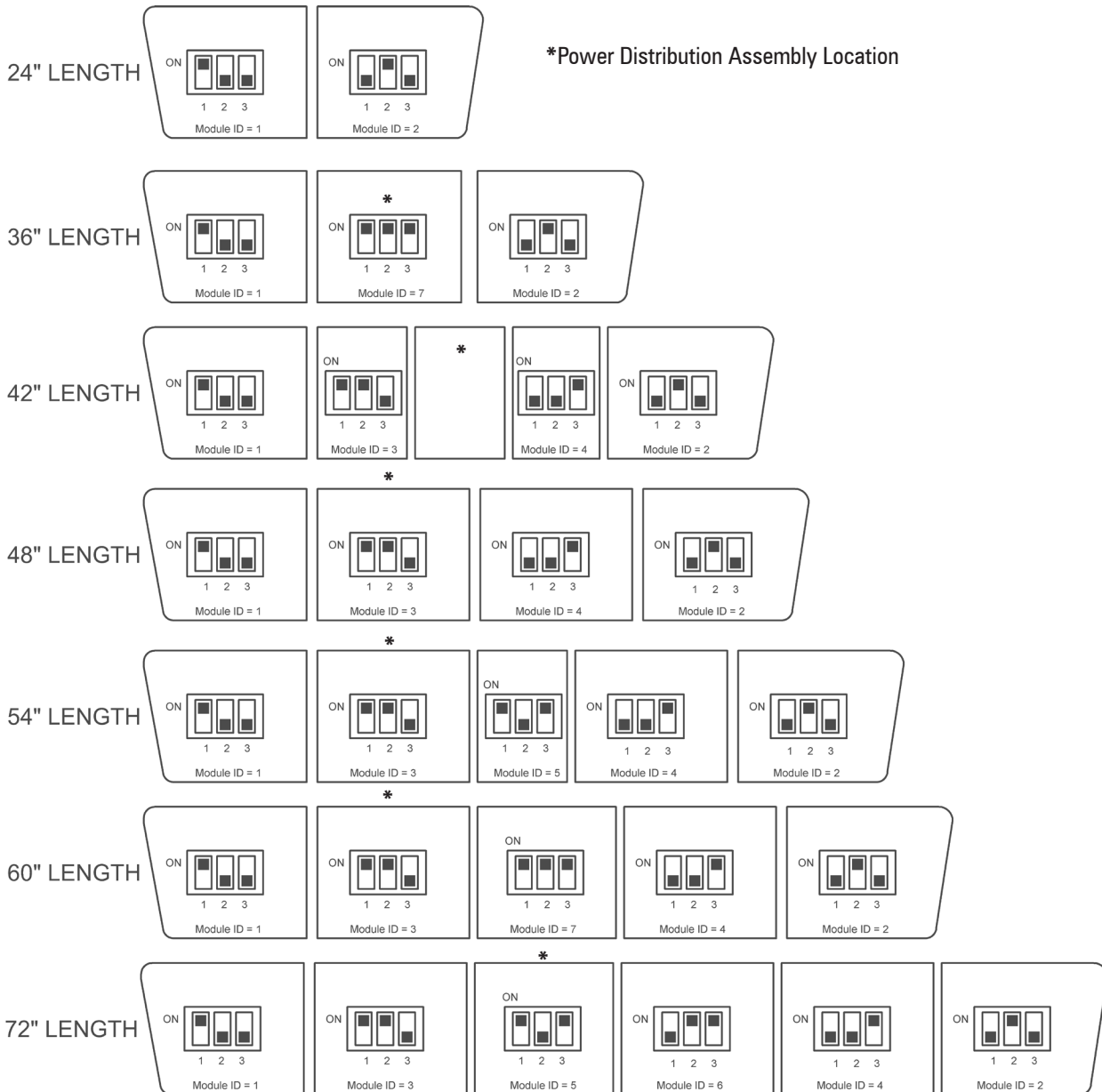

**Setting Light-bar Length: (Length comes preset from factory)**

**\*\* NOTE: Entering this configuration mode, will reset the light-bar to factory defaults**

- a. Set Switch #1 and Switch #2 on Breakout box to down position
- b. Momentarily apply voltage to pattern select wire to change the length of the light-bar configuration
  - a. 24" Red LED OFF, Green LED OFF
  - b. 36" Red LED OFF, Green LED Flashes 1 Time
  - c. 42" Red LED OFF, Green LED Flashes 2 Times
  - d. 48" Red LED OFF, Green LED Flashes 3 Times
  - e. 54" Red LED ON, Green LED OFF
  - f. 60" Red LED ON, Green LED Flashes 1 Time
  - g. 72" Red LED ON, Green LED Flashes 2 Times
- c. Repeat step 'b' until correct light-bar length is selected
- d. Set Switch #1 and Switch #2 on Breakout box to Up position to store light-bar length

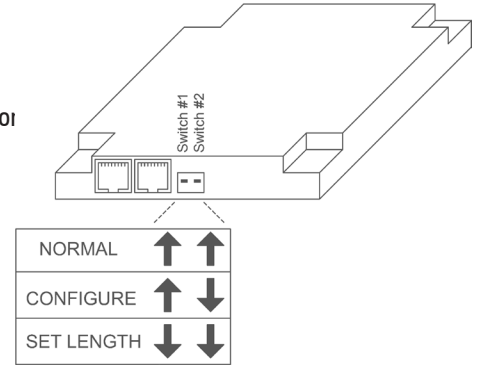

**NOTE: For settings above, Switch #2 does not need to be moved to the up position after each configuration. The switch can remain in the down position until the lightbar is completely configured and then moved to the Up position to store all the settings.**

**NOTICE:**

Installers and users must comply with all applicable federal, state and local laws regarding use and installation of warning devices.

*Improper use or installation may void warranty coverage.*

To review our Limited Warranty Statement & Return Policy for this or any SoundOff Signal product, visit our website at [www.soundoffsignal.com/tech-services/returns/](http://www.soundoffsignal.com/tech-services/returns/).

If you have questions regarding this product, contact **Technical Services**, Monday - Friday, 8 a.m. to 5 p.m. ET at **1.800.338.7337** (press #4).

Questions or comments that do not require immediate attention may be emailed to [techservices@soundoffsignal.com](mailto:techservices@soundoffsignal.com).

## nForce TROUBLESHOOTING

### **NORMAL OPERATION**

Under Normal operation with lightbar turned ON, the breakout box will have the Green LED flash approx every 5 seconds and the Red LED light will be on steady whenever an input is active and both switches will be in the UP (off) position. Each driver module inside the lightbar has a fused circuit from the power distribution module. The LED on the driver module will flash whenever there is an active function selected on the breakout box.

### **NO OPERATION**

No Green LED flashing on Breakout box;

Check input power and ground to lightbar, check data cable for damage and/or opens.

**Check Ignition Input wire and verify a minimum of 10.0 Volts is present on the wire**

Defective power distribution assembly – replace.

### **NO or INCORRECT INBOARDS or CORNERS LIGHTS (WARNING)**

Breakout box LED's operating correctly;

Check DIP switches on driver modules in lightbar. Verify they are all set correctly

No steady Red LED on breakout box;

Check 24-pin connector at breakout box (insure it is snapped in correctly), check appropriate input to breakout box for output lights which should be on. Verify voltage is present at the wire input to the breakout box for the function being tested

### **NO TAKEDOWNS LIGHTS**

Breakout box LED's operating correctly;

Verify configuration and make sure light modules are configured for takedown function

No steady Red LED on breakout box;

Check 24-pin connector at breakout box (insure it is snapped in correctly), check appropriate input to breakout box for output lights which should be on

### **NO LIGHT OPERATION IN ONLY 1 TUB**

Breakout box LED's operating correctly;

Remove top cover of tub in which lights are not functioning. Verify DIP switch is set correctly.

Check LED on Driver Module PCB is flashing when power is applied to any input wire on breakout box. If there is no LED illumination check for voltage across Red and Black power input wires to driver module. If voltage is present, replace driver module. If voltage is not present, locate the power distribution PCB (possibly in different tub) and verify fuse is not blown open. If fuse is blown, check for shorts in cabling replace any damaged cables and replace fuse. If fuse blows again, replace defective driver module assembly.

### **INCORRECT OR NO ARROW OPERATION**

Breakout box LED's operating correctly;

Verify configuration and make sure light modules are configured for arrow function

**Verify lightbar length is properly set – note that entering mode will reset lightbar to factory defaults.**

No steady Red LED on breakout box;  
to

Check 24-pin connector at breakout box (insure it is snapped in correctly), check appropriate input breakout box for output lights which should be on.

## Connection of Lightbar Breakout Box to SoundOff Signal Siren:

Note: Requires PC configuration app to map siren control switches to lightbar functions

Plug 1 end of RJ-45 cable to available jack on siren amplifier

Plug other end of RJ-45 cable to 'siren'

### ETSA380R or ETSA385HR

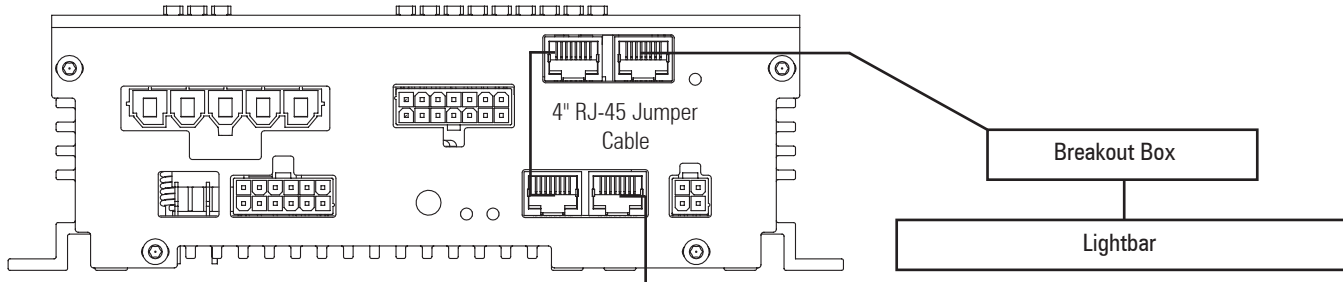

### ETSA481CSR or ETSA482CSR

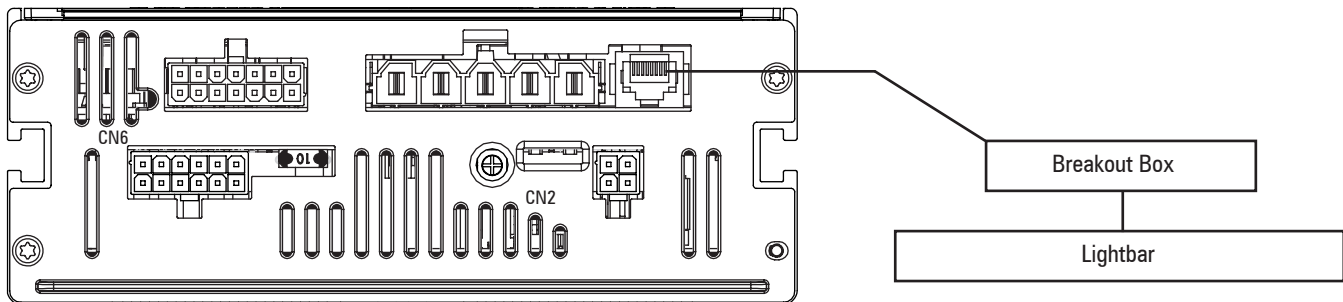

### ETSA481RSP, ETSA482RSP, ETSA461HPP, ETSA462HPP

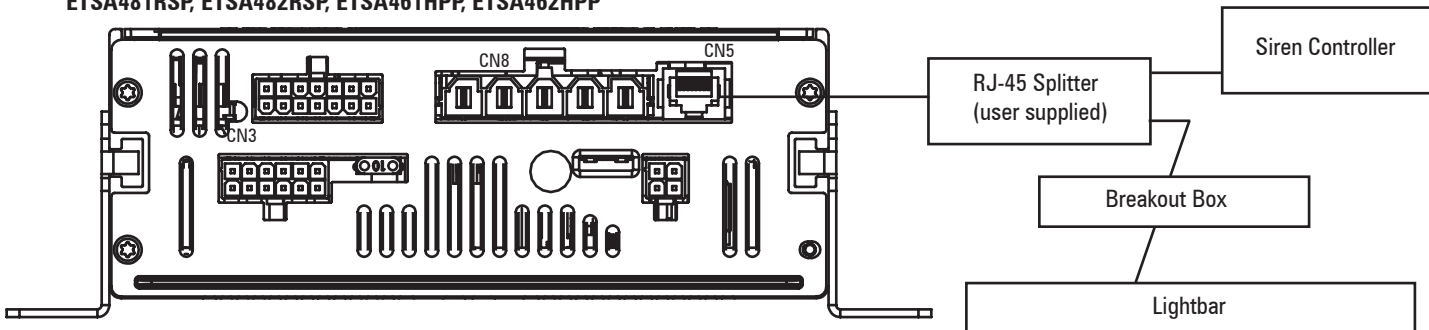

**QUICK CONNECT HARNESS**

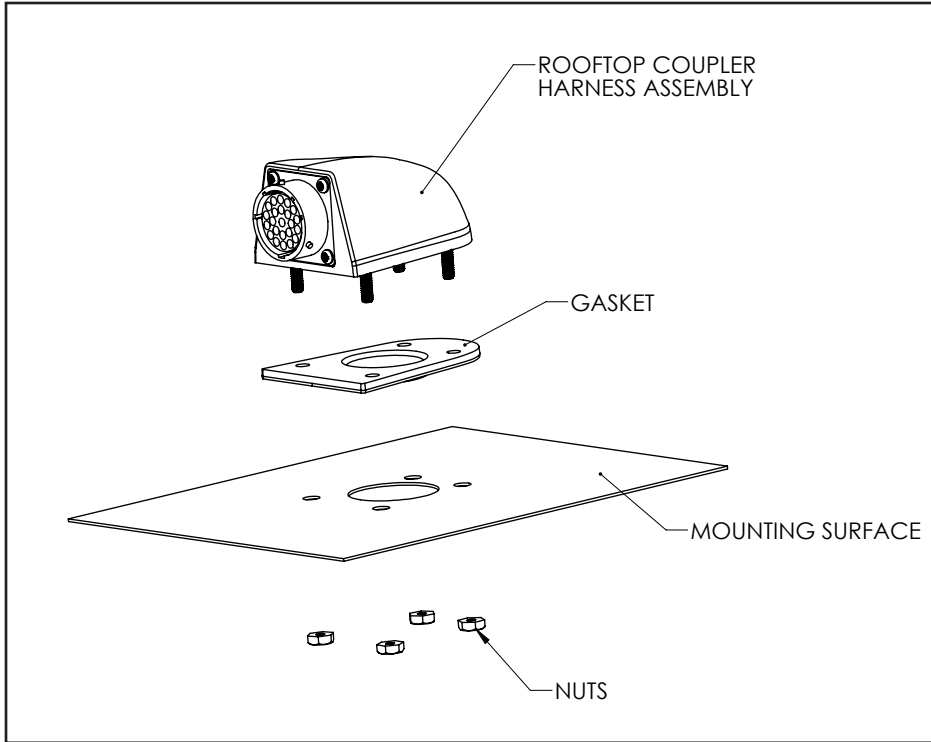

**INSTALLATION:**

1. Before drilling all holes, mask an area where the rooftop connector and lightbar harness will be placed on the apparatus to which it will be installed.
2. Drill center 1 5/16" hole for the gasket clearance.
3. Using the gasket as a template, mark the four (4) bolt holes and drill 1/4" holes for the housing studs.
4. Place the gasket and rooftop connector assembly on top of the mounting surface. Secure the four (4) studs using supplied hardware.

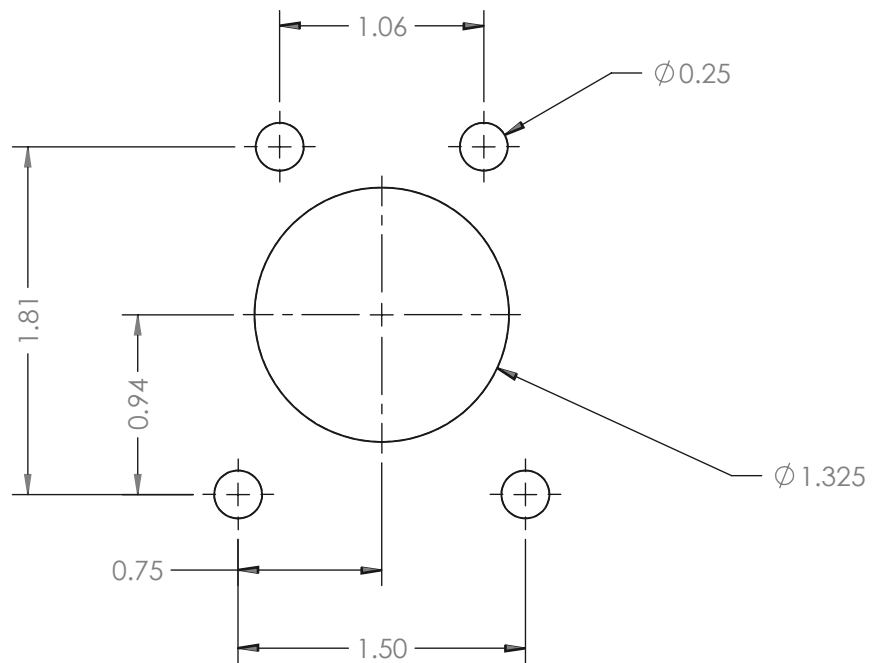

MOUNTING HOLE PATTERN

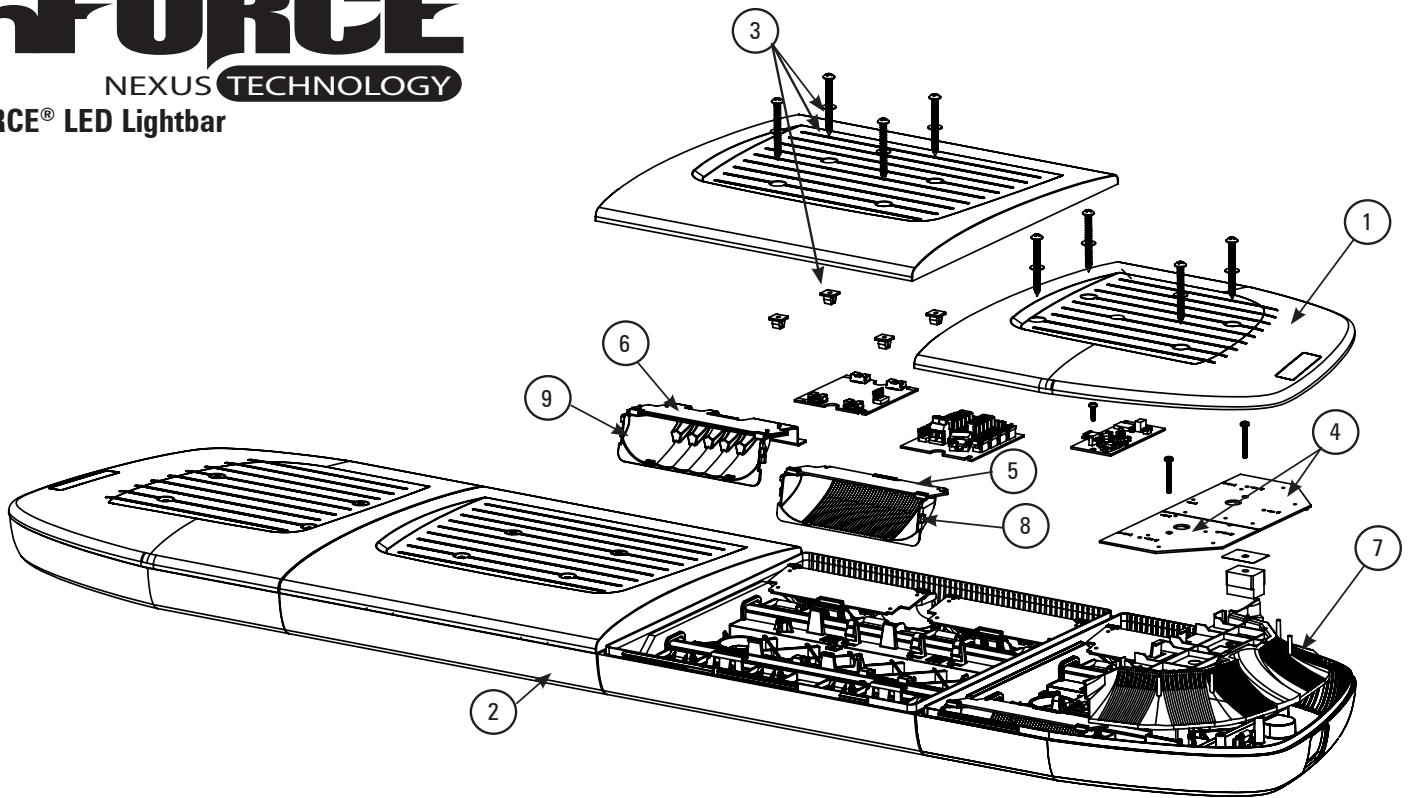

## REPLACEMENT PARTS & ACCESSORIES

ITEM #	PART#	DESCRIPTION
	PNFLBK00	STANDARD FIXED HEIGHT MOUNT - THIN PAD
	PNFLBF00	FIXED HEIGHT PERMANENT MOUNT HOOK KIT
	PNFLBK02	HEADACHE RACK MOUNT
	PETLF00	FIXED HEIGHT PERMANENT MOUNT KIT
	PNFLBK03	MAGNETIC MOUNT FOOT KIT (24" ONLY)
	PNFLBK04	STANDARD FIX HEIGHT MOUNT - 48" TAHOE
	PNFLBK05	STANDARD FIX HEIGHT MOUNT - 54" TAHOE
	PNFLBF(xx)	HOOK BRACKET KITS
	PNFLBJ00	BREAKOUT BOX
	PNFLBHNDT1	BREAKOUT BOX DATA CABLE
	PNFLBHNPW1	POWER HARNESS
	PNFLBHND5(xx)	DISTRIBUTION HARNESSES
	PNFLBHNMD(x)	MODULE HARNESSES
	PNFLBHNAL1	ALLEY HARNESS
	PNFLBWMKT1	WIRE MANAGEMENT KIT
	PNFLBWGKT1	WEDGE KIT
	PNFLBHPKT1	HOLE PLUG KIT
	PNFLBFTCV1	STANDARD FIXED HEIGHT FOOT CAP REPLACEMENT
3	PNFLBTCST1	TOP COVER SCREW KIT
	PNFLBDST(x)	DISTRIBUTION BOARDS
	PNFLBDRV(x)	DRIVER BOARDS
	PNFLBHNPW2	nFORCE® LIGHTBAR HARNESS - QUICK CONNECT (LIGHTBAR SIDE)
	PNFLBHNPW3	nFORCE® LIGHTBAR HARNESS - QUICK CONNECT (VEHICLE SIDE)
	PNFLBTRDRL(xx)	AUTO DIM RETRO FIT KIT
	PNFLBDAD1	AUTO DIM DRIVER BOARD

ITEM #	PART#	DESCRIPTION
1	PNFLBTT(xx)LGY	TOP COVERS - GRAY GELOY
2	PNFLBTB(xx)L(x)	BOTTOM LENSES
4	PNFLBCSS112(x)	12 LED CORNER MODULES - SMALL
4	PNFLBCSS118(x)	18 LED CORNER MODULES - SMALL
4	PNFLBCSD124(x)	24 LED DUAL CORNER MODULES - SMALL
4	PNFLBCST130(xxx)	30 LED TRI CORNER MODULES - SMALL
4	PNFLBCLS112(x-Z)	12 LED CORNER MODULES - LARGE NO ALLEY
4	PNFLBCLS118(x-Z)	18 LED CORNER MODULES - LARGE NO ALLEY
4	PNFLBCLD124(x-Z)	24 LED DUAL CORNER MODULES - LARGE NO ALLEY
4	PNFLBCLT130(xxx)-Z	30 LED TRI CORNER MODULES - LARGE NO ALLEY
	PNFLBCLS112(x)-W	12 LED CORNER MODULES - LARGE WITH ALLEY
	PNFLBCLS118(x)-W	18 LED CORNER MODULES - LARGE WITH ALLEY
	PNFLBCLD124(x)-W	24 LED DUAL CORNER MODULES - LARGE WITH ALLEY
	PNFLBCLT130(xxx)-W	30 LED TRI CORNER MODULES - LARGE WITH ALLEY
5	PNFLBLS106(x)	6 LED INBOARD MODULES
5	PNFLBHS106A	ECE 6 LED INBOARD - AMBER
5	PNFLBLS109(x)	9 LED INBOARD MODULES
5	PNFLBLD112(x)	12 LED DUAL INBOARD MODULES
5	PNFLBHD112(x)	ECE 12 LED INBOARD - DUAL COLOR
5	PNFLBLT118(xxx)	18 LED TRI INBOARD MODULES
6	PNFLBHS106W	TAKEDOWN/WORKLIGHT MODULE - DUAL
9	PNFLBRFTD1	TD/WL REFLECTOR
8	PNFLBRFL845	INBOARD REFLECTOR
7	PNFLBRFC845(x)	CORNER REFLECTOR

## WARRANTY & RETURN GOODS PROCEDURE

### **CLEANING & CARE OF YOUR LIGHTBAR:**

Keeping the lenses clean and scratch free will optimize the performance of the lightbar. The exterior of the lightbar including lenses should be cleaned with mild soapy water and a soft cotton cloth to remove dirt, grime and insects. Never use window cleaners or harsh chemicals on the lenses; this may cause failure of the lenses or reduce clarity resulting in the reduction of light output.

### **MOUNTING INTEGRITY:**

A review of bolt/hardware/mounting bracket integrity should be performed at the beginning and end of each shift.

### **WARNING MESSAGES - PLEASE READ:**

**WARNING** - DRILLING ANY HOLES INTO THE LIGHTBAR IS NOT RECOMMENDED! THE RISK OF DAMAGING INTERNAL COMPONENTS AND THE RESULTING FAILURE OF THE LIGHTBAR WILL VOID ANY WARRANTY OF THIS PRODUCT.

**WARNING** - CARE MUST BE TAKEN WHEN DRILLING THROUGH THE ROOF OF THE VEHICLE NOT TO DRILL INTO ANY EXISTING WIRING AND NOT TO DRILL THROUGH THE HEADLINER OR SUPPORT MEMBERS OF THE VEHICLE. CHECK BOTH SIDES OF THE MOUNTING SERVICE PRIOR TO DRILLING. DE-BURR ANY HOLES AND REMOVE ANY METAL SHARDS OR REMNANTS. INSTALL GROMMETS INTO ALL WIRE PASSAGE HOLES.

**WARNING** - ROUTE WIRES ONLY IN LOCATIONS THAT ARE NOT SUBJECTED TO POTENTIAL WEAR. MAKE SURE TO AVOID ROUTING WIRES IN THE DEPLOYMENT AREA OF YOUR AIR BAG. REFER TO YOUR VEHICLE OWNER'S MANUAL FOR AIR BAG DEPLOYMENT ZONES.

**WARNING** - ALL CUSTOMER SUPPLIED POWER WIRES CONNECTING TO THE POSITIVE (+) OR NEGATIVE (-) BATTERY TERMINAL OR LOCAL CHASSIS GROUND (-) MUST BE SIZED TO SUPPLY AT LEAST 125% OF THE MAXIMUM CURRENT AND PROPERLY FUSED AT THE POWER SOURCE WITH APPROPRIATELY RATED FUSE.

**IMPORTANT:** When passing cables through fire wall or other sheet metal, insert grommet to protect the cable!

### **WARRANTY RETURN PROCESS:**

Please contact your SoundOff Signal Sales Representative, Customer Services staff or our Technical Department (800.338.7337) for a RMA #, Return Merchandise Authorization Number.

The following information is required for issuance of the RMA #:

- Reason for returning the product\*
- Address where replacement product is to be shipped\*
- Telephone number where you may be reached\*
- SoundOff Signal invoice number on which product was purchased\*\*
- SoundOff Signal part number and serial number\*\*
- E-mail address where RMA # should be e-mailed\*\*
- Fax number where RMA # should be faxed\*\*

\* RMA # will not be given without this information.

\*\* If available, please provide this information.

SoundOff Signal will NOT accept returns without an RMA #. Each RMA # is good for only one (1) return and will expire (30) days after the date it was issued. Products must be shipped back to SoundOff Signal and the RMA # clearly marked on the outside of the package near the shipping label. Please use the following address on your shipping label:

SoundOff Signal  
ATTN: RMA # / Technical Services  
3900 Central Parkway  
Hudsonville, MI 49426

### **WARRANTY EXCLUSIONS:**

Shipping & Handling, labor and service fees are non-refundable. SoundOff Signal is not liable for any damage due to installation or personal injury as a result of using SoundOff Signal product.

### **WARRANTY FORFEITURE:**

Warranty will not be granted if the Warranty Return Policy & Procedure rules are not strictly followed. Physical damage resulting from customer abuse will void warranty. Warranty will also be voided if any SoundOff Signal and/or manufacturer serial tags, product stickers, seals, or the like, are removed, altered or tampered with. Returned product that is damaged by shipping via the RMA # procedure is not the responsibility of SoundOff Signal.

Document effective date on cover and below supersedes previously dated policies and statements.

There are no other warranties, expressed or implied, including, but not limited to, any implied merchantability or fitness for a particular use. SoundOff Signal reserves the right to modify this warranty statement at any time; or to discontinue, modify, or upgrade any products of its manufacture with design improvements without prior notice.

### **NOTICE:**

Installers and users must comply with all applicable federal, state and local laws regarding use and installation of warning devices.

*Improper use or installation may void warranty coverage.*

To review our Limited Warranty Statement & Return Policy for this or any SoundOff Signal product, visit our website at [www.soundoffsignal.com/tech-services/returns/](http://www.soundoffsignal.com/tech-services/returns/).

If you have questions regarding this product, contact **Technical Services**, Monday - Friday, 8 a.m. to 5 p.m. ET at 1.800.338.7337 (press #4).

Questions or comments that do not require immediate attention may be emailed to [techservices@soundoffsignal.com](mailto:techservices@soundoffsignal.com).