

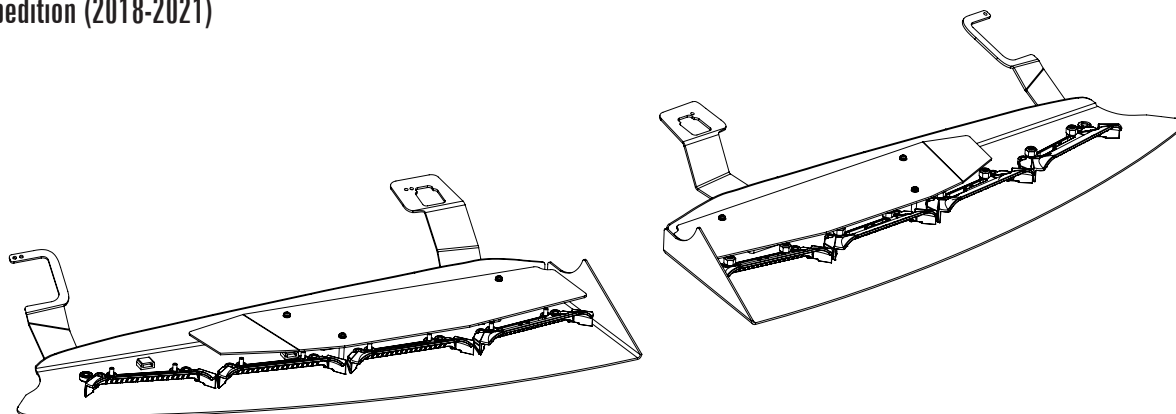

## Interior Split Two-Piece Lightbar Ford Expedition (2018-2021)



### ⚠ WARNING

- HIGH CURRENT interconnects must be properly terminated. Poor crimp quality can cause heat build-up and fire. Follow crimp connector manufacturer instructions.
- DO NOT install this product or route any wires in the Air Bag Deployment Zone. Refer to vehicle Owner's Manual for deployment zones.
- Do NOT use system to disconnect headlights, brake lights or other safety equipment.
- Unit may become hot to touch during normal operation.
- Failure to properly install connectors, fuses or wiring may cause vehicle failure or fire.
- Installation must only be performed by trained technician. Installer must determine vehicle wiring configuration and proper integration of system.
- Use proper wire gauge. All power wires connecting to positive (+) or negative (-) battery terminal or local chassis ground (-) must be sized to supply at least 125% of max. current and properly fused at power source.
- Install protective grommets when routing wire through firewall or metal.



1.800.338.7337 / www.soundoffsignal.com

### INTRODUCTION:

Design highlights for 2018-2020 Ford Expedition Front Interior nFORCE® Lightbar:

- 8 module, split 2 Piece shroud design
- Improved wire management incorporated into design
- Powder coat is smoother, less textured, than traditional SoundOff Signal® interior lightbars

### CONTAINS

QTY	COMPONENT
1	Windshield Shroud, Passenger Side
1	Outer Hanging Bracket, Passenger Side
1	Inner Hanging Bracket, Passenger Side
1	Windshield Shroud, Driver Side
1	Outer Hanging Bracket, Driver Side
1	Inner Hanging Bracket, Driver Side
4	1/4"-20 x 3/8" Black Pan Phillips M-S
4	1/4" Black Star Washer
1	Thin Trim
1	Product Warning Card
1	Installation Instruction Sheet

### ⚠ WARNING

This product contains high intensity LED devices. To prevent eye damage, DO NOT stare into the light beam at close range.

### NOTICE:

Installers and users must comply with all applicable federal, state and local laws regarding use and installation of warning devices.

*Improper use or installation may void warranty coverage.*

To review our Limited Warranty Statement & Return Policy for this or any SoundOff Signal product, visit our website at [www.soundoffsignal.com/tech-services/returns/](http://www.soundoffsignal.com/tech-services/returns/).

If you have questions regarding this product, contact **Technical Services**, Monday - Friday, 8 a.m. to 5 p.m. ET at 1.800.338.7337 (press #4).

Questions or comments that do not require immediate attention may be emailed to [techservices@soundoffsignal.com](mailto:techservices@soundoffsignal.com).

ENHANCING SAFETY THROUGH INNOVATION



## Interior Split Two-Piece Lightbar Ford Expedition (2018-2021)

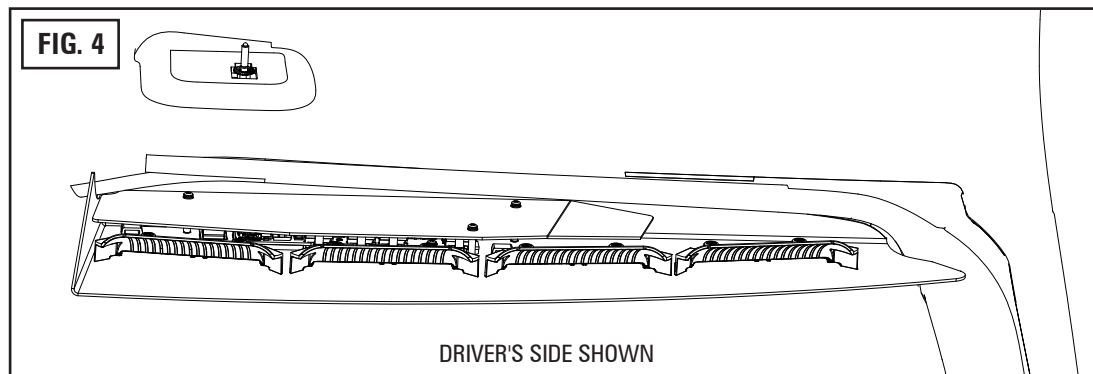
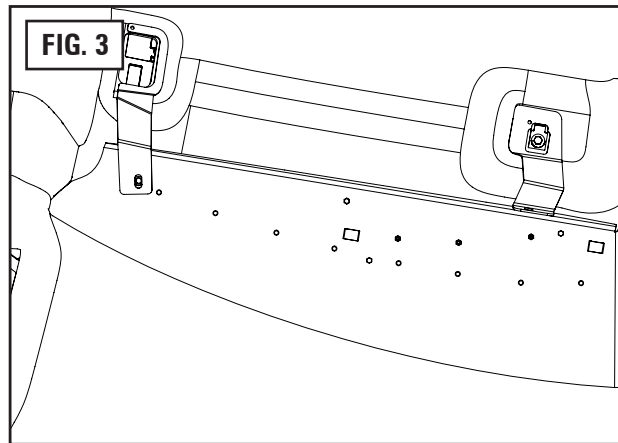
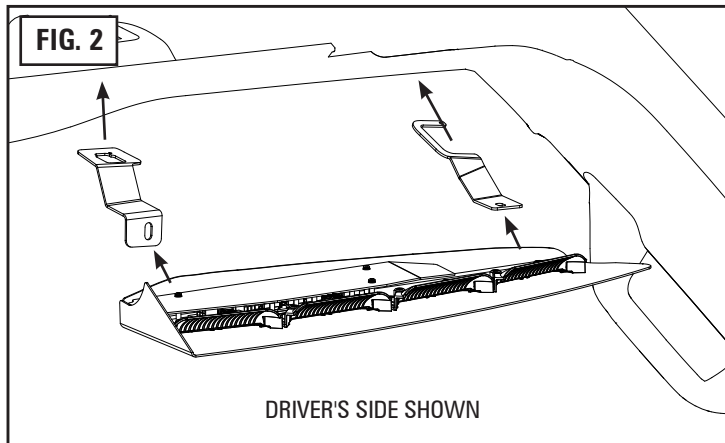
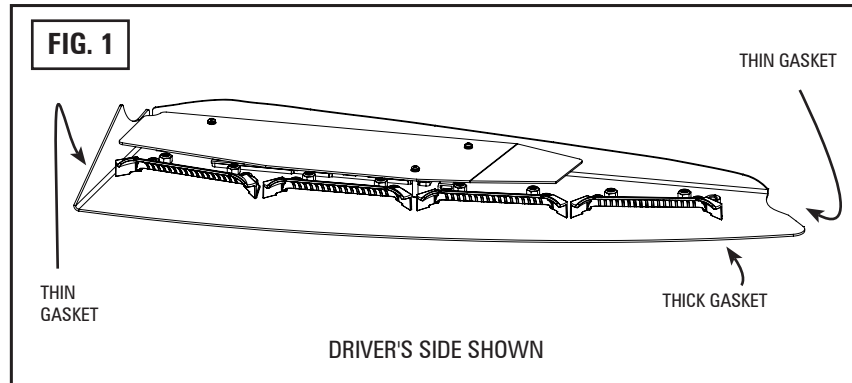

### INSTALLATION:

1. We recommend using the thin gaskets provided and apply to the specified edges called out on Fig 1.
2. Pull the clip off the outside of the interior visor. After removing the cover clip, pull out the 3 screws.
3. As seen in Fig. 2, use the correct bracket to line up the 3 holes where the screws had been. Place the bracket onto those holes and put the OEM screws back into their location. Leaving the cover clip off, tighten screws down.

**PRO TIP:** Use the holes on the bracket to identify which is driver and which is passenger side. The driver side has 1 hole while the passenger side has 2 holes.

4. To install the inside bracket, remove the screw from the inside of the visor clip. This will loosen the visor clip. Slide the bracket underneath the visor clip, as seen in Fig 3.
5. If you need to, pull the clip out and reinstall the visor clip, ensuring the bracket is underneath. When the bracket is underneath the visor clip, screw the OEM screw back in. Leave the screw loose for adjustability when installing the shroud.
6. Take the shroud and position it in the car. Screw the 1/4"-20 bolt into the shroud. The brackets are slotted for adjustment, as needed.
7. When the shroud is in position, tighten down to the brackets.
8. Tighten down the inside visor clip screw left loose in Step 4.
9. Repeat Steps 1-7 for the other side's shroud installation.

### OPERATION:

SEE 'ELECTRICAL INSTALLATION' SECTION OF THE nFORCE LED INTERIOR LIGHTBAR INSTALLATION PACKET.

### NOTICE:

Installers and users must comply with all applicable federal, state and local laws regarding use and installation of warning devices.

*Improper use or installation may void warranty coverage.*

To review our Limited Warranty Statement & Return Policy for this or any SoundOff Signal product, visit our website at [www.soundoffsignal.com/tech-services/returns/](http://www.soundoffsignal.com/tech-services/returns/).

If you have questions regarding this product, contact **Technical Services**, Monday - Friday, 8 a.m. to 5 p.m. ET at 1.800.338.7337 (press #4).

Questions or comments that do not require immediate attention may be emailed to [techservices@soundoffsignal.com](mailto:techservices@soundoffsignal.com).

