

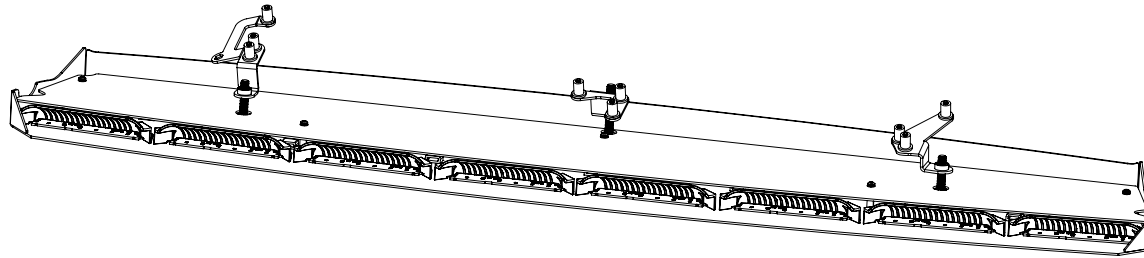

**Interior Rear Lightbar**  
2021 Chevrolet Tahoe



**⚠ WARNING**

- HIGH CURRENT interconnects must be properly terminated. Poor crimp quality can cause heat build-up and fire. Follow crimp connector manufacturer instructions.
- DO NOT install this product or route any wires in the Air Bag Deployment Zone. Refer to vehicle Owner's Manual for deployment zones.
- Do NOT use system to disconnect headlights, brake lights or other safety equipment.
- Unit may become hot to touch during normal operation.
- Failure to properly install connectors, fuses or wiring may cause vehicle failure or fire.
- Installation must only be performed by trained technician. Installer must determine vehicle wiring configuration and proper integration of system.
- Use proper wire gauge. All power wires connecting to positive (+) or negative (-) battery terminal or local chassis ground (-) must be sized to supply at least 125% of max. current and properly fused at power source.
- Install protective grommets when routing wire through firewall or metal.

**NOTICE:**

Installers and users must comply with all applicable federal, state and local laws regarding use and installation of warning devices.

*Improper use or installation may void warranty coverage.*

To review our Limited Warranty Statement & Return Policy for this or any SoundOff Signal product, visit our website at [www.soundoffsignal.com/tech-services/returns/](http://www.soundoffsignal.com/tech-services/returns/). If you have questions regarding this product, contact **Technical Services**, Monday - Friday, 8 a.m. to 5 p.m. or after hours 5 p.m. to 8 p.m. ET at **1.800.338.7337** (press #4). Questions or comments that do not require immediate attention may be emailed to [techservices@soundoffsignal.com](mailto:techservices@soundoffsignal.com).

**INTRODUCTION:**

Design highlights for 2021 Tahoe nFORCE® Lightbar for Rear Interior:

- 8 module, full shroud design
- Top cover incorporated into this rear interior lightbar design, for improved look and installation
- Improved wire management incorporated into design
- Powder coat is smoother, less textured, than traditional SoundOff Signal® interior lightbars

| CONTENTS |                          |
|----------|--------------------------|
| QTY      | COMPONENT                |
| 1        | SHROUD                   |
| 1        | BRACKET, PASSENGER SIDE  |
| 1        | BRACKET, CENTER POSITION |
| 1        | BRACKET, DRIVER SIDE     |
| 2        | 1/4"-20 x 2" SCREW       |
| 1        | 1/4"-20 x 2.5" SCREW     |
| 9        | 6-32 x 5/8" SCREW        |
| 9        | NEOPRENE RIVET NUT 6-32  |
| 1        | THIN TRIM                |
| 4        | DRILL TEMPLATES          |
| 1        | PRODUCT WARNING CARD     |
| 1        | INSTALLATION SHEET       |

**⚠ WARNING**

This product contains high intensity LED devices. To prevent eye damage, DO NOT stare into the light beam at close range.



## Interior Rear Lightbar Chevrolet Tahoe 2021

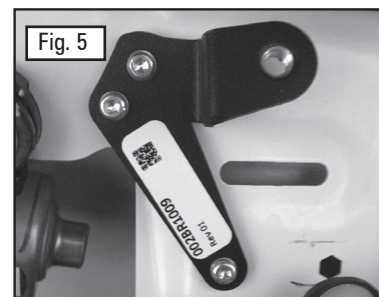
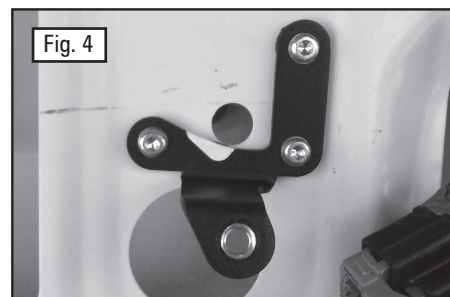
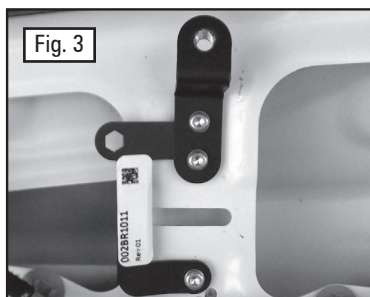
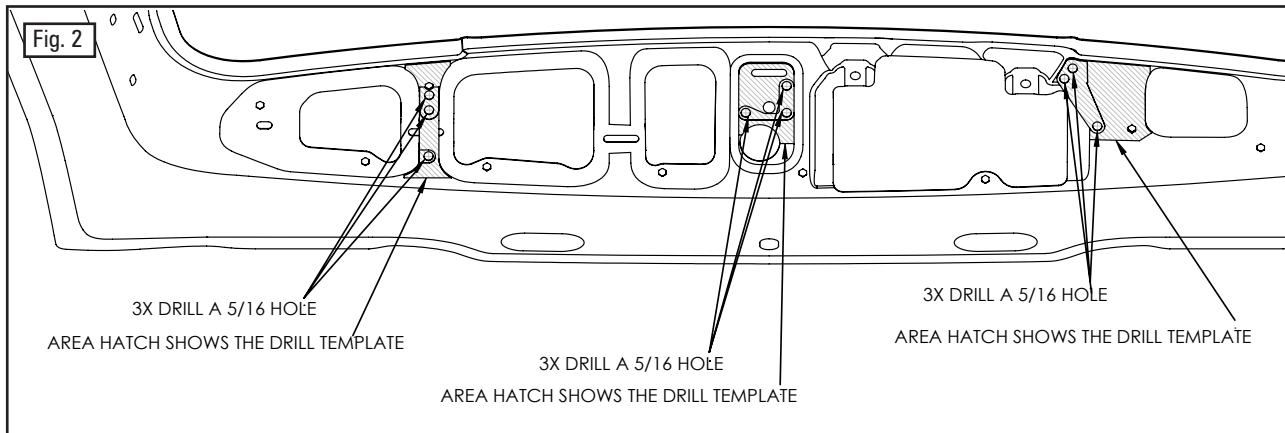
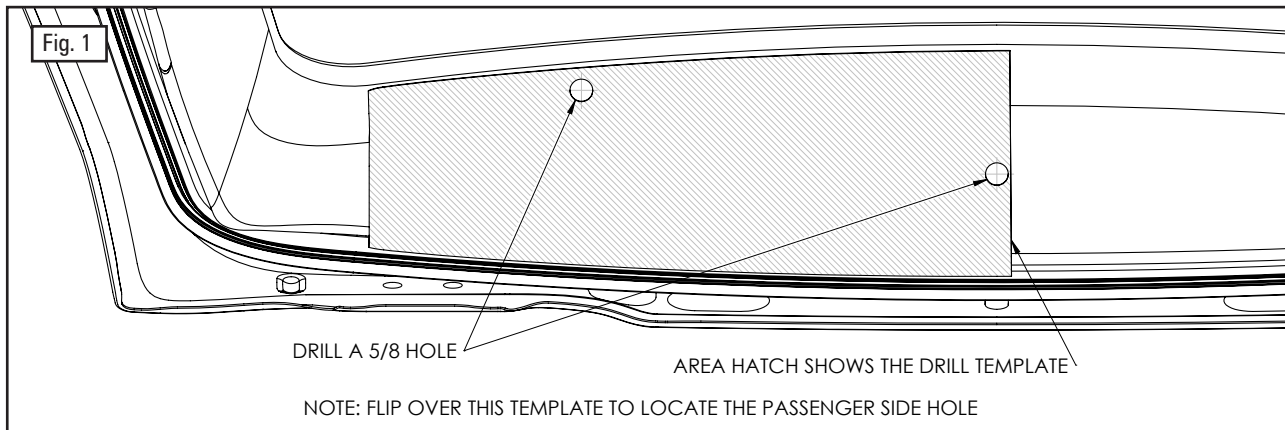

### NOTICE:

Installers and users must comply with all applicable federal, state and local laws regarding use and installation of warning devices.

*Improper use or installation may void warranty coverage.*

To review our Limited Warranty Statement & Return Policy for this or any SoundOff Signal product, visit our website at [www.soundoffsignal.com/tech-services/returns/](http://www.soundoffsignal.com/tech-services/returns/). If you have questions regarding this product, contact **Technical Services**, Monday - Friday, 8 a.m. to 5 p.m. or after hours 5 p.m. to 8 p.m. ET at 1.800.338.7337 (press #4). Questions or comments that do not require immediate attention may be emailed to [techservices@soundoffsignal.com](mailto:techservices@soundoffsignal.com).

### INSTALLATION:

1. Locate the upper cover trim panel on the tailgate. Remove the upper cover trim panel, using a plastic pry tool to assist in the upper cover trim panel removal, as needed.

**PRO TIP:** Before removing trim panel, close tailgate and open rear window.

2. Follow the instructions on the driver's side "Drill Template for Plastic Trim" to align the template with the outer edge of the removed upper cover trim panel, as seen in Fig 1. Drill a 5/8" hole at the positions noted on the drill template. Flip over the template and repeat this process on the passenger's side. The center hole will already be drilled when the template is flipped for the passenger's side.

3. Near the driver's side bracket installation location, remove the Christmas tree wire tie.

4. Install the driver's side drill template for the mounting bracket. Line up the driver's side drill template with the curvature of the tailgate frame, as seen in Fig 2 (The driver's side template is on the left, the center template is in the center, and the passenger's side template is on the right.)

**PRO TIP:** Use masking tape to line everything up.

5. Use a center punch to mark the three holes. Drill the holes using a 5/16" drill bit. Attach the driver's side bracket using the included 6-32 5/8" screws and neoprene rivet nuts. Apply a torque of 6 in-lbs to each of the three screws, as seen in Fig 3.

6. Press the removed Christmas tree wire tie into the hexagon hole in the driver's side bracket.

7. Install the center drill template and the passenger's side drill template for the mounting brackets as described in Step 4 and Step 5, above. When completed, they should appear as they do in Fig 4 and Fig 5.

8. Re-install the upper trim panel.

**PRO TIP:** Drill a hole, or create a notch in the trim panel, to pass the lightbar wiring through.

# SoundOff Signal

1.800.338.7337 / [www.soundoffsignal.com](http://www.soundoffsignal.com)

SUPERIOR CUSTOMER RELATIONSHIPS. SMARTLY DESIGNED LIGHTING & ELECTRONIC SOLUTIONS.

nFORCE Interior Lightbar 2021 Chevrolet Tahoe REAR 1120

## Interior Rear Lightbar Chevrolet Tahoe 2021

### INSTALLATION (CONT.):

9. Install the included gasket material onto the lightbar as seen in FIG 6.
10. Install the lightbar, using the included 1/4"-20 bolts. Tighten until the lightbar is snug to the paneling and to the glass. Do not over-tighten!

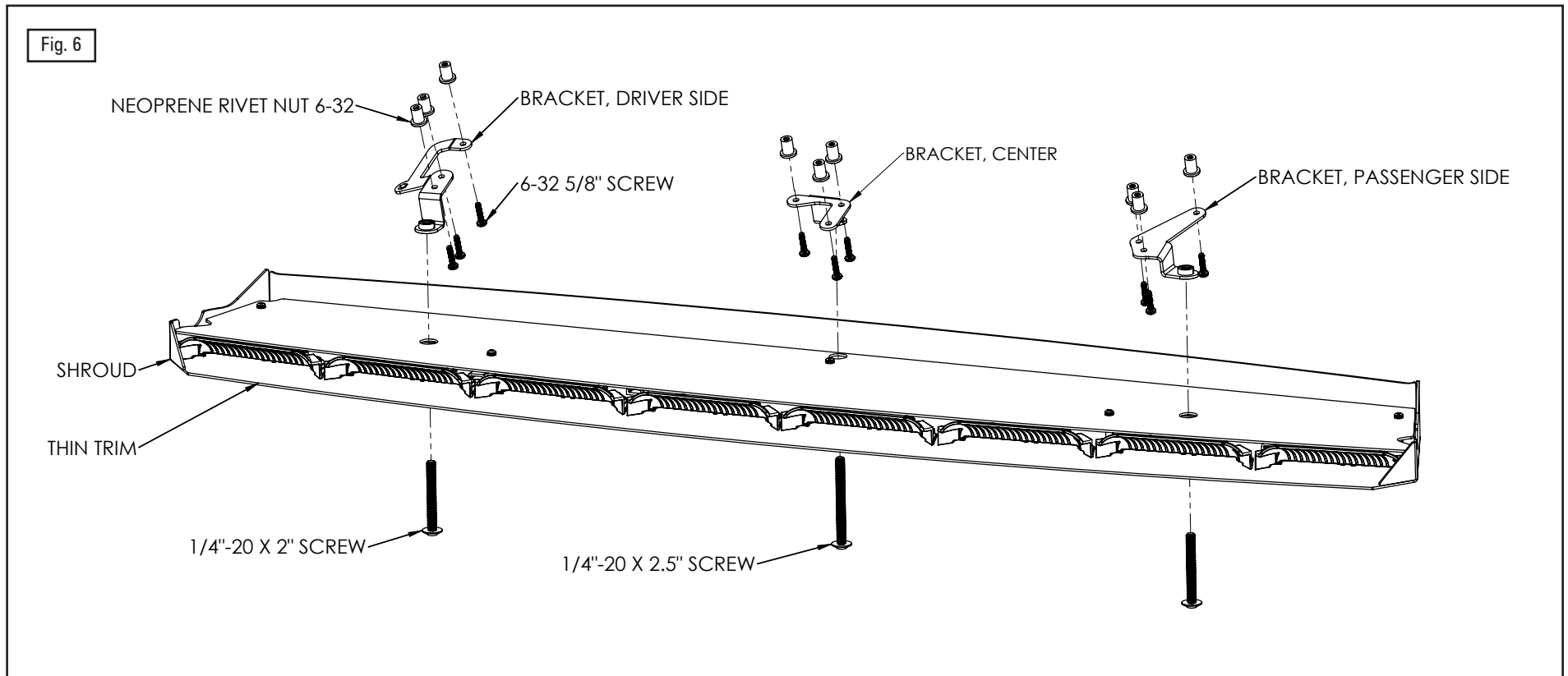

#### NOTICE:

Installers and users must comply with all applicable federal, state and local laws regarding use and installation of warning devices.

*Improper use or installation may void warranty coverage.*

To review our Limited Warranty Statement & Return Policy for this or any SoundOff Signal product, visit our website at [www.soundoffsignal.com/tech-services/returns/](http://www.soundoffsignal.com/tech-services/returns/). If you have questions regarding this product, contact **Technical Services**, Monday - Friday, 8 a.m. to 5 p.m. or after hours 5 p.m. to 8 p.m. ET at 1.800.338.7337 (press #4). Questions or comments that do not require immediate attention may be emailed to [techservices@soundoffsignal.com](mailto:techservices@soundoffsignal.com).

**SoundOff  
Signal**

1.800.338.7337 / [www.soundoffsignal.com](http://www.soundoffsignal.com)

SUPERIOR CUSTOMER RELATIONSHIPS. SMARTLY DESIGNED LIGHTING & ELECTRONIC SOLUTIONS.