

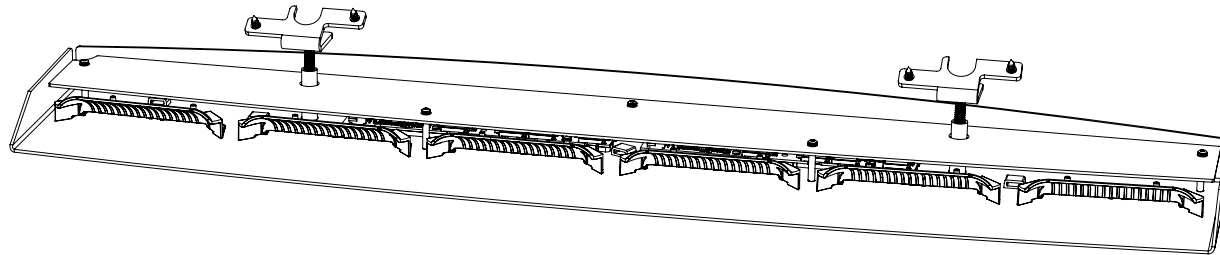

**Interior Rear Lightbar**  
2020-2021 Ford PI Utility



**⚠ WARNING**

- HIGH CURRENT interconnects must be properly terminated. Poor crimp quality can cause heat build-up and fire. Follow crimp connector manufacturer instructions.
- DO NOT install this product or route any wires in the Air Bag Deployment Zone. Refer to vehicle Owner's Manual for deployment zones.
- Do NOT use system to disconnect headlights, brake lights or other safety equipment.
- Unit may become hot to touch during normal operation.
- Failure to properly install connectors, fuses or wiring may cause vehicle failure or fire.
- Installation must only be performed by trained technician. Installer must determine vehicle wiring configuration and proper integration of system.
- Use proper wire gauge. All power wires connecting to positive (+) or negative (-) battery terminal or local chassis ground (-) must be sized to supply at least 125% of max. current and properly fused at power source.
- Install protective grommets when routing wire through firewall or metal.

**NOTICE:**

Installers and users must comply with all applicable federal, state and local laws regarding use and installation of warning devices.

*Improper use or installation may void warranty coverage.*

To review our Limited Warranty Statement & Return Policy for this or any SoundOff Signal product, visit our website at [www.soundoffsignal.com/tech-services/returns/](http://www.soundoffsignal.com/tech-services/returns/). If you have questions regarding this product, contact **Technical Services**, Monday - Friday, 8 a.m. to 5 p.m. or after hours 5 p.m. to 8 p.m. ET at **1.800.338.7337** (press #4). Questions or comments that do not require immediate attention may be emailed to [techservices@soundoffsignal.com](mailto:techservices@soundoffsignal.com).



1.800.338.7337 / [www.soundoffsignal.com](http://www.soundoffsignal.com)

**INTRODUCTION:**

**Design highlights for 2020 Ford PI Utility nFORCE® Lightbar for Rear Interior:**

- 6 module, full shroud design
- Top cover incorporated into this rear interior lightbar design, for improved look and installation
- Improved wire management incorporated into design
- Powder coat is smoother, less textured, than traditional SoundOff Signal® interior lightbars

**CONTENTS**

QTY	COMPONENT
1	2020 FORD UTILITY REAR INTERIOR LIGHTBAR SHROUD
2	2020 FORD UTILITY REAR INTERIOR LIGHTBAR BRACKET
2	2020 FORD UTILITY REAR INTERIOR LIGHTBAR STANDOFF
2	1/4" - 20 THREAD 2.5" LONG BUTTON SCREW
4	#8 X .50 TRUSS HEAD PHILLIPS SHEET METAL SCREW
1	PLASTIC FASCIA DRILL TEMPLATE
1	DRIVER SIDE DRILL TEMPLATE
1	PASSENGER SIDE DRILL TEMPLATE
1	PRODUCT WARNING CARD
1	INSTALLATION INSTRUCTION SHEET

**⚠ WARNING**

This product contains high intensity LED devices. To prevent eye damage, DO NOT stare into the light beam at close range.

SUPERIOR CUSTOMER RELATIONSHIPS. SMARTLY DESIGNED LIGHTING & ELECTRONIC SOLUTIONS.

## Interior Rear Lightbar 2020-2021 Ford PI Utility

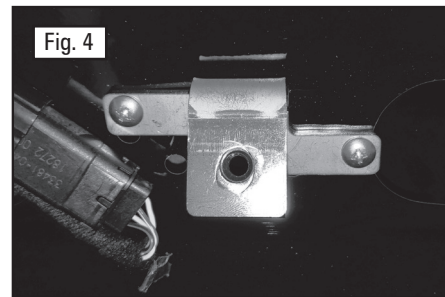
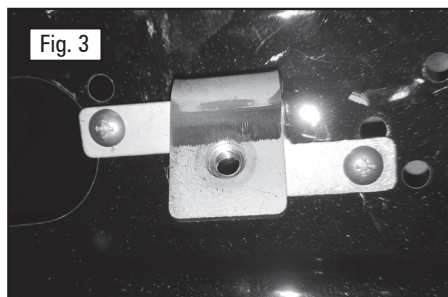
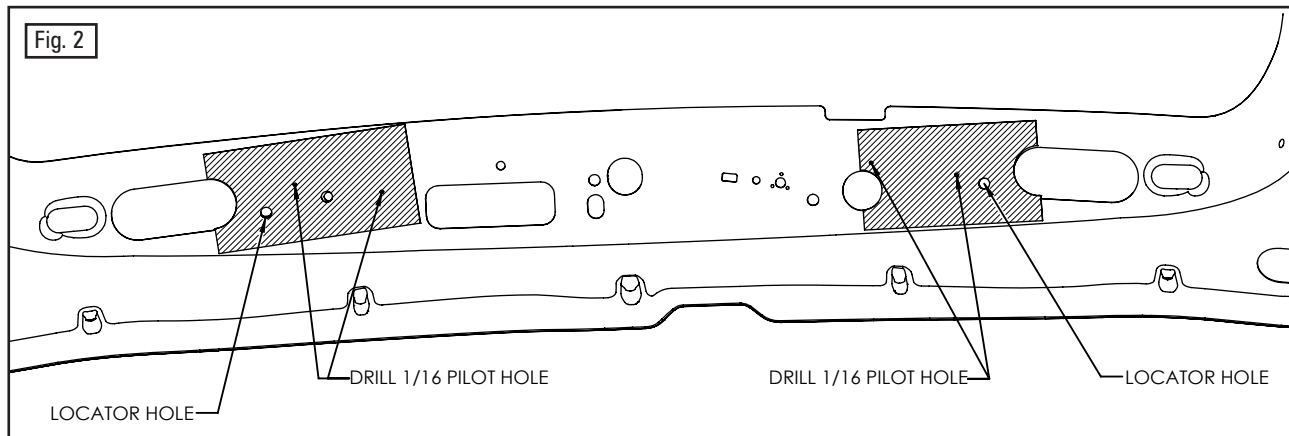
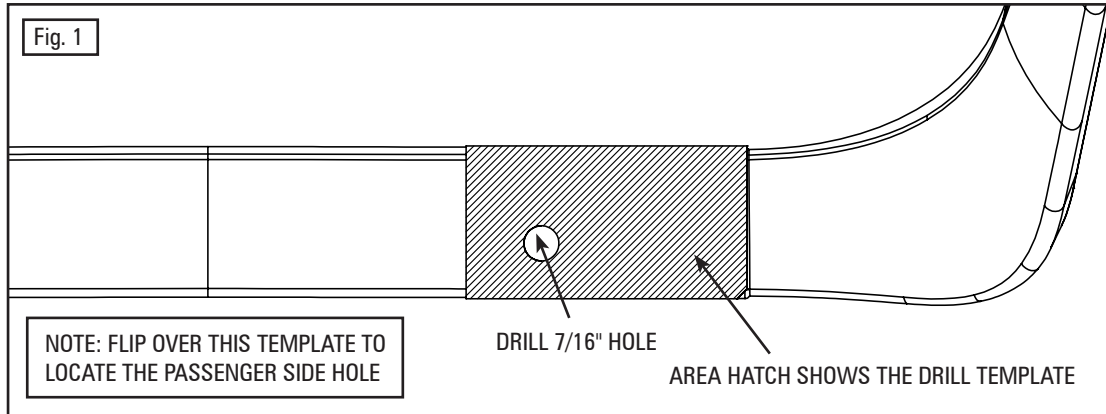

### INSTALLATION:

1. On the vehicle towards the top of the rear hatch, there is a rectangular plastic fascia. For reference, place a piece of tape, or marker, on the edge of the fascia that farthest from the glass. Then remove the fascia.
2. Place the Plastic Fascia Drill Template, shown in Fig 1, onto the rectangular plastic fascia removed in the Step 1. To position the template, face the DOWN side of the template, as indicated in Fig. 1, towards the piece of tape, or marker, you placed on the edge of the fascia in Step 1. The OUT side of the template, as indicated in Fig. 1, will face towards the outside edge of the fascia. Tape down the template.

**NOTE: The cut corner will face down on the rectangular plastic fascia.**

3. Drill a 7/16 hole, as indicated in Fig. 1.
4. Remove Plastic Fascia Drill Template and repeat Step 2 and Step 3 for the driver's side.
5. On the passenger side of the vehicle's rear hatch, you will see punched sheet metal holes. Line up the holes in the Passenger Side Drill Template with these holes. Tape down the drill template, as seen in Fig. 2.
6. Use a 1/16" drill bit to drill the pilot holes for the DRILL HOLES indicated in Fig. 2.
7. On the driver's side of the vehicle's rear hatch, you will see more punched sheet metal holes. Line up the holes in the Driver Side Drill Template with these holes. Tape down the drill template, as seen if Fig. 2.
8. Use a 1/16" drill bit to drill the pilot holes for the DRILL HOLES indicated in Fig. 2.
9. Using the 4 sheet metal screws, mount the 2 stainless steel brackets to the rear hatch using the pilot holes created in Steps 6 & 8. The brackets should be fully seated, as seen in Fig. 3 and 4.

**PRO TIP: The recommended torque specification for sheet metal screws is 10 in-lb.**

10. Re-install the rectangular plastic fascia removed in Step 1. Reference original Ford® instructions for re-installation help, as needed.

### NOTICE:

Installers and users must comply with all applicable federal, state and local laws regarding use and installation of warning devices.

*Improper use or installation may void warranty coverage.*

To review our Limited Warranty Statement & Return Policy for this or any SoundOff Signal product, visit our website at [www.soundoffsignal.com/tech-services/returns/](http://www.soundoffsignal.com/tech-services/returns/). If you have questions regarding this product, contact **Technical Services**, Monday - Friday, 8 a.m. to 5 p.m. or after hours 5 p.m. to 8 p.m. ET at 1.800.338.7337 (press #4). Questions or comments that do not require immediate attention may be emailed to [techservices@soundoffsignal.com](mailto:techservices@soundoffsignal.com).

**SoundOff  
Signal**

1.800.338.7337 / [www.soundoffsignal.com](http://www.soundoffsignal.com)

SUPERIOR CUSTOMER RELATIONSHIPS. SMARTLY DESIGNED LIGHTING & ELECTRONIC SOLUTIONS.

nFORCE Interior Lightbar 2020-2021 Ford Utility REAR 0221

**Interior Rear Lightbar**  
2020 Ford PI Utility

**INSTALLATION (CONT.):**

11. Connect all wiring to the nFORCE® Rear Interior Lightbar.
12. Once all of the wires are connected, insert the shroud standoffs and button screws into the lightbar. Thread screws in then tighten until torque specification, or until lightbar is fully seated.

**PRO TIP:** The recommended torque specification for the button screws is 15 in-lb.

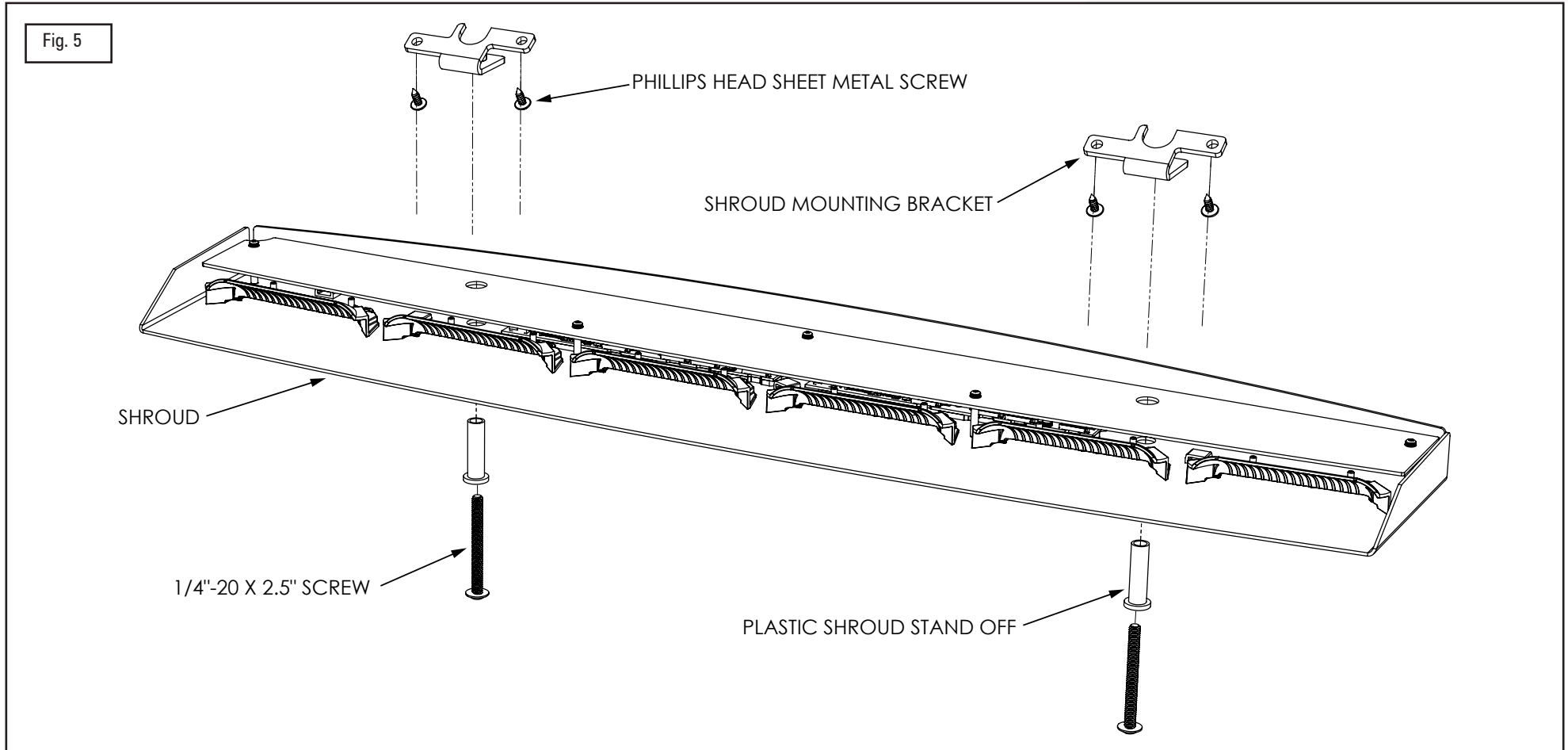

**NOTICE:**

Installers and users must comply with all applicable federal, state and local laws regarding use and installation of warning devices.

*Improper use or installation may void warranty coverage.*

To review our Limited Warranty Statement & Return Policy for this or any SoundOff Signal product, visit our website at [www.soundoffsignal.com/tech-services/returns/](http://www.soundoffsignal.com/tech-services/returns/).  
If you have questions regarding this product, contact **Technical Services**, Monday - Friday, 8 a.m. to 5 p.m. or after hours 5 p.m. to 8 p.m. ET at 1.800.338.7337 (press #4).  
Questions or comments that do not require immediate attention may be emailed to [techservices@soundoffsignal.com](mailto:techservices@soundoffsignal.com).

**SoundOff  
Signal**

1.800.338.7337 / [www.soundoffsignal.com](http://www.soundoffsignal.com)

SUPERIOR CUSTOMER RELATIONSHIPS. SMARTLY DESIGNED LIGHTING & ELECTRONIC SOLUTIONS.

nFORCE Interior Lightbar 2020-2021 Ford Utility REAR 0221