

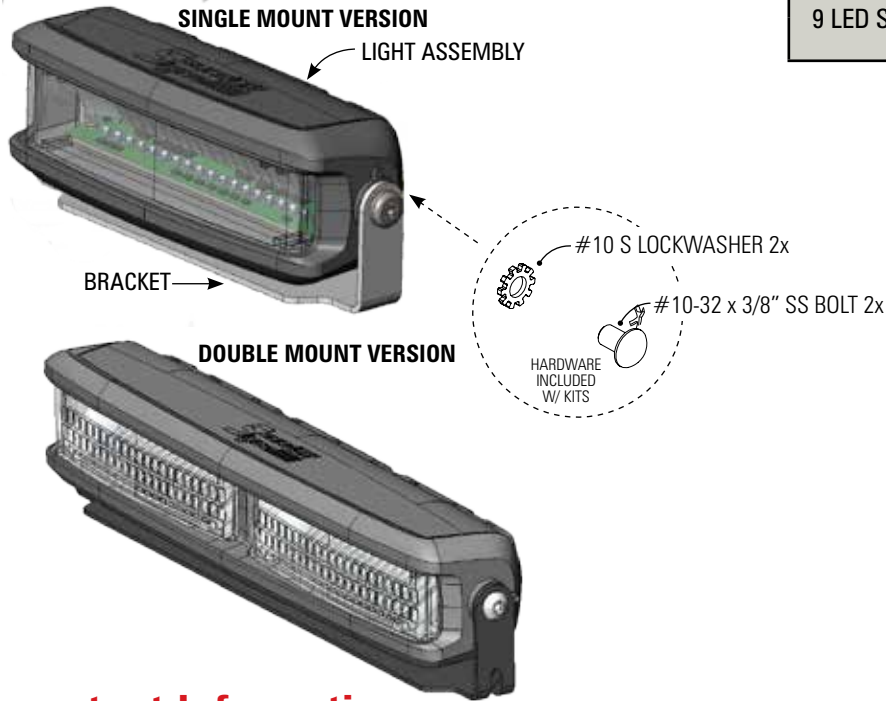

ECE-R65 CLASS 2 CERTIFIED DECK/ GRILLE MOUNT

- ENFSGE(xx) - SINGLE DECK/GRILLE
- ENFDGE(xx) - DUAL DECK/GRILLE
- ENFSLSGE - SINGLE DECK/GRILLE
- ENFSLDGE - DUAL DECK/GRILLE



Important Information:

- Warning devices are strictly regulated and governed by Federal, State and Municipal ordinances. These devices shall be used ONLY on approved vehicles. It is the sole responsibility of the user of these devices to ensure compliance.
- DO NOT connect this device to a strobe power supply. This product is self-contained and does not require an external power supply.



Warning devices are strictly regulated and governed by Federal, State and Municipal ordinances. These devices shall be used ONLY on approved vehicles. It is the sole responsibility of the user of these devices to ensure compliance.

To review our Limited Warranty Statement & Return Policy for this or any SoundOff Signal product, visit our website at www.soundoffsignal.com/sales-support. If you have questions regarding this product, contact Technical Services, Monday - Friday, 8 a.m. to 5 p.m. at 1.800338.7337 (press #4 to skip the automated message). Questions or comments that do not require immediate attention may be emailed to techservices@soundoffsignal.com.

TECHNICAL SPECIFICATIONS	
DECK/ GRILL MOUNT NEXUS	
Single Mount Dimensions:	5.0"L x 1.88"H x 1.82"D
Double Mount Dimensions:	9.50"L x 1.88"H x 1.82"D
Input Voltage:	10 - 30 Vdc per module
CURRENT CONSUMPTION PER MODULE	
9 LED Single Color	<1.6A @ 12.8 Vdc
	<0.9A @ 25.6 Vdc

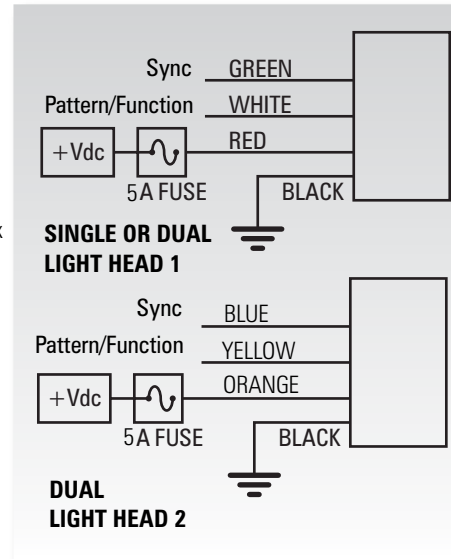

IMPORTANT INFORMATION:

INSTALLATION: DECK/GRILLE MOUNT

- 1) Establish a flat position on the vehicle. Drill 3/16" holes in the center of the mounting locations. Note: 2 bolts are desired for the single mount and 4 bolts for the double mount attachments (not included with hardware kit). See page 2 for hole spacing.

INFORMATION FOR NEXUS SECONDARY:

WIRE HOOK-UP TABLE		
WIRE COLOR:	LIGHT HEAD	FUNCTION:
RED	1	Power
BLACK	1	Ground
**GREEN	1	Sync2 *
WHITE	1	To Ground: Pattern Select/ Setup
		By Night Feature See page 2
ORANGE	2	Power
BLACK	2	Ground
BLUE	2	Sync 2*
YELLOW	2	To Ground: Pattern Select/ Setup
		By Night Feature See page 2

** To sync multiple Single NForce™ lights, connect the Green wires from each light together. *To sync individual Dual nForce lights connect the Green & Blue wires together.

* Will NOT work w/ other sync products such as Ghost, LED3, & Interceptor.



PATTERNS	
NUMBER	NAME
1	SINGLE
2	DOUBLE
3	TRIPLE

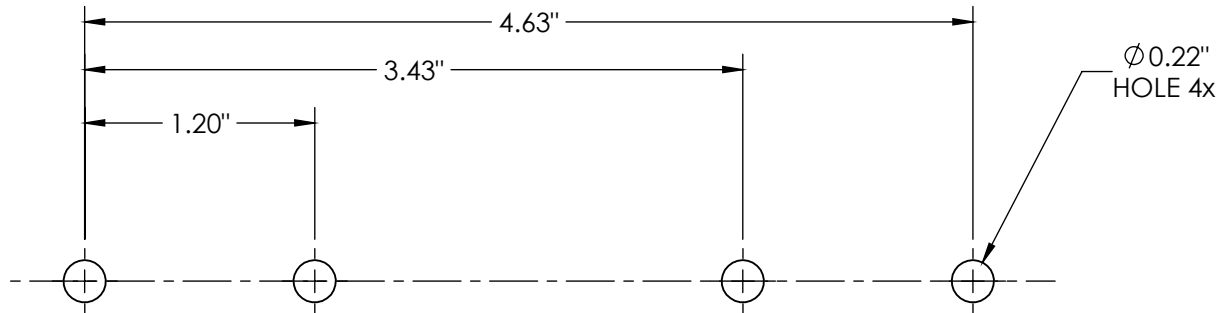

DOUBLE MOUNT DECK/ GRILLE TEMPLATE

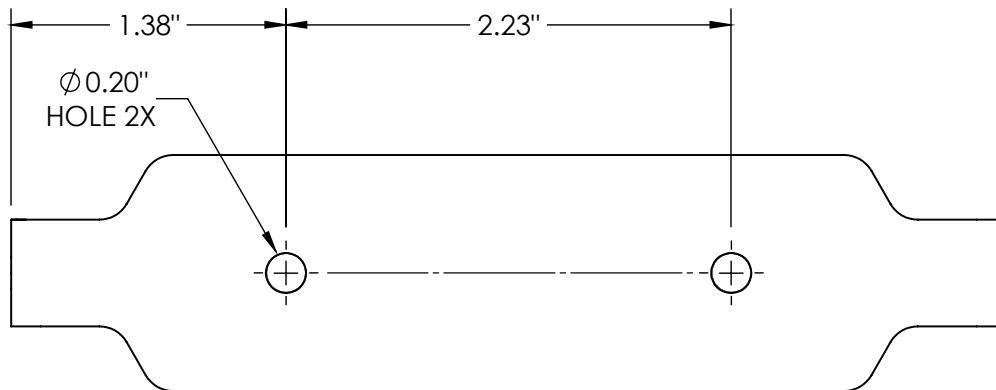

DECK/ GRILLE TEMPLATE



1.800.338.7337 / www.soundoffsignal.com

PATTERN SELECT & SYNC CONFIGURATION INSTRUCTIONS

Connecting the WHITE wire to power will allow you to use the **By Night** feature on your Single Nexus Secondary Light. Connecting the YELLOW wire to power will allow you to use the **By Night** feature on your Dual Nexus Secondary Light.

BY NIGHT FEATURE:

- Reduced intensity for night time use
- Apply power to white wire for single lights. Apply power to white and yellow wire for dual lights.

BY DAY FEATURE:

- Standard intensity for day time use
- Leave white wire floating for single lights. Leave yellow wire floating for dual lights.

SETUP LIGHTS:

- To sync multiple Single nForce lights, connect the green wires together. To sync multiple Dual nForce lights, connect the blue and green wires together.

Simultaneous or Alternate Function

- 1 or 2. The modules will flash simultaneously if they are set to the same number. The modules will have an alternate flash if set to different numbers.*

Touching the WHITE wire to the ground will allow you to change various setting on a SINGLE or first DUAL nForce Light.

Touching the YELLOW wire to the ground will allow you to change various setting on the second DUAL nForce Light.

SETUP TABLE

SECONDS		USER INTERFACE	
FROM	TO	VISUAL FEEDBACK	ACTION TAKEN
0	1	STEADY-HIGH (60%)	FORWARD ONE PATTERN
1	2	STEADY-LOW (30%)	BACKWARD ONE PATTERN
2	3	OFF	NA
3	4	STEADY - HIGH (60%)	SIMULTANEOUS OR ALTERNATE
4	5	STEADY - LOW (30%)	NA
5	6	OFF	RESET TO PATTERN 1

If held longer than 6 seconds, the light will go back to flashing the current pattern and no action will be taken.