

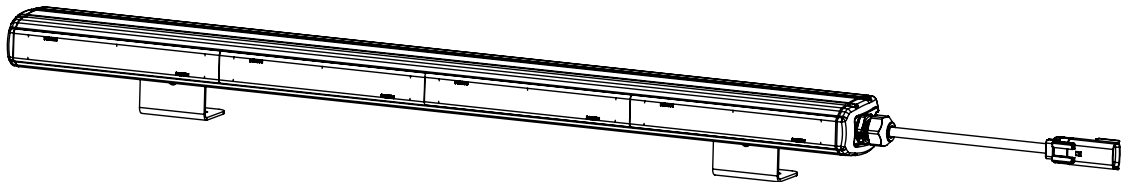

INSTALLATION INSTRUCTIONS
mPOWER® Traffic Controller
EMPTCxxxxx



IMPORTANT NOTICE TO INSTALLER:

- Make sure to read and understand all instructions and warnings before proceeding with the installation of this product. Ensure that the manual and any warning cards are delivered to the end user of this equipment. Proper installation of the lightbar requires the installer to have a thorough knowledge of automotive electronics, systems, and procedures.
- Lightbars provide an essential function of an effective visual warning system. The use of the lightbar does not insure that all drivers can or will abide by or react to an emergency warning signal, especially at high rates of speeds or long distances. The operator of the vehicle must never take the right of way for granted and it is the operator's responsibility to proceed safely.
- The effectiveness of the lightbar is highly dependant on the correct mounting and wiring. The installer must read and follow the manufacturer's installation instructions and warnings in the manual. The vehicle operator should verify daily that the lightbar is securely fastened to the vehicle and properly functioning before operating vehicle.
- The lightbar is intended for use by authorized personnel only. It is the user's responsibility to ensure they understand and operate the emergency warning devices in compliance with the applicable city, state and federal laws and regulations. SoundOff Signal assumes no liability for any loss resulting from the use of this warning device.

WARNING

- This product contains high intensity LED devices to prevent eye damage, DO NOT stare into the light beam at close range.

IMPORTANT INFORMATION:

- To view the full Software Revision History click the  in the lower left hand corner of the SoundOff Central Lightbar application.
- Warning devices are strictly regulated and governed by Federal, State and Municipal ordinances. These devices shall be used ONLY on approved vehicles. It is the sole responsibility of the user of these devices to ensure compliance.
- DO NOT install this product or route any wires in the Air Bag Deployment Zone. Refer to your vehicle Owner's Manual for the location of any air bag deployment zones.
- DO NOT connect this device to a strobe power supply. This product is self-contained and does not require an external power supply.

WARNING

- Route wires only in locations that are not subjected to potential wear. Make sure to avoid routing wires in the deployment area of your airbag. Refer to your vehicle's owner's manual for airbag deployment zone.
- All customer supplied power wires connecting to the positive (+) or negative (-) battery terminal or local chassis ground (-) must be sized to supply at least 125% of the maximum current and properly fused at the power source with appropriately rated fuse.

NOTICE:

- Installers and users must comply with all applicable federal, state and local laws regarding use and installation of warning devices.
- Improper use or installation may void warranty coverage.
- To review our Limited Warranty Statement & Return Policy for this or any SoundOff Signal product, visit our website at www.soundoffsignal.com/tech-services/returns/.
- If you have questions regarding this product, contact Technical Services, Monday - Friday, 8 a.m. to 5 p.m. ET at 1.800.338.7337 (press #4).
- Questions or comments that do not require immediate attention may be emailed to techgroup@soundoffsignal.com.

Table of Contents

Components/Contents	4
Technical Specifications	4
Electrical Installation	5
Flash Patterns	6
Arrow Patterns	11
Control Harness	12
Vehicle Installation	14
mPower® Troubleshooting	15
Connection of Breakout Box to SoundOff Signal Sirens	16
Replacement Parts & Accesories	18
Warranty & Return Goods Procedure	19
Notes	20

CONTENTS	
QTY	COMPONENT
1	mPower® Traffic Controller built to your specifications
MOUNTING HARDWARE	
2	4 or 6 mod assembly
3	8 mod assembly
4	8 split or 10 mod assembly

OPTIONAL EQUIPMENT		
COMPONENTS	Breakout Box LIN (Standard) Qty.	Breakout Box CAN System Qty.
Universal BOB (LIN)	1	0
Universal BOB (CAN)	0	1
24 Pin Harness	1	1
4 Pin Harness	1	1
5 Pin Harness	0	1

*Kits will vary with each Traffic Controller depending on vehicle specified on order form.

TECHNICAL SPECIFICATIONS		
INPUT VOLTAGE RANGE	10-32Vdc	
OPERATING TEMPERATURE	-40°C to +65°C (-40°F to +149°F)	
ELECTRICAL PROTECTION	Reverse Polarity Over-Voltage	Transient Voltage High-Temperature Thermal Fold-back
MATERIAL	Aluminum Alloy Housing, Silicone Lens	
STANDBY CURRENT(Per Module)	IGNITION ON: 0.20 Amps IGNITION OFF: 0.0002 Amps	
STANDBY POWER(Per Module)	IGNITION ON: 0.13 Watts IGNITION OFF: 0.03 Watts	
CURRENT / POWER(Per Module)	Current Draw	Power Consumption
@12Vdc	Flashing	1.14 Amps
	Peak	1.9 Amps
POWER CABLE	3ft - 16 AWG wires 15ft - 14 AWG wires 25ft - 12 AWG wires	(+) Red (-) Black (Data) Green
OVERALL DIMENSIONS	1.9H X 2.47" D X Chosen length	
NUMBER OF MODULES	TOTAL LENGTH	
4	26.0"	
6	39.0"	
8	52.0"	
10	64.0"	

Unpack Lightbar

1. Remove Traffic Controller from box and packaging.
2. Save packaging for later shipping.
3. Check components/contents.
4. Please reference these instructions for proper wiring and installation.

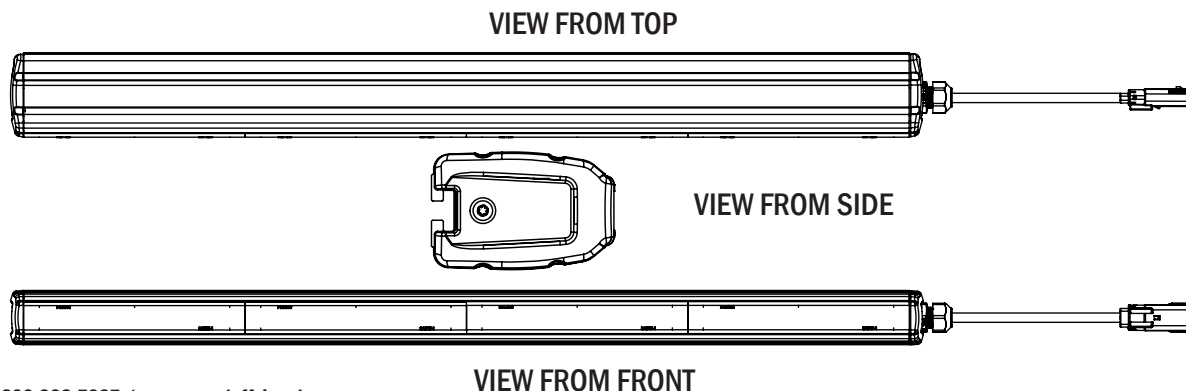

ELECTRICAL INSTALLATION

Featured Highlights & Terminology:

Cruise & Cruise 2 Mode: Allows the user to program any light group(s) to "Glow" when this feature is activated. For dual/tri color bars, the color for each light group is selectable.

Directional Arrow Built-in: The directional controller is built-in arrow patterns for each of the 3 modes (left arrow, right arrow, and center out arrow) and the color is selectable for dual/tri color bars

Scene Light Mode: Allows the user to program any Light Head Group(s) to turn on steady when this feature is activated to provide additional scene lighting. The activation of this input also activates the Takedown function

Stop / Tail / Turn Mode: Allows the user to program any Light Head Group(s) to turn operate in 2 levels of intensity for tail and stop/turn functions.

Low Power Mode: Operates lighting at reduced intensity.

Power Cables:

1. Route Traffic Controller power cables as close to vehicles power source (battery) as possible.
2. Install a maximum of 25Amp Fuse(8 & 10 module), 15AMP Fuse(4 & 6 module) (customer supplied) to the end of the RED wire of the Traffic Controller Power Cable.
 - a. Remove the fuse before connecting any wires to the battery.
 - b. DO NOT USE CIRCUIT BREAKER OR FUSIBLE LINK.
3. Connect the other end of the Fuse to the POSITIVE (+) terminal of the battery.
 - a. Do NOT use any more than 2ft of wire between the battery terminal and the fuse and ensure the wire is protected and secured from being cut into; this is non-fused wire.
4. Connect the BLACK wire to the factory chassis ground right next to the battery.

Control (Data) Cable:

1. Route Traffic Controller Control Cable to the location where all controlling equipment will be, i.e. switch box, center console area.
2. Locate the Breakout Box in the same area to connect jumpers from the switching equipment to the breakout box.
3. Refer to breakout box hookup table on page 11.

NOTE: Breakout Box must be mounted inside vehicle where it will not get wet.

Initial Power up Test:

1. Connect Green wire from Traffic Controller to Green LIN 1 (Front/Left mounted bars only), or Green/White LINE 2 (Rear/Right mounted bars only) of the 4-pin Breakout Box Harness as shown on page 11.
2. Connect the red and the black wire from Traffic Controller to red and black wire of the 4-pin Breakout Box Harness, as shown on Page 11.
3. Observe the GREEN Data Link indicator LED on the Breakout Box; the Green LED will be ON showing power is connected.
4. The Red indicator LED on the breakout box will be steady ON whenever any of the input wires, with the Ignition wire connected, are active or data is received from a siren.

Low Power (Standby) Mode (reduced standby current)

If there is no input to the breakout box the Traffic Controller will go into a "standby" mode. The standby mode is a low power mode that is used to extend the life of your battery. The Traffic Controller will awaken from the standby mode if any input is activated on the breakout box.

ELECTRICAL INSTALLATION (CONT.)

*fpm=Flashes per Minute

**fps=Flashes per Second

FLASH PATTERNS

#	Name	SAE Compliant Timing	ECE Compliant Timing	California Title 13 Compliant Timing	Color	Sequence	fpm	fps
SC1	Random 1	Yes	No	No	#1	Variable	-	-
SN2	Random 2	No	No	No	#1	Variable	-	-
SC3	Quint	Yes	No	No	#1	Alternating	70	1.2
SC4	Quad 2	Yes	No	No	#1	Variable	-	-
SC5	Q-Switch	Yes	No	No	#1	Variable	-	-
SC6	Double	Yes	No	No	#1	Alternating	115	1.9
SC7	Power Pulse	Yes	No	No	#1	Alternating	180	3
SC8	Road Runner	Yes	No	Yes	#1	Alternating	115	1.9
SC9	Slow Runner	Yes	No	Yes	#1	Alternating	70	1.2
SN10	Warp	No	No	No	#1	Alternating	350	5.8
SN11	Inter-Cycle	No	No	No	#1	Alternating	-	-
SN12	Warp 1-2-3	No	No	No	#1	Alternating	-	-
SC13	E-Single	Yes	Yes	No	#1	Alternating	125	2.1
SC14	E-Double	Yes	Yes	No	#1	Alternating	125	2.1
SC15	E-Triple	Yes	Yes	No	#1	Alternating	125	2.1
SC16	E-Single Sim	Yes	Yes	No	#1	Simultaneous	125	2.1
SC17	E-Double Sim	Yes	Yes	No	#1	Simultaneous	125	2.1
SN18	Super Slow Runner	No	No	No	#1	Alternating	55	0.9
SC19	Quint Simultaneous	Yes	No	No	#1	Simultaneous	70	1.2
SC20	Road Runner Simultaneous	Yes	No	No	#1	Simultaneous	114	1.9
SC21	Quint Pass/Steady Driver	Yes	No	No	#1	-	70	1.2
SC22	Road Runner Pass/Steady Driver	Yes	No	No	#1	-	114	1.9
SC23	Quint 2	Yes	No	No	#1	-	70	1.2
SN24	Warp 2	No	No	No	#1	-	350	5.8
SN25	Inter-Cycle 2	No	No	No	#1	-	-	-
SN26	Flicker Brake	No	No	No	#1	-	-	-
SN27	Flicker Cruise	No	No	No	#1	-	-	-
SN28	Steady	No	No	No	#1	-	-	-
SN29	Manifesto	No	No	No	#1	-	-	-
SN30	Power Evert	No	No	No	#1	-	-	-
SN31	Dazzle	No	No	No	#1	-	-	-
SN32	Quiver	No	No	No	#1	-	-	-

NOTE: Takedown light patterns are limited to pattern #1 – 25

ELECTRICAL INSTALLATION (CONT.)

*fpm=Flashes per Minute

**fps=Flashes per Second

FLASH PATTERNS

#	Name	SAE Compliant Timing	ECE Compliant Timing	California Title 13 Compliant Timing	Color	Sequence	fpm	fps
SN33	Power Sway	No	No	No	#1	-	-	-
SN34	Evert	No	No	No	#1	-	-	-
SN35	Alternating Rapid Flash	No	No	No	#1	-	-	-
SN36	Swift Impact	No	No	No	#1	-	-	-
SN37	Tango	No	No	No	#1	-	-	-
SN38	Tremble	No	No	No	#1	-	-	-
SN39	Shake	No	No	No	#1	-	-	-
SN40	Evolver	No	No	No	#1	Simultaneous	-	-
SN41	Corner Sweep	No	No	No	#1	-	-	-
SN42	Corner Sweep Slow	No	No	No	#1	-	-	-
SN43	Full/Sweep	No	No	No	#1	-	-	-
SN44	Full/Sweep Slow	No	No	No	#1	-	-	-
SN45	Center Sweep	No	No	No	#1	-	-	-
SN46	Center Sweep Slow	No	No	No	#1	-	-	-
SN47	Orbit	No	No	No	#1	-	-	-
SN48	Orbit Slow	No	No	No	#1	-	-	-
SN49	Double Orbit	No	No	No	#1	-	-	-
SN50	Slow Double Orbit	No	No	No	#1	-	-	-
SN51	Retrograde Orbit	No	No	No	#1	-	-	-
SN52	Slow Retrograde Orbit	No	No	No	#1	-	-	-
SN53	Progressive Alternate	No	No	No	#1	-	-	-
SN54	Recurrent	No	No	No	#1	Simultaneous	-	-
SN55	E-Scroll	No	Yes	No	#1	Alternating	-	-
SN56	ECE-Single - Aura	No	No	No	#1	Alternating	-	-
SN57	ECE-Single - Aura II	No	No	No	#1	Alternating	-	-
DC1	Random Dual #1	Yes	No	No	#1/2	Variable	-	-
DN2	Random Dual #2	No	No	No	#1/2	Variable	-	-
DC3	Quint Dual	Yes	No	No	#1/2	Alternating	70	1.2
DC4	Quad 2 Dual	Yes	No	No	#1/2	Variable	-	-
DC5	Q-Switch Dual	Yes	No	No	#1/2	Variable	-	-
DC6	Double Dual	Yes	No	No	#1/2	Alternating	115	1.9
DC7	Power Pulse Dual	Yes	No	No	#1/2	Alternating	180	3
DC8	Road Runner Dual	Yes	No	Yes	#1/2	Alternating	115	1.9
DC9	Slow Runner Dual	Yes	No	Yes	#1/2	Alternating	70	1.2
DN10	Warp Dual	No	No	No	#1/2	Alternating	350	5.8
DN11	Inter-Cycle Dual	No	No	No	#1/2	Alternating	-	-
DN12	Warp 1-2-3 Dual	No	No	No	#1/2	Alternating	-	-
DN13	Pattern #1 Dual	No	No	No	#1/2	Variable	-	-
DN14	Pattern #2 Dual	No	No	No	#1/2	Variable	-	-

ELECTRICAL INSTALLATION (CONT.)

*fpm=Flashes per Minute

**fps=Flashes per Second

FLASH PATTERNS

#	Name	SAE Compliant Timing	ECE Compliant Timing	California Title 13 Compliant Timing	Color	Sequence	fpm	fps
DN15	Impact Dual	No	No	No	#1/2	Variable	-	-
DN16	Explosion Dual	No	No	No	#1/2	Variable	-	-
DC17	Quint Simultaneous Dual	Yes	No	No	#1/2	Simultaneous	70	1.2
DC18	Road Runner Sim. Dual	Yes	No	No	#1/2	Simultaneous	114	1.9
DC19	Quint 2 Dual	Yes	No	No	#1/2	-	70	1.2
DN20	Warp 2 Dual	No	No	No	#1/2	-	350	5.8
DN21	Inter-Cycle 2 Dual	No	No	No	#1/2	-	-	-
DN22	Super Slow Runner Dual	No	No	No	#1/2	-	-	-
DN23	Flicker Cruise Dual	No	No	No	#1/2	-	-	-
DN24	Manifesto Dual	No	No	No	#1/2	-	-	-
DN25	Power Evert Dual	No	No	No	#1/2	-	-	-
DN26	Dazzle Dual	No	No	No	#1/2	-	-	-
DN27	Quiver Dual	No	No	No	#1/2	-	-	-
DN28	Power Sway Dual	No	No	No	#1/2	-	-	-
DN29	Evert Dual	No	No	No	#1/2	-	-	-
DN30	Alternating Rapid Flash Dual	No	No	No	#1/2	-	-	-
DN31	Swift Impact Dual	No	No	No	#1/2	-	-	-
DN32	Tango Dual	No	No	No	#1/2	-	-	-
DN33	Tremble Dual	No	No	No	#1/2	-	-	-
DN34	Shake Dual	No	No	No	#1/2	-	-	-
DN35	Evolver Dual	No	No	No	#1/2	Simultaneous	-	-
DN36	Corner Sweep Dual	No	No	No	#1/2	-	-	-
DN37	Corner Sweep Slow Dual	No	No	No	#1/2	-	-	-
DN38	Full/Sweep Dual	No	No	No	#1/2	-	-	-
DN39	Full/Sweep Slow Dual	No	No	No	#1/2	-	-	-
DN40	Center Sweep Dual	No	No	No	#1/2	-	-	-
DN41	Center Sweep Slow Dual	No	No	No	#1/2	-	-	-
DN42	Orbit Dual	No	No	No	#1/2	-	-	-
DN43	Orbit Slow Dual	No	No	No	#1/2	-	-	-
DN44	Double Orbit Dual	No	No	No	#1/2	-	-	-
DN45	Slow Double Orbit Dual	No	No	No	#1/2	-	-	-
DN46	Retrograde Orbit Dual	No	No	No	#1/2	-	-	-
DN47	Slow Retrograde Orbit Dual	No	No	No	#1/2	-	-	-
DN48	Progressive Alternate Dual	No	No	No	#1/2	-	-	-
DN49	Recurrent Dual		No	No	#1/2	Simultaneous	-	-
DN50	E-Scroll Dual	No	Yes	No	#1/2	Alternating	-	-
DN51	Road Runner Dual - Aura	No	No	No	#1/2	Alternating	-	-
DN52	Road Runner Dual - Aura II	No	No	No	#1/2	Alternating	-	-
DN53	Slow Runner Dual - Aura	No	No	No	#1/2	Alternating	-	-

ELECTRICAL INSTALLATION (CONT.)

*fpm=Flashes per Minute

**fps=Flashes per Second

FLASH PATTERNS

#	Name	SAE Compliant Timing	ECE Compliant Timing	California Title 13 Compliant Timing	Color	Sequence	fpm	fps
DN54	Slow Runner Dual - Aura II	No	No	No	#1/2	Alternating	-	-
DN55	Super Slow Runner Dual - Aura	No	No	No	#1/2	Alternating	-	-
DN56	Super Slow Runner Dual - Aura II	No	No	No	#1/2	Alternating	-	-
DN57	Corner Sweep Slow Dual - Aura	No	No	No	#1/2	-	-	-
DN58	Full Sweep Slow Dual - Aura	No	No	No	#1/2	-	-	-
DN59	Center Sweep Slow Dual - Aura	No	No	No	#1/2	-	-	-
DN60	Orbit Slow Dual - Aura	No	No	No	#1/2	-	-	-
DN61	Double Orbit Slow Dual - Aura	No	No	No	#1/2	-	-	-
DN62	Retrograde Orbit Slow Dual - Aura	No	No	No	#1/2	-	-	-
DN63	Flicker Cruise alternate Dual - Aura	No	No	No	#1/2	-	-	-
TN1	Pattern 1 Tri	No	No	No	#1/2/3	Alternating	-	-
TN2	Random Tri	No	No	No	#1/2/3	Alternating	-	-
TC3	Quint Tri	Yes	No	No	#1/2/3	Alternating	70	1.2
TC4	Quad 2 Tri	Yes	No	No	#1/2/3	Alternating	-	-
TN5	Pattern 2 Tri	No	No	No	#1/2/3	-	-	-
TC6	Double Tri	Yes	No	No	#1/2/3	Alternating	115	1.9
TC7	Power Pulse Tri	Yes	No	No	#1/2/3	Alternating	180	3
TC8	Road Runner Tri	Yes	No	Yes	#1/2/3	Alternating	115	1.9
TC9	Slow Runner Tri	Yes	No	Yes	#1/2/3	Alternating	70	1.2
TN10	Warp Tri	No	No	No	#1/2/3	Alternating	350	5.8
TN11	Inter-Cycle Tri	No	No	No	#1/2/3	Alternating	-	-
TN12	Warp 1-2-3 Tri	No	No	No	#1/2/3	Alternating	-	-
TN13	Super Slow Runner Tri	No	No	No	#1/2/3	Alternating	55	0.9
TC14	Quint Simultaneous Tri	Yes	No	No	#1/2/3	Simultaneous	70	1.2
TC15	Road Runner Sim. Tri	Yes	No	No	#1/2/3	Simultaneous	114	1.9
TC16	Quint 2 Tri	Yes	No	No	#1/2/3	Alternating	70	1.2
TN17	Warp 2 Tri	No	No	No	#1/2/3	Alternating	350	5.8
TN18	Inter-Cycle 2 Tri	No	No	No	#1/2/3	Alternating	-	-
TN19	Pattern 3 Tri	No	No	No	#1/2/3	-	-	-
TN20	Flicker Cruise Tri	No	No	No	#1/2/3	-	-	-
TN21	Manifesto Tri	No	No	No	#1/2/3	-	-	-
TN22	Power Evert Tri	No	No	No	#1/2/3	-	-	-
TN23	Dazzle Tri	No	No	No	#1/2/3	-	-	-
TN24	Quiver Tri	No	No	No	#1/2/3	-	-	-
TN25	Power Sway Tri	No	No	No	#1/2/3	-	-	-
TN26	Evert Tri	No	No	No	#1/2/3	-	-	-
TN27	Alternating Rapid Flash Tri	No	No	No	#1/2/3	-	-	-
TN28	Swift Impact Tri	No	No	No	#1/2/3	-	-	-
TN29	Tango Tri	No	No	No	#1/2/3	-	-	-

ELECTRICAL INSTALLATION (CONT.)

*fpm=Flashes per Minute

**fps=Flashes per Second

FLASH PATTERNS

#	Name	SAE Compliant Timing	ECE Compliant Timing	California Title 13 Compliant Timing	Color	Sequence	fpm	fps
TN30	Tremble Tri	No	No	No	#1/2/3	-	-	-
TN31	Shake Tri	No	No	No	#1/2/3	-	-	-
TN32	Evolver Tri	No	No	No	#1/2/3	Simultaneous	-	-
TN33	Corner Sweep Tri	No	No	No	#1/2/3	-	-	-
TN34	Corner Sweep Slow Tri	No	No	No	#1/2/3	-	-	-
TN35	Full/Sweep Tri	No	No	No	#1/2/3	-	-	-
TN36	Full/Sweep Slow Tri	No	No	No	#1/2/3	-	-	-
TN37	Center Sweep Tri	No	No	No	#1/2/3	-	-	-
TN38	Center Sweep Slow Tri	No	No	No	#1/2/3	-	-	-
TN39	Orbit Tri	No	No	No	#1/2/3	-	-	-
TN40	Orbit Slow Tri	No	No	No	#1/2/3	-	-	-
TN41	Double Orbit Tri	No	No	No	#1/2/3	-	-	-
TN42	Double Orbit Slow Tri	No	No	No	#1/2/3	-	-	-
TN43	Retrograde Orbit Tri	No	No	No	#1/2/3	-	-	-
TN44	Retrograde Orbit Slow Tri	No	No	No	#1/2/3	-	-	-
TN45	Progressive Alternate Tri	No	No	No	#1/2/3	-	-	-
TN46	Recurrent Tri	No	No	No	#1/2/3	Simultaneous	-	-
TN47	E-Scroll Tri	No	Yes	No	#1/2/3	Alternating	-	-
TN48	Road Runner Tri - Aura	No	No	No	#1/2/3	Alternating	-	-
TN49	Road Runner Tri - Aura II	No	No	No	#1/2/3	Alternating	-	-
TN50	Slow Runner Tri - Aura	No	No	No	#1/2/3	Alternating	-	-
TN51	Slow Runner Tri - Aura II	No	No	No	#1/2/3	Alternating	-	-
TN52	Super Slow Runner Tri - Aura	No	No	No	#1/2/3	Alternating	-	-
TN53	Super Slow Runner Tri - Aura II	No	No	No	#1/2/3	Alternating	-	-
TN54	Corner Sweep Slow Tri - Aura	No	No	No	#1/2/3	-	-	-
TN55	Full Sweep Slow Tri - Aura	No	No	No	#1/2/3	-	-	-
TN56	Center Sweep Slow Tri - Aura	No	No	No	#1/2/3	-	-	-
TN57	Orbit Slow Tri - Aura	No	No	No	#1/2/3	-	-	-
TN58	Double Orbit Slow Tri - Aura	No	No	No	#1/2/3	-	-	-
TN59	Retrograde Orbit Slow Tri - Aura	No	No	No	#1/2/3	-	-	-

ELECTRICAL INSTALLATION (CONT.)

ARROW PATTERNS

#	Name	SAE Compliant Timing	ECE Compliant Timing	California Title 13 Compliant Timing	Color	Sequence	fpm	fps
1	Single Fast	No	No	No	#1	-	-	-
2	Single Slow	No	No	No	#1	-	-	-
3	Chaser Fast	No	No	No	#1	-	-	-
4	Chaser Slow	No	No	No	#1	-	-	-
5	Fill Fast	No	No	No	#1	-	-	-
6	Fill Slow	No	No	No	#1	-	-	-
7	Grow/Shrink	No	No	No	#1	-	-	-
8	Warning w/Arrow	No	No	No	#1	-	-	-
9	Warning w/Arrow Fill	No	No	No	#1	-	-	-
10	Arrow Random 1	No	No	No	#1	-	-	-
11	Arrow Random 2	No	No	No	#1	-	-	-
12	Grow/Shrink 2	No	No	No	#1	-	-	-
13	Single Slow - Aura III	No	No	No	#1	-	-	-
14	Fill Slow - Aura III	No	No	No	#1	-	-	-

TABLE 1

Wire Pin #	Wire Color	Wire Function (defaults are most logical for a front or rear facing assembly)	Mods Affected	Color (If the color is not populated, it would be the next color listed)	Flash	CERT chosen
						SAE / None Pattern
1	BLU/WHT	Cruise 1	Entire Bar	Color 1, not White	-	-
2	GRN/WHT	Warning	Entire Bar (Rear/Right facing)	Color 1	Mode 2	Slow Runner
3	GRY	Left Turn	Chosen at bar creation	Chosen at bar creation	-	-
4	BLK	Right Turn	Chosen at bar creation	Chosen at bar creation	-	-
5	LTGRN	Tail	Chosen at bar creation	Red→nothing	-	-
6	BRO/WHT	Unassigned	-	-	-	-
7	PUR	Unassigned	-	-	-	-
8	WHT	Unassigned	-	-	-	-
9	BLK/WHT	Low Power 1	Entire Bar	-	-	-
10	GRY/WHT	*Left / Rearward Arrow	Entire Bar	Amber→Color 1	-	-
11	PUR/WHT	*Right / Forward Arrow	Entire Bar	Amber→Color 1	-	-
12	PNK/WHT	IGNITION	-	-	-	-
13	BLU	Warning	Entire Bar	Color 1	Mode 1	Flicker Cruise
14	GRN	Warning	Entire Bar (Front / Left facing)	Color 1	Mode 2	Slow Runner
15	YEL	Warning	Entire Bar	Color 1	Mode 3	Quint
16	ORG	Warning	Entire Bar	Color 1	Mode 4	Intercycle
17	RED	Warning	Entire Bar	Color 1	Mode 5	Warp
18	PNK	Warning with Cruise 1 behind	Entire Bar	Color 1	Mode 6	Super Slow Runner
19	RED/WHT	Flashing	Takedown / Worklight	White→nothing	-	-
20	BRO	Unassigned	-	-	-	-
21	YEL/WHT	Unassigned	-	-	-	-
22	ORG/WHT	Takedown / Worklight	Selected at Bar Creation	White	-	-
23	RED/BLK	Scene 1	Selected at Bar Creation	White	-	-
24	LTGRN/WHT	VSS Input for Speed 1 and 2	-	-	-	-

**BREAKOUT BOX INSTRUCTIONS:
(LIN COMMUNICATION)**

- Securely snap in the 4-pin and 24-pin connectors
- Install a 2Amp Fuse (customer supplied) to the end of the Red wire of the 4-pin connector harness.
- If not connecting the BOB to a 400 or 500 Siren, install a 2Amp Fuse (customer supplied) to the end of the Pink/White wire of the 24-pin connector harness and then connect to a switched ignition source
- Hook up power, ground, and LIN to the corresponding wire on the 4-pin connector harness. (Table 2)
- Refer to Table 1 for the input wire's default function
- Follow the label for the wire color to connect to a +10-32Vdc source, which turns on that given light or lights
- Make sure your wire connections are secured and isolated from any other wire

4-PIN CONNECTOR HARNESS

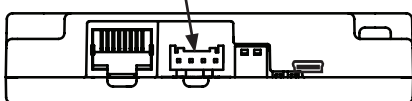

Table 2

Wire Pin	Color	Function
1	Black	Ground
2	Green/White	LIN 2 - Right or Rear mounted assemblies
3	Green	LIN 1 - Front or Left mounted assemblies
4	Red	Power

***Based upon the mounting location of your lightbar.
CAN BREAKOUT BOX INSTRUCTIONS:
(CAN COMMUNICATION)**

- Securely snap in the 4-pin, 5-pin and 24-pin connectors
- Refer to Table 1 for the input wire default functions and to Table 3 for the CAN wire functions
- Install a 2Amp Fuse (customer supplied) to the end of the Red wire of the 4-pin connector harness.
- If not connecting the BOB to a 400 or 500 Siren, install a 2Amp Fuse (customer supplied) to the end of the Pink/White wire of the 24-pin connector harness and then connect to a switched ignition source
- Hook up power, ground, and LIN to the corresponding wire on the 4-pin connector harness. (Table 2)
- Follow the label for the wire color to connect to a 10-32 Vdc source, which turns on that given light or lights
- Make sure your wire connections are secured and isolated from any other wire
- If extending the 5-pin connector harness, a shielding wire running the length of the entire harness may be necessary

CONNECTOR PRESENT WITH CAN BOB

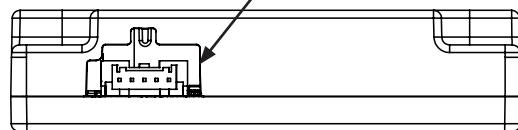
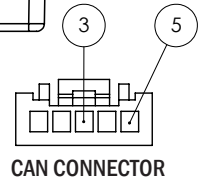
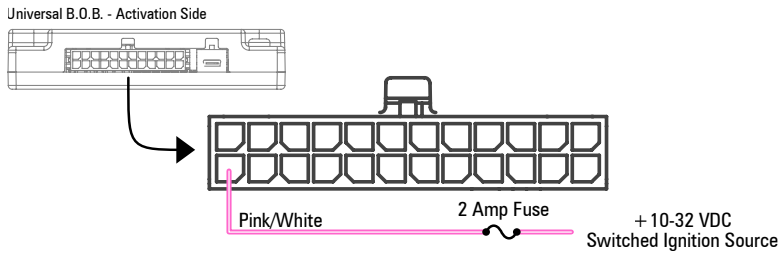
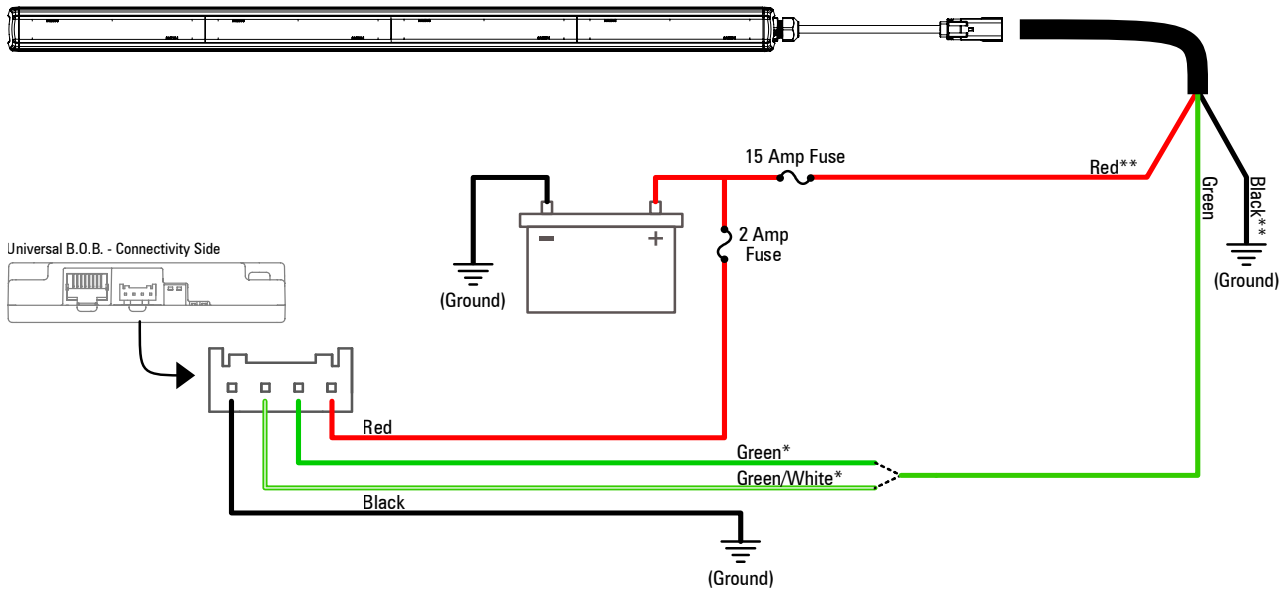

Table 3

Wire Pin	Color	Function
3	Green	CAN Low
5	Yellow	CAN High



CONTROL / WIRE HARNESS DIAGRAM



Special Notes:

- * For front or left mounted lightbars, use the green wire. For rear or right mounted lightbars, use the Green/White wire.
- ** Wire gauge depends on extension harness length:

3 Foot	18 AWG
15 Foot	16 AWG
25 Foot	14 AWG

Functional Inputs
 Functional Inputs connect to your control head or switching unit. Applying +10-32Vdc to any functional Input will activate it's function (default-active high).

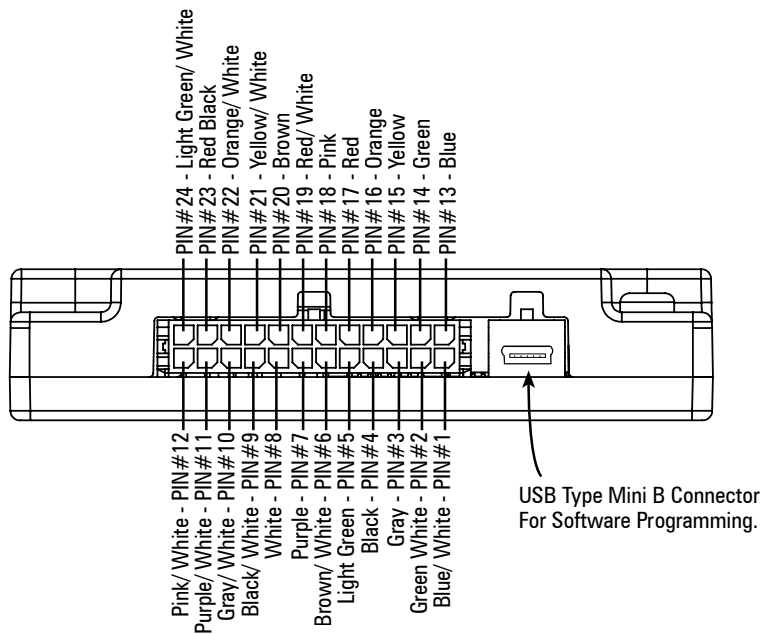

INSTALLATION: //

- 1. Locate where you want to install the mPOWER Traffic Controller.
- 2. Using the screw holes on the mounting brackets as a template, mark the hole locations on the vehicle.
- 3. Drill screw holes.
- 4. Screw the mounting bracket to the vehicle using user supplied screws.
- 5. Slide T-Bolts into the channel on the back of the Traffic Controller.
- 6. Choose the height you would like to mount your Traffic Controller and insert the T-Bolt into the coordinating hole being sure that it is oriented correctly. The side with the "BOTTOM" label should be facing down.
- 7. Tighten the Traffic Controller onto the mounting bracket with the supplied flat washer and nut.

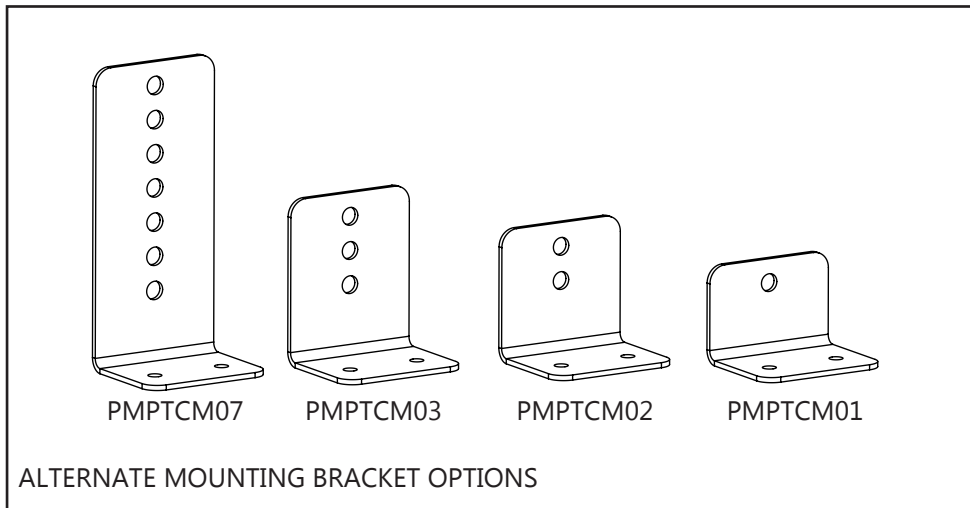
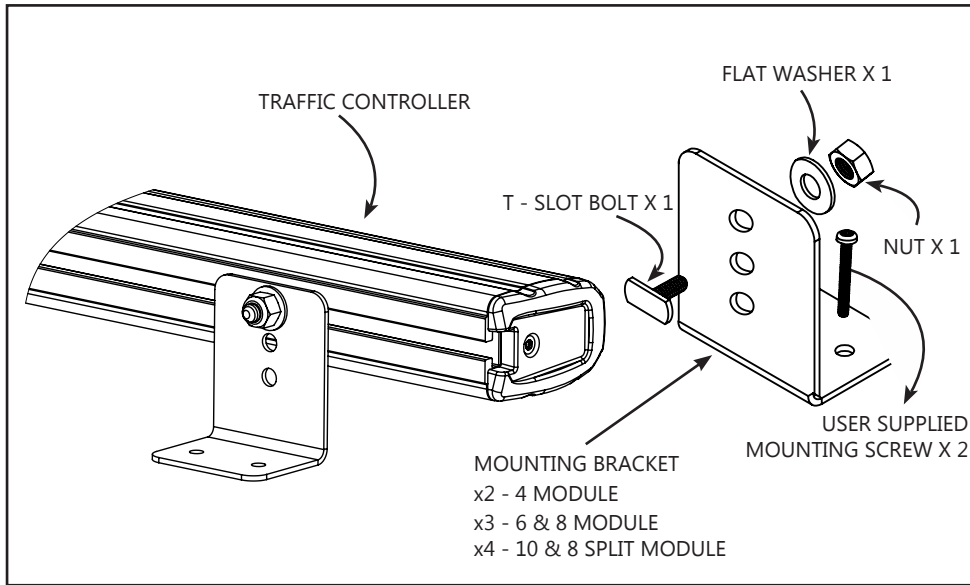

mPower® TRAFFIC CONTROLLER TROUBLESHOOTING

Normal Operation

Under Normal operation with ignition input powered, the breakout box will have the Green LED ON and the Red LED light will be ON whenever an input is active and both switches are in the UP (off) position.

GENERAL TROUBLESHOOTING	
Before further troubleshooting steps, start here:	<ul style="list-style-type: none"> • Check power source to the Traffic Controller and breakout box (red and red/white wires). • Check the ground source to the lightbar and breakout box (black and black/white wires). • Check ignition source to the lightbar and breakout box (pink/white wire). • Check any splice and butt connections for proper crimp integrity. • Check connectors for positive engagement.
NO OPERATION	
The green LED is not illuminated	<ul style="list-style-type: none"> • Check Power (Pin #4) and Ground (Pin #1) on the 4-pin connector. • If not connected to a 400 Series Siren or bluePRINT Controller, check Ignition (pin #12) on the 24-pin connector.
The red LED is not illuminated while inputs are active	<ul style="list-style-type: none"> • Verify there is proper voltage on the input wire. Many inputs are positive or negative selectable (through SoundOff Central). • Check lightbar program configuration using SoundOff Central. Verify any active inputs are mapped to activate lightbar functions. • Verify the DIP switches on the BOB are both in the up (off) position.
Green and red LEDs are illuminated properly	<ul style="list-style-type: none"> • Verify the lightbar data wires on the 4-pin connector (pins #2 or #3) are correctly connected to the Traffic Controller data wire. • Verify the data wire circuit (from the breakout box into the lightbar) is not damaged or shorted to power or ground.
INCORRECT WARNING LIGHTS	
	<ul style="list-style-type: none"> • Verify the configuration for proper lightbar operation. • Verify the lightbar data wires on the 4-pin connector (pins #2 or #3) are correctly connected to the Traffic Controller data wire. • Verify light module ID/positions.
INCORRECT OR NO ARROW OPERATION	
Breakout box LED's operating correctly	<ul style="list-style-type: none"> • Verify configuration and make sure light modules are configured for arrow function.
No steady Red LED on breakout box	<ul style="list-style-type: none"> • Check 24-pin connector at breakout box (ensure it is snapped into position correctly), check appropriate input to breakout box for output lights which should be on.

CONNECTION OF TRAFFIC CONTROLLER BREAKOUT BOX TO SOUNDOFF SIGNAL SIREN:

ETSA481CSR or ETSA482CSR

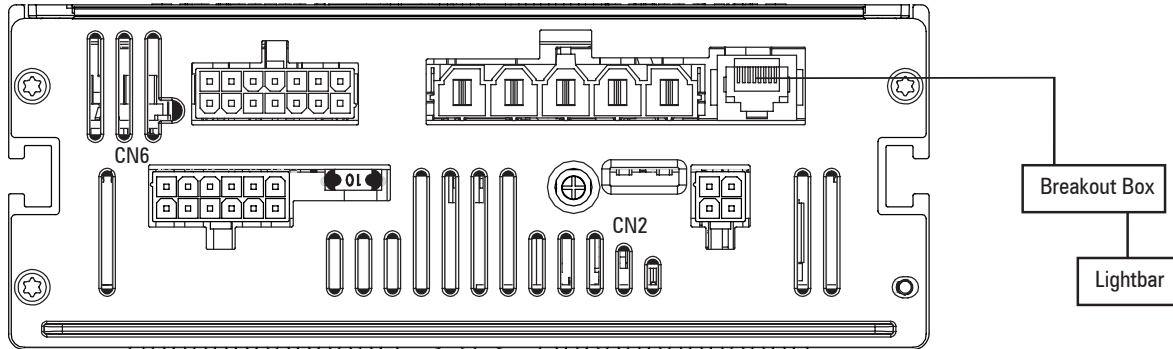

ETSA481RSP, ETSA482RSP, ETSA461HPP, ETSA462HPP

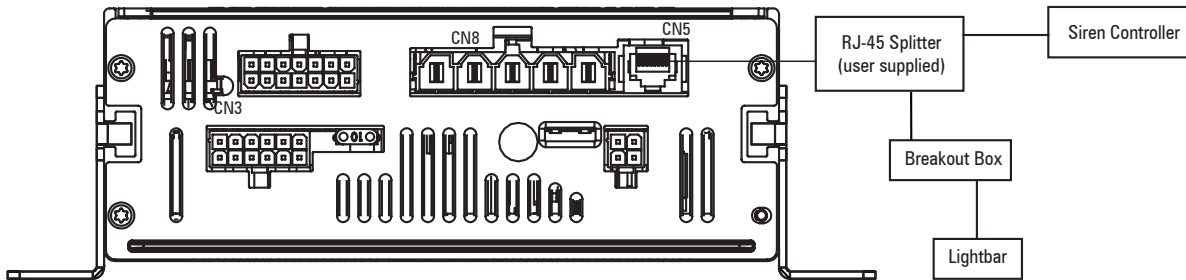

ETSA581CSR, ETSA581CSP, ETSA581RSP, or ETSA582RSP

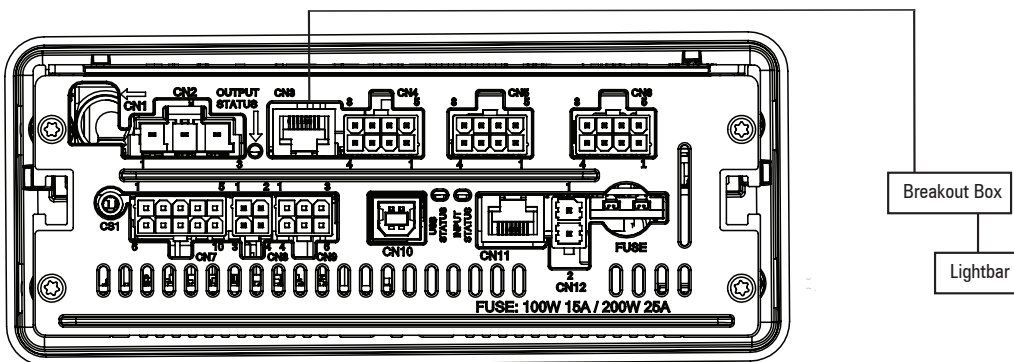

ETSA581CSR, ETSA581CSP, ETSA581RSP, or ETSA582RSP

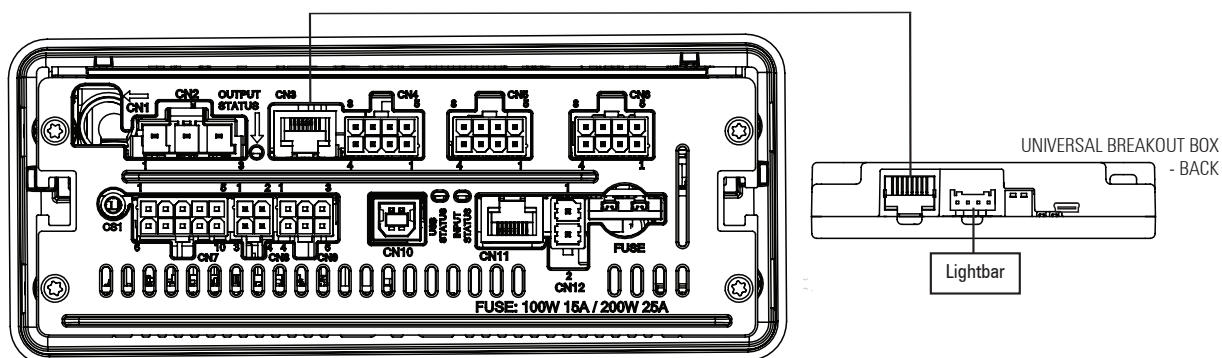

SIREN FUNCTIONS

#	Button	Function	Mods affected	"Color (if the color is not populated, it would be the next color listed)"	Flash	CERT chosen	
						SAE/ NONE	ECE
						Pattern	
S1	Pushbutton 1	*Left/Rearward Arrow	*Inboards (Rear/ Right)	Amber→ Color 1	-	-	-
S2	Pushbutton 2	-	-	-	-	-	-
S3	Pushbutton 3	-	-	-	-	-	-
S4	Pushbutton 4	Takedown	Selected at Bar Creation	White	-	-	-
S5	Pushbutton 5	Cruise 1	Entire Bar	Color 1	-	-	-
S6	Pushbutton 6	Low Power 1	Entire Bar	-	-	-	-
S7	Pushbutton 7	Scene 1	Selected at Bar Creation	White	-	-	-
S8	Pushbutton 8	-		No	-	-	-
S9	Single Button Arrow	*Right/Forward Arrow	*Inboards (Rear/ Right)	Amber→ Color 1	-	-	-
S10	Slide Switch 1	Warning	*Inboards (Rear/ Right)	Color 1	Mode 2	Slow Runner	ECE Single
S11	Slide Switch 2	Warning	Entire Bar	Color 1	Mode 3	Quint	ECE Single
S12	Slide Switch 3	Warning	Entire Bar	Color 1	Mode 4	Intercycle	ECE Single

***Based upon the mounting location of your bar**

NOTE: Requires PC configuration app to map siren control switches to Traffic Controller functions
 Plug 1 end of RJ-45 cable to available jack on siren amplifier. Plug other end of RJ-45 cable to 'siren'.

REPLACEMENT PARTS & ACCESSORIES

PART#	DESCRIPTION
PMPTCHN04	4 MOD HARNESS W/ENDCAP
PMPTCHN06	6 MOD HARNESS W/ENDCAP
PMPTCHN08	8 MOD HARNESS W/ENDCAP
PMPTCHN10	10 MOD HARNESS W/ENDCAP
PMPTCHN03	EXTERNAL EXTENSION HARNESS (3')
PMPTCHN04	EXTERNAL EXTENSION HARNESS (15')
PMPTCHN05	EXTERNAL EXTENSION HARNESS (25')
PMPTCEC01	ENDCAP (CLOSED)
PMPTCLS206xC	6" 6 LED SINGLE COLOR MODULE
PMPTCLD212xC	6" 12 LED DUAL COLOR MODULE
PMPTCLT218xxxC	6" 18 LED TRI COLOR MODULE
PEPL9BBHNS	BREAKOUT BOX HARNESS - SHORT
PEPL9BBHNL	BREAKOUT BOX HARNESS - LONG
PUVBBHNPW1	UNIVERSAL BREAKOUT BOX 4-PIN HARNESS
PUVBBJ00	UNIVERSAL LIN BREAKOUT BOX ASSEMBLY
PUVBBHNCN1	UNIVERSAL CAN BREAKOUT BOX 5-PIN HARNESS
PUVBBJC1	UNIVERSAL CAN BREAKOUT BOX ASSEMBLY
PMPTCM01	MOUNTING KIT SHORT (1 HOLE)
PMPTCM02	MOUNTING KIT MEDIUM (2 HOLE)
PMPTCM03	MOUNTING KIT LONG (3 HOLE)
PMPTCM07	MOUNTING KIT EXTRA LONG (7 HOLE)

WARRANTY & RETURN GOODS PROCEDURE

CLEANING & CARE OF YOUR LIGHTBAR:

Keeping the lenses clean and scratch free will optimize the performance of the lightbar. The exterior of the lightbar including lenses should be cleaned with mild soapy water and a soft cotton cloth to remove dirt, grime and insects. Never use window cleaners or harsh chemicals on the lenses; this may cause failure of the lenses or reduce clarity resulting in the reduction of light output.

MOUNTING INTEGRITY:

A review of bolt/hardware/mounting bracket integrity should be performed at the beginning and end of each shift.

WARNING MESSAGES - PLEASE READ:

WARNING - DRILLING ANY HOLES INTO THE LIGHTBAR IS NOT RECOMMENDED! THE RISK OF DAMAGING INTERNAL COMPONENTS AND THE RESULTING FAILURE OF THE LIGHTBAR WILL VOID ANY WARRANTY OF THIS PRODUCT.

WARNING - CARE MUST BE TAKEN WHEN DRILLING THROUGH THE ROOF OF THE VEHICLE NOT TO DRILL INTO ANY EXISTING WIRING AND NOT TO DRILL THROUGH THE HEADLINER OR SUPPORT MEMBERS OF THE VEHICLE. CHECK BOTH SIDES OF THE MOUNTING SERVICE PRIOR TO DRILLING. DE-BURR ANY HOLES AND REMOVE ANY METAL SHARDS OR REMNANTS. INSTALL GROMMETS INTO ALL WIRE PASSAGE HOLES.

WARNING - ROUTE WIRES ONLY IN LOCATIONS THAT ARE NOT SUBJECTED TO POTENTIAL WEAR. MAKE SURE TO AVOID ROUTING WIRES IN THE DEPLOYMENT AREA OF YOUR AIR BAG. REFER TO YOUR VEHICLE OWNER'S MANUAL FOR AIR BAG DEPLOYMENT ZONES.

WARNING - ALL CUSTOMER SUPPLIED POWER WIRES CONNECTING TO THE POSITIVE (+) OR NEGATIVE (-) BATTERY TERMINAL OR LOCAL CHASSIS GROUND (-) MUST BE SIZED TO SUPPLY AT LEAST 125% OF THE MAXIMUM CURRENT AND PROPERLY FUSED AT THE POWER SOURCE WITH APPROPRIATELY RATED FUSE.

IMPORTANT: When passing cables through fire wall or other sheet metal, insert grommet to protect the cable!

WARRANTY RETURN PROCESS:

Please contact your SoundOff Signal Sales Representative, Customer Services staff or our Technical Department (800.338.7337) for a RMA #, Return Merchandise Authorization Number.

The following information is required for issuance of the RMA #:

- Reason for returning the product*
- Address where replacement product is to be shipped*
- Telephone number where you may be reached*
- SoundOff Signal invoice number on which product was purchased**
- SoundOff Signal part number and serial number**
- E-mail address where RMA # should be e-mailed**
- Fax number where RMA # should be faxed**

* RMA # will not be given without this information.

** If available, please provide this information.

SoundOff Signal will NOT accept returns without an RMA #. Each RMA # is good for only one (1) return and will expire (30) days after the date it was issued. Products must be shipped back to SoundOff Signal and the RMA # clearly marked on the outside of the package near the shipping label. Please use the following address on your shipping label:

SoundOff Signal
ATTN: RMA # / Technical Services
3900 Central Parkway
Hudsonville, MI 49426

WARRANTY EXCLUSIONS:

Shipping & Handling, labor and service fees are non-refundable. SoundOff Signal is not liable for any damage due to installation or personal injury as a result of using SoundOff Signal product.

WARRANTY FORFEITURE:

Warranty will not be granted if the Warranty Return Policy & Procedure rules are not strictly followed. Physical damage resulting from customer abuse will void warranty. Warranty will also be voided if any SoundOff Signal and/or manufacturer serial tags, product stickers, seals, or the like, are removed, altered or tampered with. Returned product that is damaged by shipping via the RMA # procedure is not the responsibility of SoundOff Signal.

Document effective date on cover and below supersedes previously dated policies and statements.

There are no other warranties, expressed or implied, including, but not limited to, any implied merchantability or fitness for a particular use. SoundOff Signal reserves the right to modify this warranty statement at any time; or to discontinue, modify, or upgrade any products of its manufacture with design improvements without prior notice.

NOTES: