

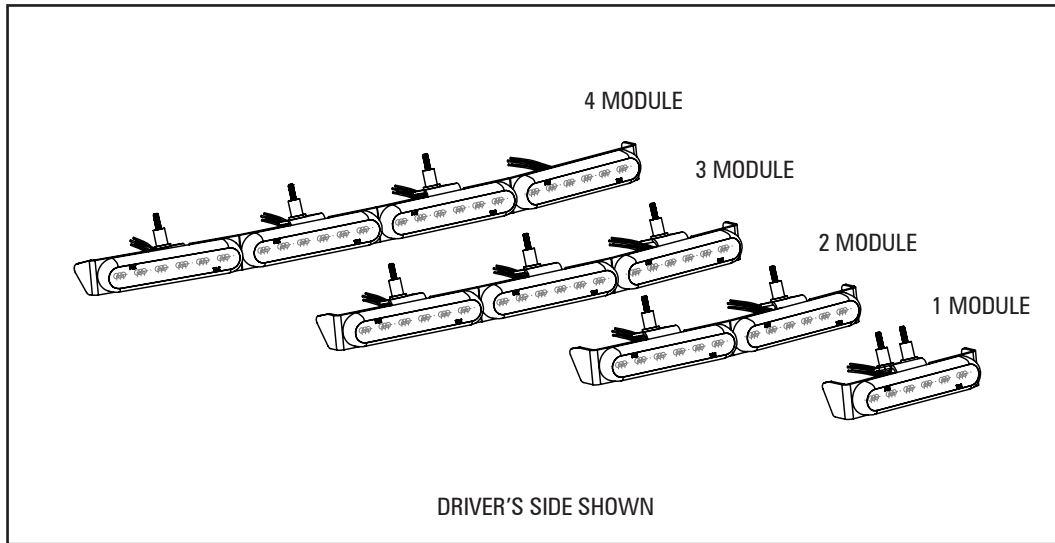

2018-2022 FORD EXPEDITION SPOILER BRACKET

PMP2RS(X)03 - For use with 4" mpower fascia Stud Mount Light



⚠ WARNING

- HIGH CURRENT interconnects must be properly terminated. Poor crimp quality can cause heat build-up and fire. Follow crimp connector manufacturer instructions.
- DO NOT install this product or route any wires in the Air Bag Deployment Zone. Refer to vehicle Owner's Manual for deployment zones.
- Do NOT use system to disconnect headlights, brake lights or other safety equipment.
- Unit may become hot to touch during normal operation.
- Failure to properly install connectors, fuses or wiring may cause vehicle failure or fire.
- Installation must only be performed by trained technician. Installer must determine vehicle wiring configuration and proper integration of system.
- Use proper wire gauge. All power wires connecting to positive (+) or negative (-) battery terminal or local chassis ground (-) must be sized to supply at least 125% of max. current and properly fused at power source.
- Install protective grommets when routing wire through firewall or metal.



1.800.338.7337 / www.soundoffsignal.com

FEATURES:

- Warning arrow greatly reduces install time through use of 3-wire technology
- Functionality mimics the rear of a lightbar
- Integrates under the spoiler of the vehicle for a seamless look
- Available in single, dual or tricolor

PART NUMBERS:

- **PMP2RS103:** Rear Spoiler Bracket, 1 Module Kit, Black, for use with mpower 4" Fascia Stud Mount Light – Ford Expedition 2018-2022
- **PMP2RS203:** Rear Spoiler Bracket, 2 Module Kit, Black, for use with mpower 4" Fascia Stud Mount Light – Ford Expedition 2018-2022
- **PMP2RS303:** Rear Spoiler Bracket, 3 Module Kit, Black, for use with mpower 4" Fascia Stud Mount Light – Ford Expedition 2018-2022
- **PMP2RS403:** Rear Spoiler Bracket, 4 Module Kit, Black, for use with mpower 4" Fascia Stud Mount Light – Ford Expedition 2018-2022

COMPONENT	QUANTITY			
	PMP2RS103	PMP2RS203	PMP2RS303	PMP2RS403
2018-2022 Ford Expedition Left Bracket	1	1	1	1
2018-2022 Ford Expedition Right Bracket	1	1	1	1
6-32 Rubber Insert	4	4	6	6
6-32 X 1.00" Torx Screw	4	4	6	6
Installation Instruction Sheet	1	1	1	1
Product Warning Card	1	1	1	1

NOTICE:

Installers and users must comply with all applicable federal, state and local laws regarding use and installation of warning devices.

Improper use or installation may void warranty coverage.

To review our Limited Warranty Statement & Return Policy for this or any SoundOff Signal product, visit our website at www.soundoffsignal.com/tech-services/returns/.

If you have questions regarding this product, contact **Technical Services**, Monday - Friday, 8 a.m. to 5 p.m. ET at 1.800.338.7337 (press #4).

Questions or comments that do not require immediate attention may be emailed to techservices@soundoffsignal.com.

ENHANCING SAFETY THROUGH INNOVATION

2018-2022 FORD EXPEDITION SPOILER BRACKET

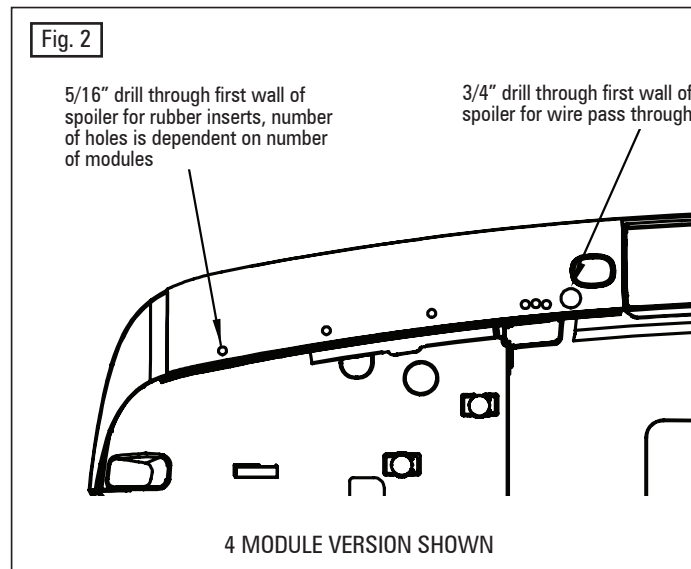
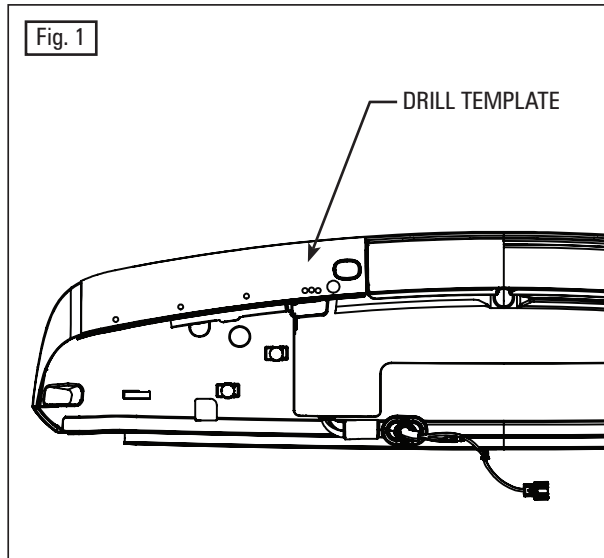

INSTALLATION:

1. Remove rear spoiler from the vehicle using the manufacturer's recommended method. Lay the included drill template onto the driver's side of the spoiler, as shown in Fig. 1. Line up the template with the seam on the outer edge of the spoiler to properly position it.
2. Secure the template in place with non-marking tape.
3. Refer to the chart below and to the included template for drill instructions:

BRACKET TYPE	MOUNTING HOLES
1 MODULE	D, F
2 MODULE	C, E
3 MODULE	B, C, E
4 MODULE	A, B, C

4. Scribe the drill locations indicated by the template, remove the template, and drill, as shown in Fig. 2.

NOTICE:

Installers and users must comply with all applicable federal, state and local laws regarding use and installation of warning devices.

Improper use or installation may void warranty coverage.

To review our Limited Warranty Statement & Return Policy for this or any SoundOff Signal product, visit our website at www.soundoffsignal.com/tech-services/returns/.

If you have questions regarding this product, contact **Technical Services**, Monday - Friday, 8 a.m. to 5 p.m. ET at 1.800.338.7337 (press #4).

Questions or comments that do not require immediate attention may be emailed to techservices@soundoffsignal.com.

2018-2022 FORD EXPEDITION SPOILER BRACKET

Fig. 3

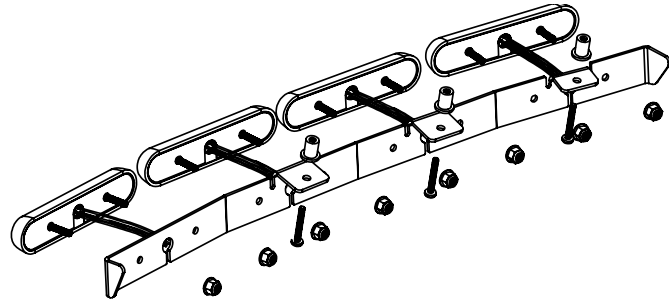

4 MODULE VERSION SHOWN

Fig. 4

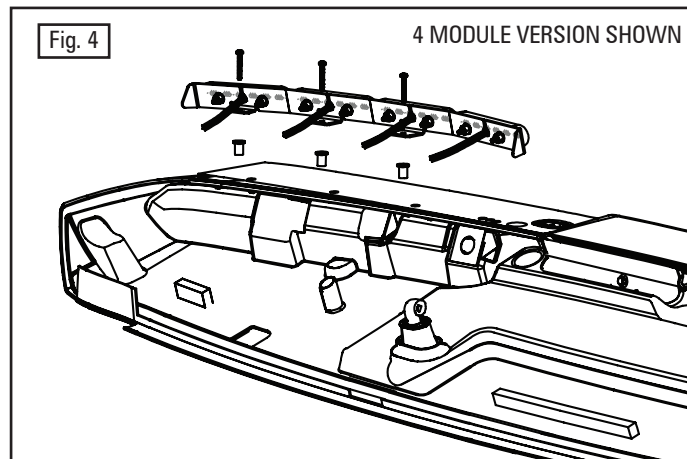

4 MODULE VERSION SHOWN

INSTALLATION (CONT):

5. Flip the drill template over and lay on passenger's side. Temporarily, secure in place with non-marking tape. Scribe the drill locations indicated by the template.
6. Remove the template and drill as indicated.

If a configured, mPower® Arrow Kit was purchased, skip to Step 8.

7. Attach the lights to the included brackets, as shown in Fig. 3. Secure nuts 1/8" turn past seated contact.
8. Press the 6-32 rubber inserts into the spoiler. Then place the bracket, as shown in Fig. 4. Route wires through the wire pass through hole. Secure with screws supplied. Repeat for opposite side.

NOTE: If the hatch sheet metal contains an existing hole to route wires into the vehicle, skip to Step 11.

9. Identify a location in which to drill a 1-3/8" hole in the hatch sheet metal in order to place the grommet and run wires into the vehicle.
10. Insert the provided grommet into the hole.
11. Run the wires into the hole and make final connections.
12. Before re-installing the rear spoiler, make all electrical connections. Refer to the mPower arrow kit instruction sheets for details.

NOTICE:

Installers and users must comply with all applicable federal, state and local laws regarding use and installation of warning devices.

Improper use or installation may void warranty coverage.

To review our Limited Warranty Statement & Return Policy for this or any SoundOff Signal product, visit our website at www.soundoffsignal.com/tech-services/returns/.

If you have questions regarding this product, contact **Technical Services**, Monday - Friday, 8 a.m. to 5 p.m. ET at 1.800.338.7337 (press #4).

Questions or comments that do not require immediate attention may be emailed to techservices@soundoffsignal.com.