

## MODULATING ELECTRONIC FLASHER

### E.T.M. (EMERGENCY TRAFFIC MOVER) ETTM00-P

Congratulations! You are now the proud owner of the most technically advanced Modulating Headlight Flasher System in the market today. Add to it our never ending commitment to quality, this new Flasher System will provide you with years of dependable trouble free service.

The SoundOff Signal E.T.M. will operate a two or four headlight system on any vehicle with a 12 VDC negative ground system.

#### NOTE

This Flasher will not work on any ground side switched system. If you have any questions regarding what type of system your vehicle has, contact SoundOff Signal's Technical Support Department at 1-800-338-7337.

A properly installed E.T.M. will modulate the vehicles high beam lights at a constant flash rate (3.6 flashes per second). When used at night, the low beam headlights remain ON for proper illumination, while the high beams flash to gain attention and increase the vehicles visibility. When the dimmer switch is activated to high beam, the Flasher Systems "High Beam Override" interrupts the Flasher sequence to allow for normal high beam function. Flashing automatically resumes when the dimmer switch is deactivated.

#### NOTE

Flashing Headlight and Taillight Systems are intended for use on approved vehicles ONLY. It is the responsibility of the user of these systems to insure compliance to any Federal, State or Municipal regulations which may apply.

#### INSTALLATION

**MOUNTING:** Mount the flasher near the battery at the front of the engine compartment.

**GREEN WIRE:** Connect to a convenient reliable ground.

**RED WIRE:** Connect to a powered switch. This switch will only require 1/4 amp to activate the flasher.

**WHITE WIRES:** "T" or tap either white wire to the vehicle's high beam headlight wire that runs between the dimmer switch and the driver side headlight. Connect through an ATO type fuse (20 amp) to the positive post of the battery. DO NOT USE A CIRCUIT BREAKER, FUSIBLE LINK OR SLOW BLOW TYPE FUSE.

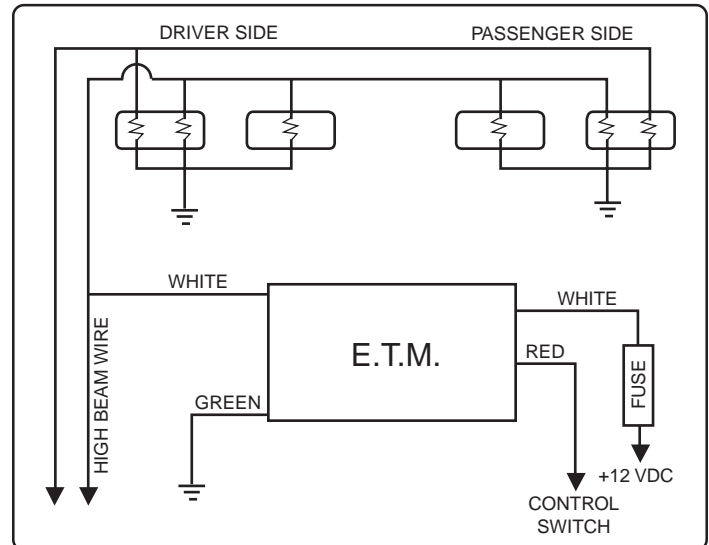

**Wiring Schematic**

#### NOTE

Older 4 bulb Sealed Beam Headlight Systems may require a 30 amp fuse. Call SoundOff Signal's Technical Support Department at 1-800-338-7337 for any further assistance.

**Note:** Due to changes in the 2006 Ford Crown Vic / Police Interceptor, the enclosed flasher will not work on this vehicle. Please contact SoundOff Signal at 1-800-338-7337 for other options.

#### WARRANTY

SoundOff Signal warrants the ETTM00-P Electronic Flasher System for 1 (one) full year from date of purchase to the original purchaser against any manufacturer defects or workmanship. This warranty applies only to units installed according to manufacturer's installation instructions and operated within the units specifications.

Warranty is void if the unit was installed incorrectly or maliciously damaged.

All warranty claims must be accompanied by a dated proof of purchase.

SoundOff Signal retains the right to be the sole mediator of what constitutes defects in performance or manufacturing.

E.T.M. covered by U.S. Patent #'s 4114071 & 4309639