

## ROOF RAIL BRACKETS AND HOOK BRACKET MOUNTING INSTRUCTIONS

- Slide the 1/4-20 inch T-bolts into the extrusion t-slots. Place mounting foot onto slots and tighten foot with washer and nut, ensuring the use of either a lock washer or lock nut.
- Temporarily place lightbar on the van roof, between two of the mounting holes provided on the rain gutter. It is recommended that the bar is positioned about the center of the vehicle.
- Install supplied vehicle specific hook brackets using supplied 1/4"-20 x 2.5 Hex Head bolts onto the bar mounting foot as shown. Nut is attached to mounting foot to prevent turning and improve ease of installation.
- Position the hook bracket roof rail on the van's rain gutter. Align the slots from the bracket with the OEM mounting points from the roof of the van.
- Remove the plastic caps covering the mounting points of the van. Use a utility knife to cut paint if necessary.
- After removing the plastic caps plugging the mounting holes, enlarge the mounting holes using a 7/16" or 11mm drill to fit the blind fasteners. Use M8 blind fasteners on the 4 locations (not provided). The BLIND FASTENER or RIVET NUT GUN is NOT provided on the kit. Please follow the instructions on installing the Blind Fastener and continue to step 7.
- Use M8 x 30mm bolts to attach the hook bracket roof rail to the van's roof.
- Tighten the hook bracket to mounting foot by turning the 1/4" x 2.5" Hex head bolt clockwise until bar is snug and no side to side or fore to aft movement occurs. Tighten to 50 inch lbs max.
- Route cables into vehicle. Use supplied rubber grommet in roof for sealing/ protection of wires. It is recommended that silicone be placed around grommet to ensure roof sealing.

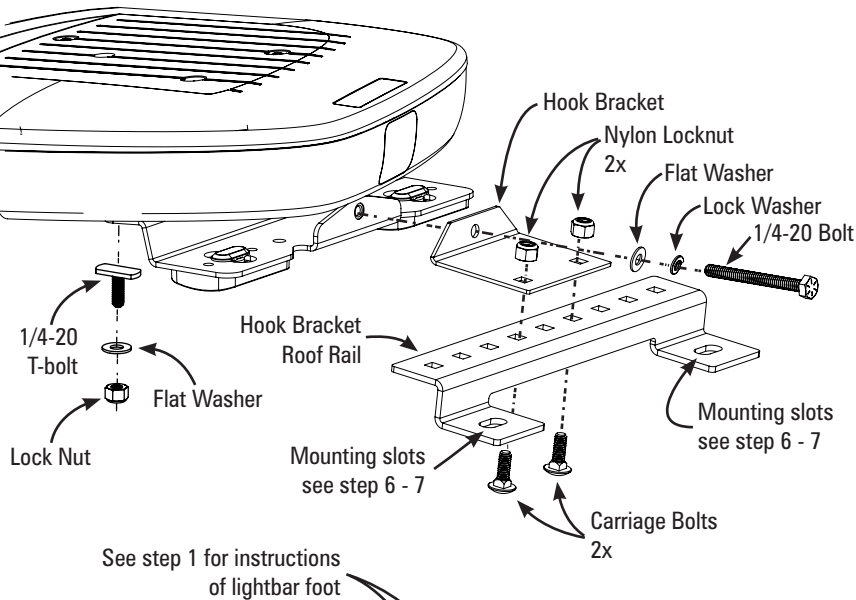

T-Slots for adjustability for correct roof fit

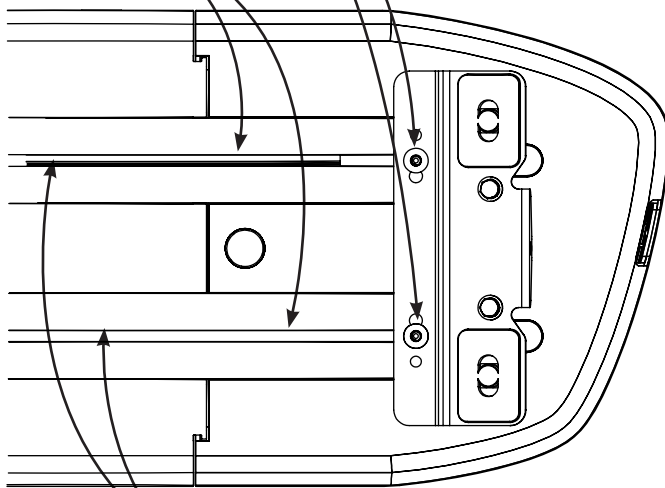

T-Slot Gasket location

### **⚠ WARNING**

Care must be taken when drilling through the roof of the vehicle not to drill into any existing wiring and not to drill through the headliner or support members of the vehicle. Check both sides of the mounting service prior to drilling. De-burr any holes and remove any metal shards or remnants. Install grommets into all wire passage holes.

### **⚠ WARNING**

Route wires only in locations that are not subjected to potential wear. Make sure to avoid routing wires in the deployment area of your air bag. Refer to your vehicle's owner's manual for airbag deployment zone.

#### IMPORTANT INFORMATION:

Warning devices are strictly regulated and governed by Federal, State and Municipal ordinances. These devices shall be used ONLY on approved vehicles. It is the sole responsibility of the user of these devices to ensure compliance.

To review our Limited Warranty Statement & Return Policy for this or any SoundOff Signal product, visit our website at [www.soundoffsignal.com/sales-support](http://www.soundoffsignal.com/sales-support). If you have questions regarding this product, contact **Technical Services**, Monday - Friday, 8 a.m. to 5 p.m. at 1.800338.7337 (press #4 to skip the automated message). Questions or comments that do not require immediate attention may be emailed to [techservices@soundoffsignal.com](mailto:techservices@soundoffsignal.com).