

3900 Central Parkway
Hudsonville, MI 49426
toll free 800.338.7337
office 616.896.7100
techsupport@soundoffsignal.com
www.soundoffsignal.com

Self-Contained Traffic Master Warning Bar

Power: 10-30Vdc
Max Current Draw: 2.2 Amps
Reverse Polarity Protection: YES
Transient Protection: YES
Temperature: -30degC to +60degC

Installation and Mounting

General:
All devices should be mounted in accordance with the manufacturer's instructions and securely fastened to the vehicle elements of sufficient strength to withstand the forces applied to the device.

Wiring:

NOTE! USE AUTOMOTIVE ATO FUSES ONLY

- Power through 5 Amp ATO fuses which should be located as close to the vehicle power takeoff points as possible.

- Ground terminations should only be made to the substantial chassis components directly to the vehicle battery.

- Do not use insulation displacement connectors.

- Route wiring using grommets and sealant when passing through compartment walls.

Mounting

1. Using a flat head screw driver, disconnect the 9 wires that run from the bar to the control box from the terminal block. Take note of their terminal block locations for future reference.

2. Install mounting brackets to both ends of the lightbar by uninstalling the two screws on either side of the light. Remove and throw away plastic washers before re-installing screws with metal brackets. See Figure 1 for details

3. Prior to drilling or mounting, consideration should be given to cable location and light placement. The cable should exit the end cap on the driver's side unless otherwise specified. Using the light as a template, mark the location of the (4) mounting holes on either end of the light and the wire exit location.

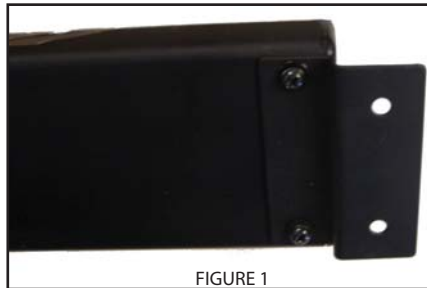

FIGURE 1

4. Drill a 1 1/4" hole for the wire entry to the vehicle. There is a grommet provided with the installation kit that should be placed between mounting surface and light to seal wire entry hole into vehicle.

5. Drill (4) appropriately sized mounting holes for installer supplied mounting screws.

6. Using installer supplied screws, attached the light to the vehicle.

7. Route control cable to appropriate location for mounting external control box.

8. Remove strain relief/wire seal from empty black plastic control box cover supplied in your installation kit. Feed the control wire from the bar through the strain relief as shown in Fig 1.



FIGURE 2

9. Reinstall strain relief/wire seal to empty black plastic control box cover. Be sure to use supplied nut on inside of the cover to secure strain relief to cover.

10. Feed wires through the supplied gaskets and bracket to terminal block that was disconnected in Step 1. Refer to Figure 3 for terminal block locations.

Location 1 - White
Location 2 - Black
Location 3 - Red
Location 4 - Pink
Location 5 - Yellow
Location 6 - Light Green
Location 7 - Blue
Location 8 - Dark Green
Location 9 - Violet

11. Using supplied screws, assemble control box with cover. Ensure gaskets are placed as shown in figure 4.

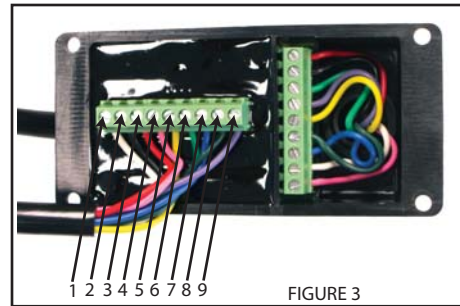

FIGURE 3

12. Mount Assembled control box in desired location using installer supplied screws.

13. Route the wires that come out of the external control box to your user supplied switching location.

Control Wires and Function

RED: +10-30Vdc
BLACK: Ground
WHITE: MOMENTARY GND TO CHNG WARNING PATTERN ACTIVATION
PINK: WARNING MODULES ON ENDS
BLUE: Apply Power to activate SOLID RIGHT ARROW
GREEN: Apply Power to activate FLASH MODE 2
YELLOW: Apply Power to activate SOLID CENTER OUT
PURPLE: Apply Power to activate FLASH MODE 1
DARK GREEN: Apply Power to activate SOLID LEFT ARROW

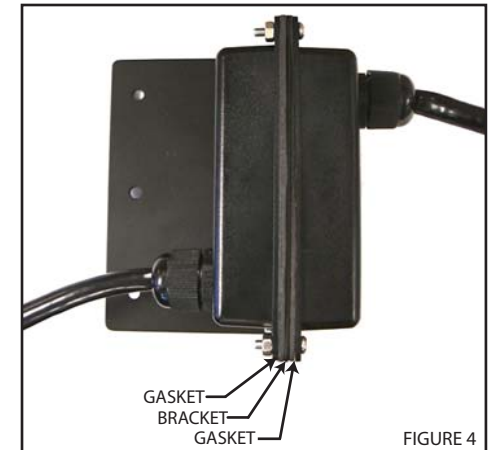

FIGURE 4

WARNING: Warning devices are strictly regulated and governed by Federal, State and Municipal ordinances. These devices shall be used ONLY on approved vehicles. It is the sole responsibility of the user of these devices to ensure compliance.

Directional Patterns

#	NAME	DESCRIPTION
1	SOLID LEFT ARROW	-
2	SOLID RIGHT ARROW	-
3	SOLID CENTER OUT	-
4	FLASH MODE 1	OUTER 4, INNER 2 ALTERNATING
5	FLASH MODE 2	LEFT 3, RIGHT 3 ALTERNATING