

Figure 2. Mounting Configurations
(View shown from rear of LED Bar)

3. Mount the Split Arrow LED Traffic Master bracket on the front or rear of the light bar frame as desired. Use either existing holes in the light bar frame, if available, or drill holes as needed.

NOTE

Remember to properly seal all holes made in any light bar to prevent water damage.

4. Turn the light bar right side up and attach the Split Arrow LED Traffic Master to its mounting bracket as shown in Figure 4. **Use ONLY 5 x 10mm bolts.**
5. Put the light bar on the vehicle roof making sure not to scratch the vehicle. Check for clearance below the light bar as you proceed.
6. Reposition the light bar and secure it to the vehicle.
7. Tighten the bolts that hold the Split Arrow LED Traffic Master mounting bracket to the light bar, checking that the brackets are aligned with each other. Some adjustment of these brackets may be required to insure that the directional signal is level. Adjust as necessary.
8. Position the Split Arrow LED Traffic Master in the center of the vehicle and tighten the bolts that hold it to the mounting bracket.

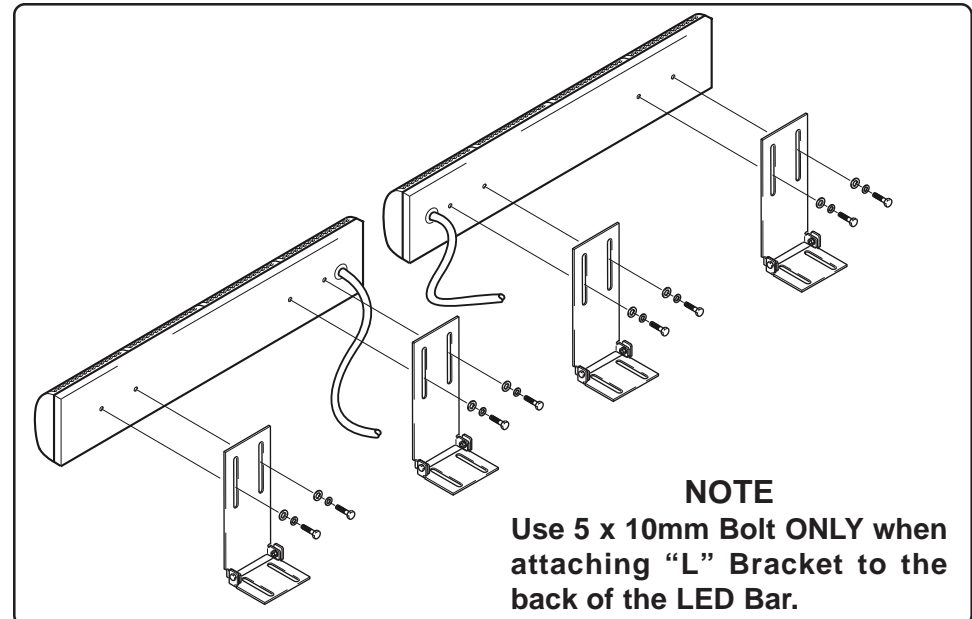

NOTE
Use 5 x 10mm Bolt ONLY when attaching "L" Bracket to the back of the LED Bar.

Figure 3. Rear Deck Mounting

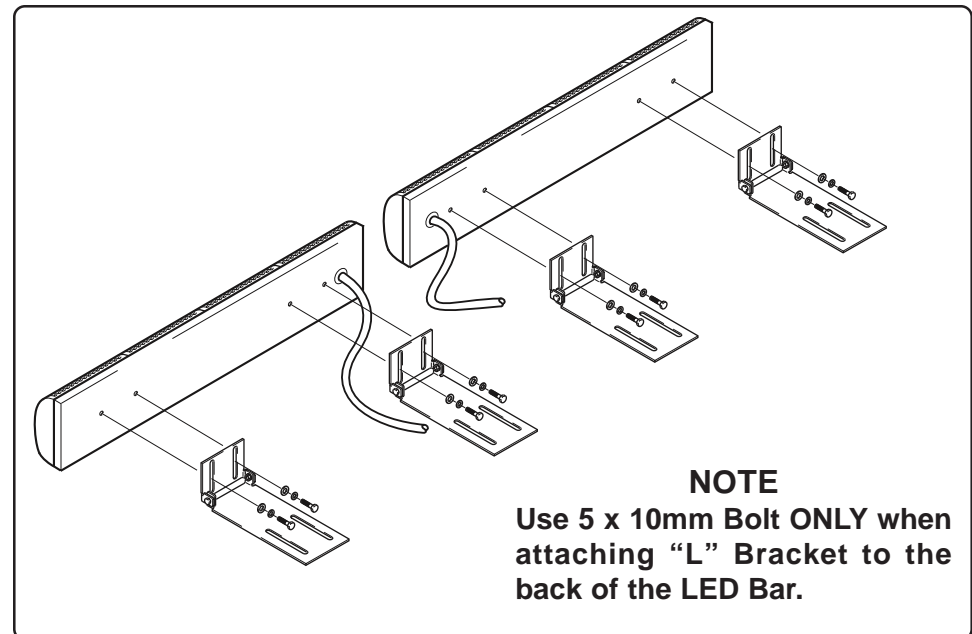

NOTE
Use 5 x 10mm Bolt ONLY when attaching "L" Bracket to the back of the LED Bar.

Figure 4. Light Bar Mounting

CONTROL MODULE WIRING

NOTE

DO NOT USE FUSIBLE LINKS, CIRCUIT BREAKERS OR GLASS FUSES!!!

1. Choose the ideal mounting location for the Control Module. It fits into any standard vehicle console that is designed to hold radio or other electronic equipment. It also works well when mounted under the vehicle's dash.

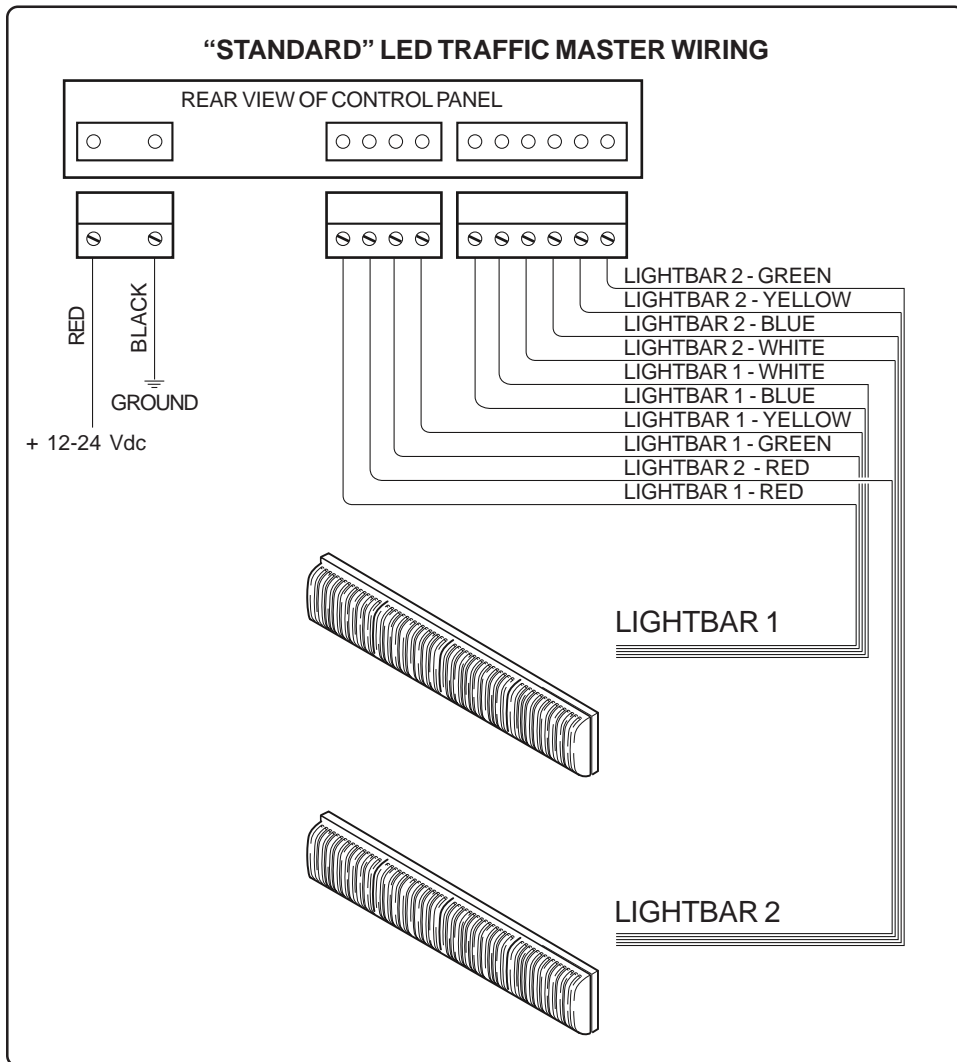

Figure 5. Standard and Optional Wiring Schematics

FAILURE TO FOLLOW THE WARNINGS OR INSTALLATION AND USER INSTRUCTIONS CAN RESULT IN LOSS OF WARRANTY COVERAGE.

The following installation instructions provide direction for mounting the Traffic Master to most light bar frames. Questions about a specific application should be directed to the **Technical Service Hotline at (800) 338-7337**.

PERMANENT MOUNTING

Prior to mounting, consideration should be given to cable location and lamp replacement. The cable should exit the end cap on the driver's side unless otherwise specified. The lamp module replacement procedure is explained in the Maintenance section of this manual.

REAR DECK AND LIGHT BAR MOUNTING

The Split Arrow LED Traffic Master should be mounted using the adjustable “L” brackets which are provided. Refer to page 5 for specific mounting instructions. In addition, note Figure 2, relating to mounting configurations and STANDARD or OPTIONAL wiring specification. See page 7, Figure 5 for specific wiring.

1. If a light bar is already mounted on the vehicle, remove the light bar from the vehicle roof and turn it upside down. Rest it on a cloth or some other soft surface. It is not necessary to disconnect the wiring.
2. Select and assemble the adjustable “L” Bracket that fits your specific needs. (See Fig. 1) Standard Bracket - recommended for rear deck and light bar mounting. Heavy Duty Bracket - for use when Traffic Master will be subject to high wind, vibration, and/or severe stress.

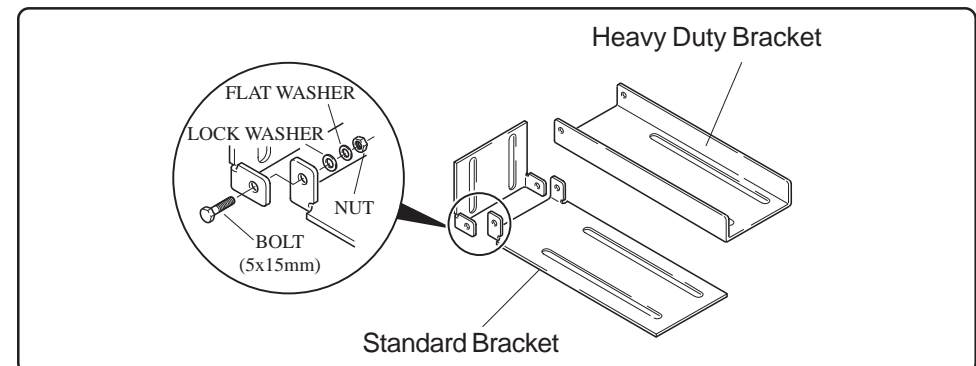

Figure 1. “L” Bracket Assembly

PROPER INSTALLATION COMBINED WITH OPERATOR TRAINING IN THE PROPER USE OF EMERGENCY WARNING DEVICES IS ESSENTIAL TO INSURE THE SAFETY OF EMERGENCY PERSONNEL AND THE PUBLIC.

INSTALLATION AND MOUNTING

GENERAL

All devices should be mounted in accordance with the manufacturer's instructions and securely fastened to vehicle elements of sufficient strength to withstand the forces applied to the device.

WIRING

Do not use insulation displacement connectors (e.g. 3M Scotchlock type connectors). Route wiring using grommets and sealant when passing through compartment walls. High ambient temperatures (e.g. under-hood) will significantly reduce the current carrying capacity of wires, fuses, and circuit breakers. Use "SXL" type wire in engine compartment. Minimize the number of splices to reduce voltage drop. All wiring should conform to the minimum wire size and other recommendations of the manufacturer and be protected from moving parts and hot surfaces. Looms, grommets, cable ties, and similar installation hardware should be used to anchor and protect all wiring.

Particular attention should be paid to the location and method of making electrical connections and splices to protect these points from corrosion and loss of conductivity. Ground terminations should only be made to substantial chassis components, preferably directly to the vehicle battery.

The user should install a fuse sized to approximately 125% of the maximum amp capacity in the supply line and each switched circuit to protect against short circuits. For example, a 5 amp fuse should carry a maximum of 4 amps. Circuit breakers are very sensitive to high temperatures and will "false trip" when mounted in hot environments or operated close to their capacity.

Fuses should be located as close to the vehicle power takeoff points as possible and properly sized to protect the wiring devices.

- Route a 18 AWG wire attached to a reliable ground source. The vehicle's battery is the ideal source. NEVER FEED RADIO EQUIPMENT WITH THE SAME GROUND CIRCUIT!!!! THIS CAN CAUSE ELECTROMAGNETIC INTERFERENCE WITH COMMUNICATION EQUIPMENT.
- Route a 18 AWG wire attached to a power source (12 VDC). The vehicle's battery is again the ideal source. Place a 5 amp in-line blade type fuse on this circuit. DO NOT USE FUSIBLE LINKS, CIRCUIT BREAKERS, OR GLASS FUSES!!!
- Attach the power and ground wire to the appropriate pins in the 2 pin socket housing as shown in Figure 5.
- Attach the wires from the two 5 wire harnesses into the appropriate 6 & 4 pin connectors as shown in Figure 5. BE SURE TO PLACE THE PINS IN THE PROPER SEQUENCE!!!
- With the control module switched to the "OFF " position, plug the two pin socket housing into the appropriate position in the rear of the control module.
- Mount the Control Module in the selected location.

The LED's on the control box mimic the actions of the LED Traffic Master to ensure proper selections and operation of the pattern chosen. If the LED Traffic Master is not functioning correctly, call the **SoundOff Signal Technical Service Hotline at (800) 338-7337**.

OPERATIONS

A five position rotary switch controls all of the LED Traffic Master's primary functions. The LED Traffic Master Control Module faceplate is shown in Figure 6.

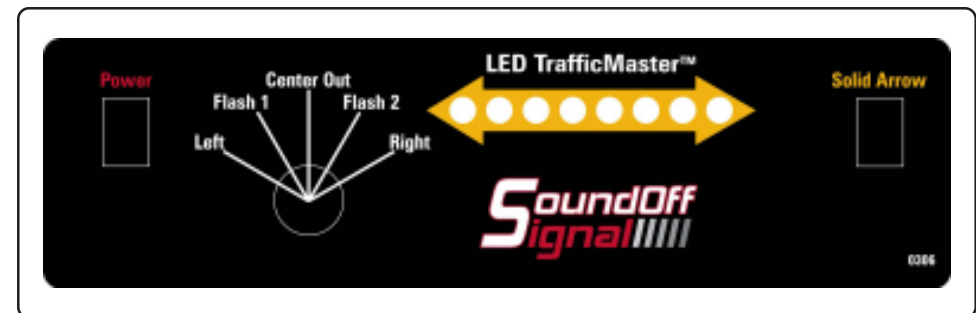

Figure 6. Control Module Faceplate

MAINTENANCE

The LED Traffic Master requires little routine maintenance. Occasional cleaning of the lens is all that is required to sustain maximum light output. Use plain water and a soft cloth or lens polish and a very soft paper towel or facial tissue. Since plastic scratches easily, cleaning is recommended only when necessary.

Changing an LED MODULE

(Refer to Figure 7)

- 1) Determine the location of the nonworking LED module.
- 2) Remove the 4 phillips head screws on the back of the Light Bar that hold the nonworking LED module.
- 3) Gently pull the LED module away from the bar.
- 4) Disconnect the wires from the screw terminals on the back of the LED module. **NOTE:** White wires go to the (+) terminal and the colored wire goes to the (-) terminal.
5. Reconnect the wires to the new LED module. **NOTE:** The use of conductive grease on the wire contact is recommended.
6. Reattach LED module to Light Bar.

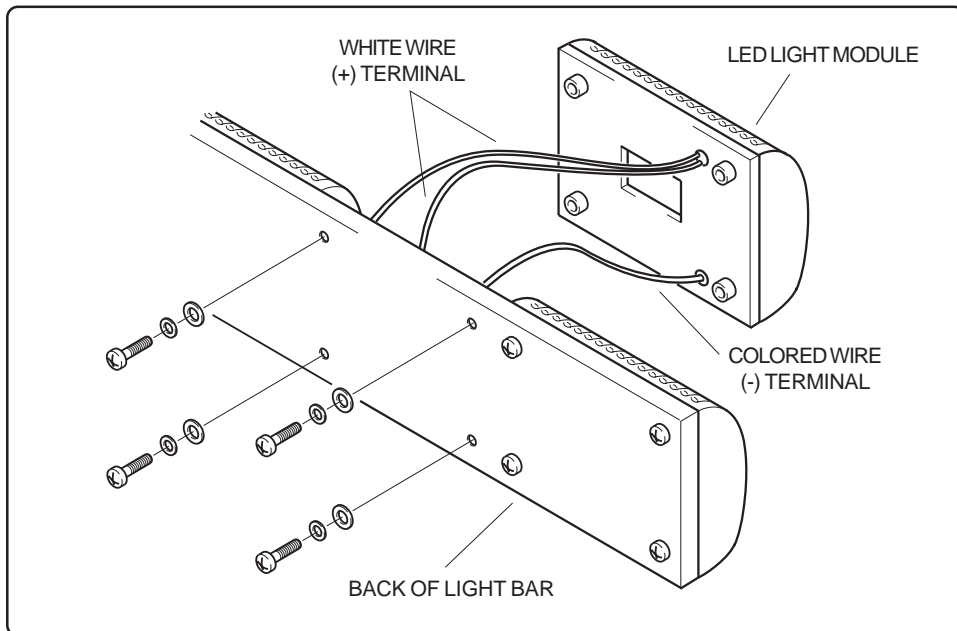

Figure 7. Changing the LED Module

OVERVIEW

The use of this or any warning device does not insure that all drivers can or will observe or react to an emergency warning signal. Never take the right-of-way for granted. It is the operator's responsibility to be sure they can proceed safely before entering an intersection, driving against traffic, responding at a high rate of speed or walking on or around traffic lanes.

The effectiveness of this warning device is highly dependent upon correct mounting and wiring. Read and follow the manufacturer's instructions before installing or using this device. The vehicle operator should insure daily that all features of the device operate correctly. In use, the vehicle operator should insure the projection of the warning signal is not blocked by vehicle components (i.e.: open trunks or compartment doors), people, vehicles, or other obstructions.

This equipment is intended for use by authorized personnel only. It is the user's responsibility to understand and obey all laws regarding emergency warning devices. The user should check all applicable city, state and federal laws and regulations.

SoundOff Signal assumes no liability for any loss resulting from the use of this warning device. Proper installation is vital to the performance of this warning device and the safe operation of the emergency vehicle. Warning devices should be installed in such a manner as to: A) Not reduce the output performance of the system, B) Place the controls within convenient reach of the operator so that he can operate the system without losing eye contact with the roadway. Properly protect and use caution around live electrical connections. Grounding or shorting of electrical connections can cause high current arcing, which can cause personal injury and/or severe vehicle damage, including fire.

Any electronic device may create or be affected by electromagnetic interference. After installation of any electronic device, operate all equipment simultaneously to insure that operation is free of interference. Never power emergency warning equipment from the same circuit or share the same ground circuit with radio communication equipment.

SPLIT ARROW LED TRAFFIC MASTER DIRECTIONAL SIGNAL BAR

[ETTMLEDSA]

INTRODUCTION

The SPLIT ARROW LED TRAFFIC MASTER DIRECTIONAL SIGNAL is a revolutionary new emergency warning product. It is a high intensity Traffic Directing device in a compact size that can be mounted almost anywhere.

Offering maximum light intensity with minimum power draw, the Split Arrow LED Traffic Master draws a maximum of 2.2 amps under standard conditions. The Split Arrow LED Traffic Master can also operate at either 12 or 24 volts. The solid state design and absence of moving parts make the LED Traffic Master virtually repair free.

The LED Traffic Master delivers eight (8) distinct warning patterns - Left Arrow, Right Arrow, Center Out, Flash Mode 1, Flash Mode 2 as well as Solid Arrow Right, Solid Arrow Left and Solid Arrow Split.

INSTALLER: This manual must be delivered to the end user of this equipment!

ADJUST CONTROL BOX KNOB

1. Gently pry off the knob's end cap.
2. Insert a 10mm socket on to adjustment nut.
3. To loosen, turn counter clockwise.
4. To tighten, turn clockwise.

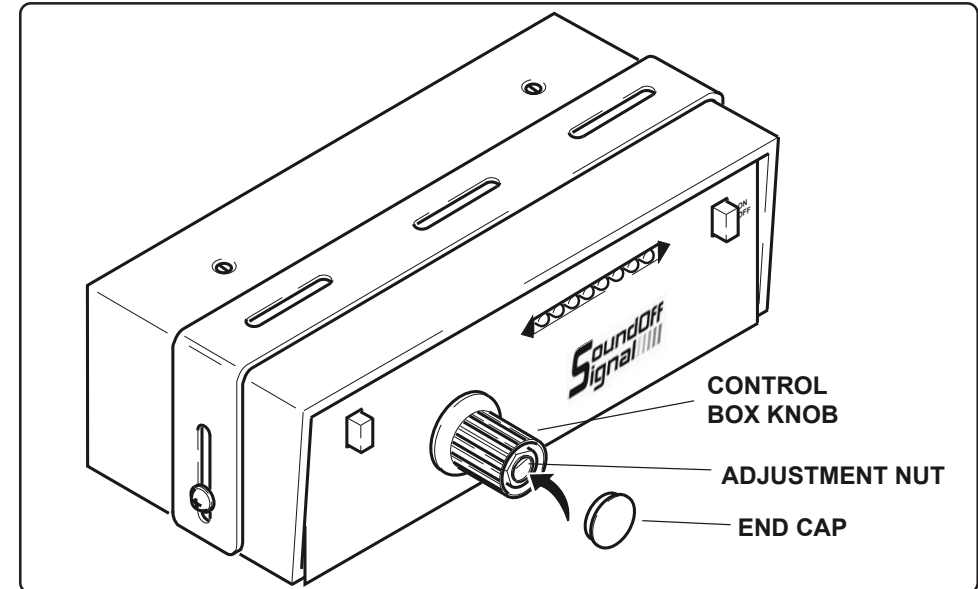

Figure 8. Adjust Control Box Knob

REPLACEMENT PARTS

Part #	Description
PLMCTMLED	LED Center Light Module
PLMATMLED	LED Arrow Light Module
ETTMLEXT25	25' LED Extension Cable
PBKTLLEDTM	Adjustable "L" Bracket
ET2CBTML	LED Control Head



Split Arrow LED Traffic Master

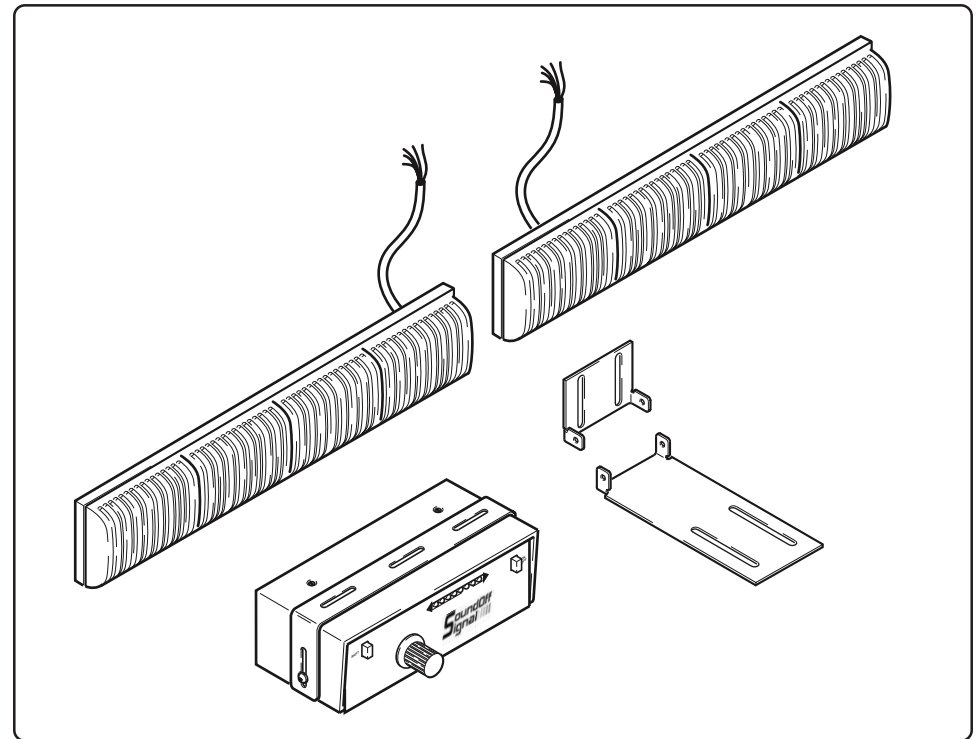

Installation & Operation Instructions



3900 Central Parkway
Hudsonville, MI 49426
toll free 800.338.7337
office 616.896.7100
techsupport@soundoffsignal.com
www.soundoffsignal.com