

FLASHBACK™ ALTERNATING TAILLIGHT FLASHER

ETTFK02 - 2010-2020 DODGE DURANGO TAILLIGHT FLASHER KIT WITH CONNECTORS ON EXIT WIRES & WIRE HARNESS

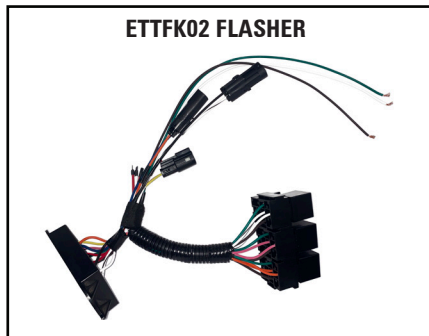

ETTFK02 FLASHER



CENTER LIGHT HARNESS



DRIVER TAIL LIGHT HARNESS



PASSENGER TAIL LIGHT HARNESS

Please see next page for Technical Specifications

⚠ WARNING

- HIGH CURRENT interconnects must be properly terminated. Poor crimp quality can cause heat build-up and fire. Follow crimp connector manufacturer instructions.
- DO NOT install this product or route any wires in the Air Bag Deployment Zone. Refer to vehicle Owner's Manual for deployment zones.
- Do NOT use system to disconnect headlights, brake lights or other safety equipment.
- Unit may become hot to touch during normal operation.
- Failure to properly install connectors, fuses or wiring may cause vehicle failure or fire.
- Installation must only be performed by trained technician. Installer must determine vehicle wiring configuration and proper integration of system.
- Use proper wire gauge. All power wires connecting to positive (+) or negative (-) battery terminal or local chassis ground (-) must be sized to supply at least 125% of max. current and properly fused at power source.
- Install protective grommets when routing wire through firewall or metal.

SoundOff
Signal [|||||]

1.800.338.7337 / www.soundoffsignal.com

Pg. 1

NOTICE:

Installers and users must comply with all applicable federal, state and local laws regarding use and installation of warning devices.

Improper use or installation may void warranty coverage.

To review our Limited Warranty Statement & Return Policy for this or any SoundOff Signal product, visit our website at www.soundoffsignal.com/tech-services/returns/.

If you have questions regarding this product, contact **Technical Services**, Monday - Friday, 8 a.m. to 5 p.m. ET at 1.800.338.7337 (press #4).

Questions or comments that do not require immediate attention may be emailed to techservices@soundoffsignal.com.

ENHANCING SAFETY THROUGH INNOVATION

CAUTION

Some vehicle manufacturers may NOT allow the use of this product on vehicles that they manufacture. Please consult your operator's manual, prior to installation. Also, make sure you fully read and understand all instructions before attempting to install the Flashback Flasher. The SoundOff Signal® 100% Solid State ETTFK02 Flashback module has the isolating diodes for the reverse wire that is now required by many new cars and trucks. This module is intended to be used on vehicles that have the negative post of the battery connected to the chassis of the vehicle. A properly installed flashback will alternately flash the brake lights and the reverse lights at a rate of 2.4 flashes per second. Alternating red and white light creates an effective warning signal to the rear of the vehicle to greatly reduce rear end collisions.

INSTALLATION MOUNTING:

- For vehicles with a trunk: mount the flashback as close to the driver side taillight housing as possible.
- For vehicles with a tailgate or lift gate: mount the flasher as close to the taillight housing on the driver side.
- For pickup trucks: remove the driver side taillight housing and mount the flasher behind the taillight housing.

CONNECTIONS:

1. Extend the WHITE WIRE from the module using 14 gauge wire. This wire must go all the way to the battery. Use 18 gauge or larger wire to extend any other wires, as needed.
2. Connect the GREEN WIRE to a convenient reliable ground.
3. Connect the BROWN WIRE to a customer supplied 12V switch for activation of flasher.
4. Connect a fuse holder to the positive post of the battery. The fuse holder must be rated at 20 amps or greater.

NOTE: Do not install the fuse until all other connections have been completed.

5. Connect the 14 gauge extension wire to the fuse holder.

NOTE: Failure to extend the WHITE wire to the battery with 14 gauge wire will result in improper operation and may cause damage to the flasher or other devices in the vehicle.

6. Plug flasher connection ends to the vehicle harness, an audible click ensures contacts are all latched.

FUNCTION:

- Ring ONLY
- Outer ring alternate with center ring
- Running lights and headlights: On will not override flasher

ETTFK02 0420

FLASHBACK™ ALTERNATING TAILLIGHT

ETTFK02 - 2010-2020 DODGE DURANGO TAILLIGHT FLASHER KIT WITH CONNECTORS ON EXIT WIRES & WIRE HARNESS

IMPORTANT: TEST VEHICLE SAFETY SYSTEMS AND FLASHER

1. Set emergency / parking brake and start the vehicle.
2. With Flasher OFF, attempt to shift the transmission out of PARK without depressing the brake. TRANSMISSION MUST NOT SHIFT. If the vehicle shifts from PARK, disconnect the Flasher, restore vehicle wiring and contact SoundOff Signal Technical Service Department for further instructions.
3. With Flasher ON, attempt to shift the transmission out of PARK without depressing the brake. TRANSMISSION MUST NOT SHIFT. If the vehicle shifts from PARK, disconnect the Flasher, restore vehicle wiring and contact SoundOff Signal Technical Support Department for further instructions.
4. Periodically have the operator of the vehicle repeat the above test to ensure proper operation of the vehicle safety systems.

Diagram for use with Plugs

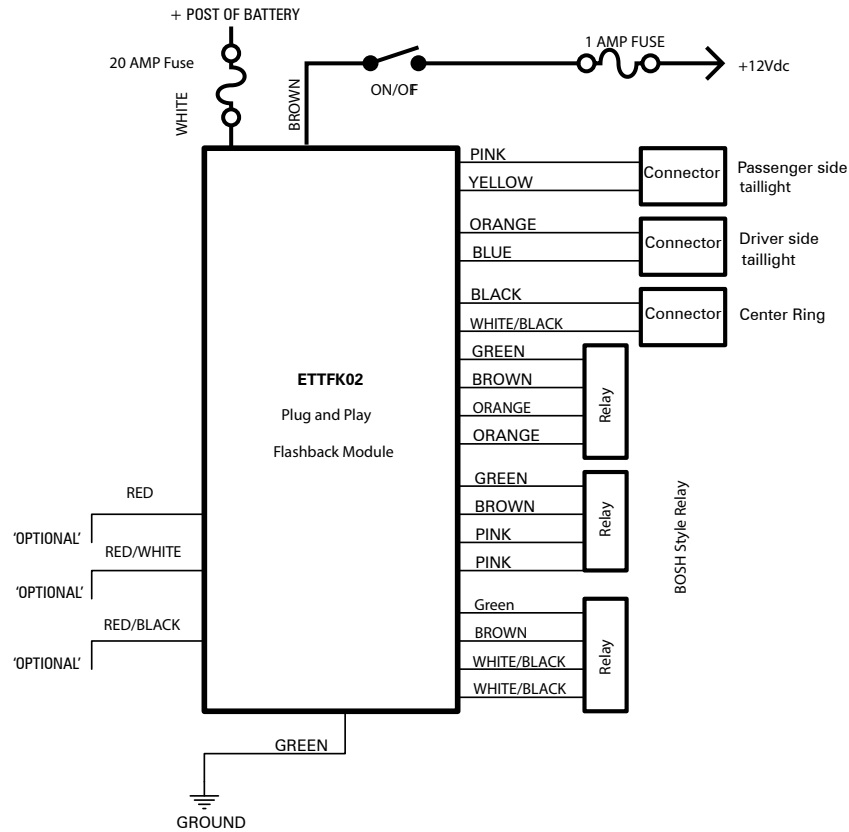
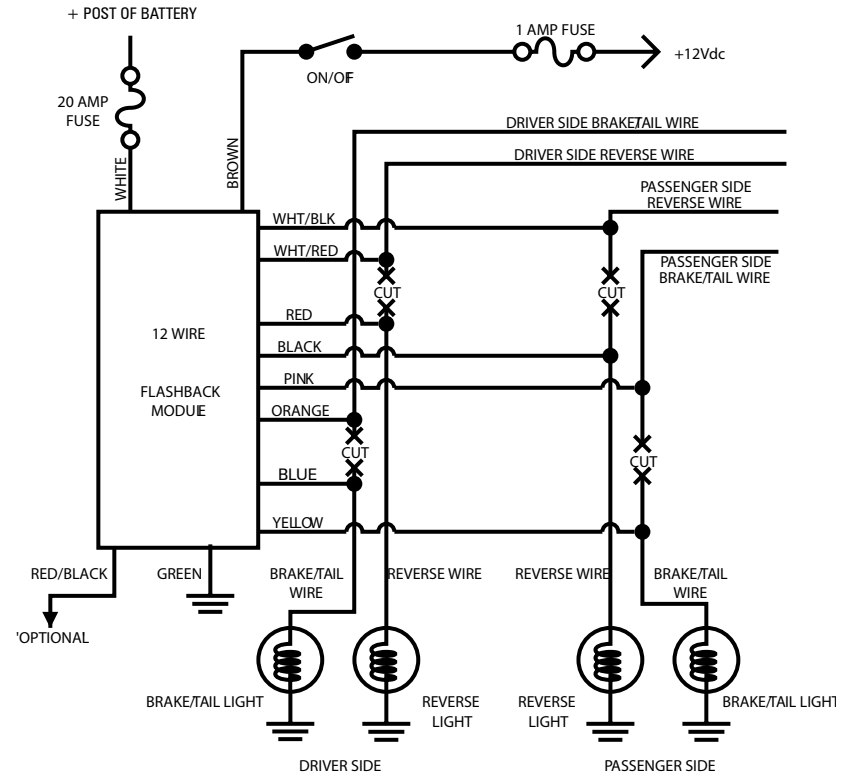

Diagram for use without Plugs



WARNING:
DO NOT Connect the ETTFK02 Taillight Flasher to the High Mounted-Stop Lamp (i.e. "Cyclops", "Center Light", "CHMSL"). Flashing the High Mounted Stop Lamp violates Federal Motor Vehicle Safety Standard (FMVSS) No. 108 which requires the High Mounted Stop Lamp only illuminate when applying the brakes.

ELECTRICAL SPECIFICATIONS	
Input Voltage	10-16Vdc
Output Current:	5 Amps / output
Standby Current:	< 10mA
Frequency:	2.4 f.p.s.