

# 100J/100U Series Speaker Bracket (No Drill) Ford F-150 Police Responder 2021-2023, Frame Mount

ETSSVBK14 -- Driver Side  
ETSSVBK15 -- Passenger Side

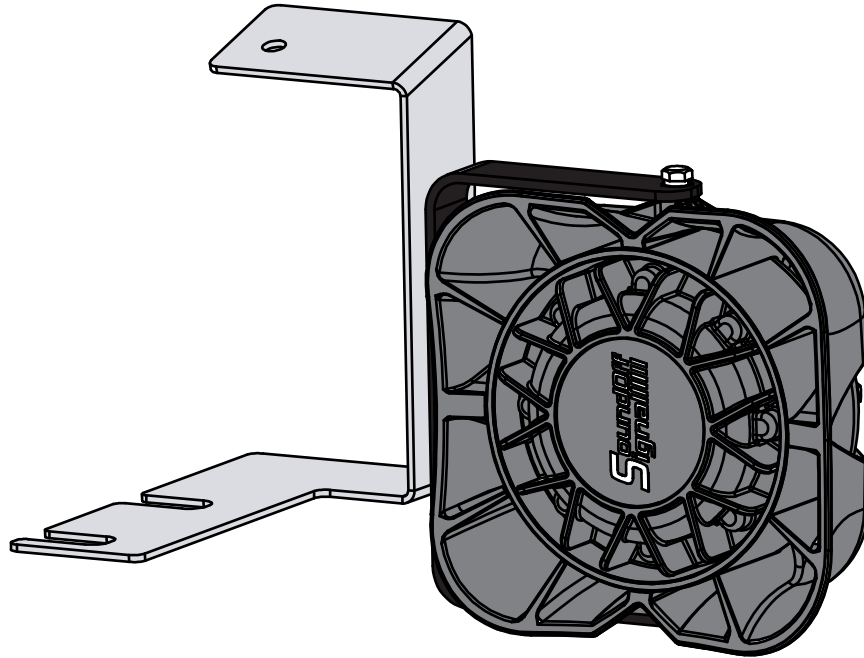

\*ETSSVBK14 shown with 100J Speaker, sold separately

## WARNING

- HIGH CURRENT interconnects must be properly terminated. Poor crimp quality can cause heat build-up and fire. Follow crimp connector manufacturer instructions.
- DO NOT install this product or route any wires in the Air Bag Deployment Zone. Refer to vehicle Owner's Manual for deployment zones.
- Do NOT use system to disconnect headlights, brake lights or other safety equipment.
- Unit may become hot to touch during normal operation.
- Failure to properly install connectors, fuses or wiring may cause vehicle failure or fire.
- Installation must only be performed by trained technician. Installer must determine vehicle wiring configuration and proper integration of system.
- Use proper wire gauge. All power wires connecting to positive (+) or negative (-) battery terminal or local chassis ground (-) must be sized to supply at least 125% of max. current and properly fused at power source.
- Install protective grommets when routing wire through firewall or metal.

INTRODUCTION..... 2  
COMPONENTS ..... 2  
INSTALLATION INSTRUCTIONS . . . . 2  
INSTALLATION IMAGES . . . . . 3

 **WARNING**

ROUTE WIRES ONLY IN LOCATIONS THAT ARE NOT SUBJECTED TO POTENTIAL WEAR. MAKE SURE TO AVOID ROUTING WIRES IN THE DEPLOYMENT AREA OF YOUR AIR BAG. REFER TO YOUR VEHICLE'S OWNER'S MANUAL FOR AIRBAG DEPLOYMENT ZONES.



100J Speaker Product Page



1.800.338.7337 / [www.soundoffsignal.com](http://www.soundoffsignal.com)

**NOTICE:**

Installers and users must comply with all applicable federal, state and local laws regarding use and installation of warning devices. *Improper use or installation may void warranty coverage. To review our Limited Warranty Statement & Return Policy for this or any SoundOff Signal product, visit our website at [www.soundoffsignal.com/tech-services/returns/](http://www.soundoffsignal.com/tech-services/returns/). If you have questions regarding this product, contact **Technical Services**, Monday - Friday, 8 a.m. to 5 p.m. ET at 1.800.338.7337 (press #4). Questions or comments that do not require immediate attention may be emailed to [techservices@soundoffsignal.com](mailto:techservices@soundoffsignal.com).*

# INTRODUCTION:

Thank you for purchasing the 2021-2023 Ford F-150 Police Responder High Frequency bracket kit.

Ford F-150 Police Responder high frequency speaker bracket features include:

- Compatible with 100J & 100U speakers\*
- Designed to hold one speaker
- Specific to driver or passenger side of vehicle
- Utilizes universal bail bracket provided with each high frequency speaker

100J Speaker features include:

- Designed for clear, powerful output using neodymium magnet
- Meets CA Title 13, Class A when used with SoundOff Signal siren amplifier
- Composite housing creates electrical isolation from vehicle chassis to extend product life
- Weather tested; glass reinforced nylon material will not corrode like a traditional aluminum speaker
- Includes universal bail bracket

100U Speaker features include:

- Clear, powerful, 100 watt output in compact, durable assembly
- Composite housing creates electrical isolation from vehicle chassis to extend product life
- Weather tested, reinforced nylon material will not corrode
- Improved design for passive water and moisture egress
- Includes universal bail bracket

CONTAINS		
ITEM #	COMPONENT	QTY.
1	HIGH FREQUENCY SPEAKER BRACKET	1
2	¼"-20 HEX HEAD BOLT	2
3	¼"-20 FLAT WASHER	4
4	¼"-20 NYLON LOCK NUT	2
5	PRODUCT WARNING CARD	1
6	INSTALLATION/INSTRUCTION SHEET	1
7	CA PROP 65 LABEL	1

Numbered components shown in **Fig. 4**  
\*Speaker and bail bracket sold separately

# INSTALLATION:

1. Removing the front fascia of the vehicle is recommended, but not necessary, in order to access the mounting location for the speaker bracket. This bracket mounts the speaker in front of the wheel on the side of the frame rail. Consult a Ford service center for best disassembly method. Keep all hardware.
2. Identify the mounting location of the speaker bracket on the frame of the vehicle, as shown in **Fig. 1**.
3. Loosen the fasteners (2) attaching the tow hook to the frame of the vehicle, as shown in **Fig. 2**.
4. Remove the fastener on the upper part of the frame, as shown in **Fig. 3**. Set aside for reassembly.
5. Attach a compatible speaker and bail bracket to the speaker bracket using the provided ¼"-20 hex bolts and nuts, as shown in **Fig. 4**. Tighten to 10 ft-lbs.
6. Install the speaker bracket assembly onto the frame. Slide the bracket over the frame rail and line up the fastener holes (3) on the bracket with the mounting locations on the frame.
7. Reinstall the single fastener on the upper part of the frame. Tighten to manufacturer's specifications.
8. Insert the tow hook fasteners (2) through the tow hook and the mounting holes on the lower portion of the bracket. The flange of the speaker bracket should be sandwiched between the tow hook and the frame. Tighten to manufacturer's specifications.
9. Ensure that the speaker is connected to a siren speaker output source. Check proper functionality.
10. Reinstall the front fascia according to the manufacturer's specifications.

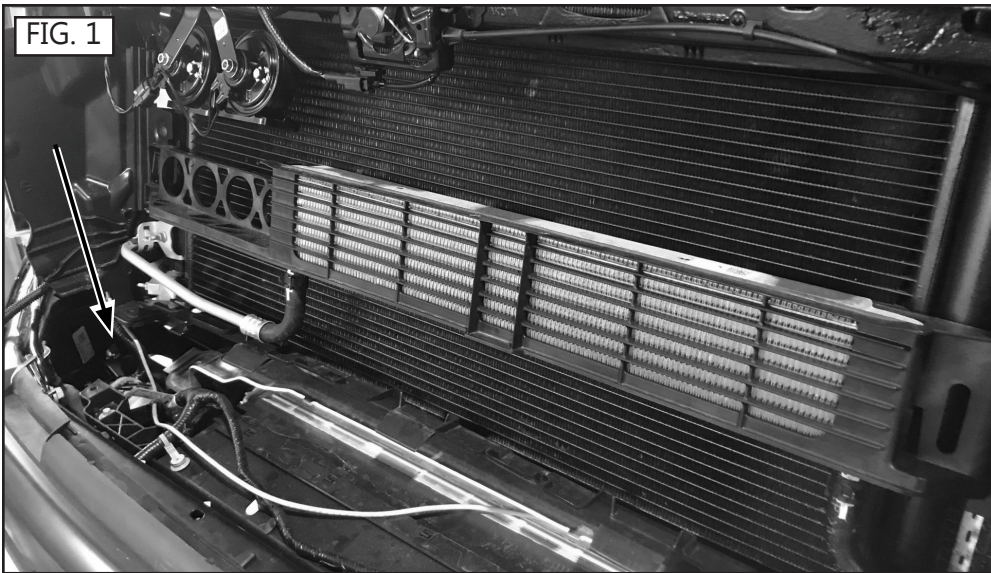

←  
**NOTE:** VEHICLE SHOWN WITH GRILLE REMOVED. ARROW INDICATES MOUNTING LOCATION ON FRAME OF PASSENGER SIDE SPEAKER BRACKET.

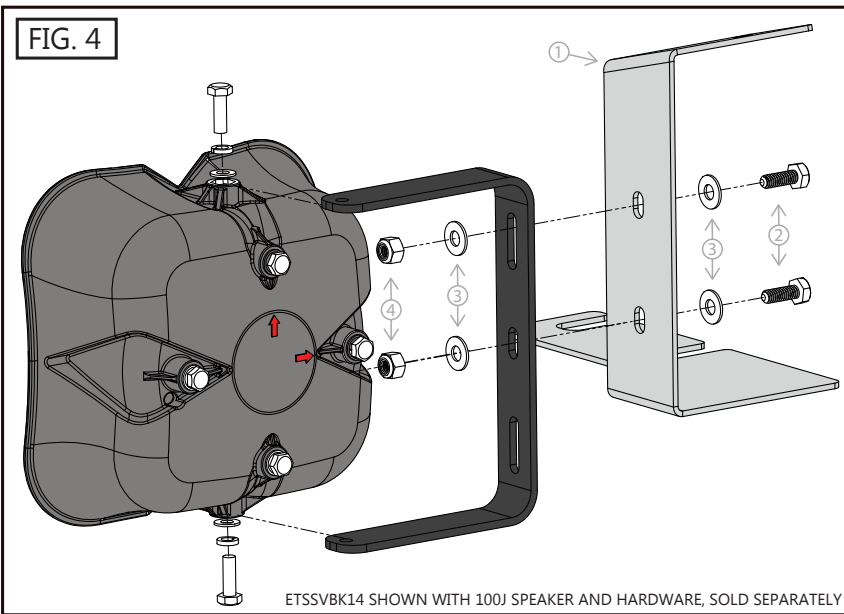
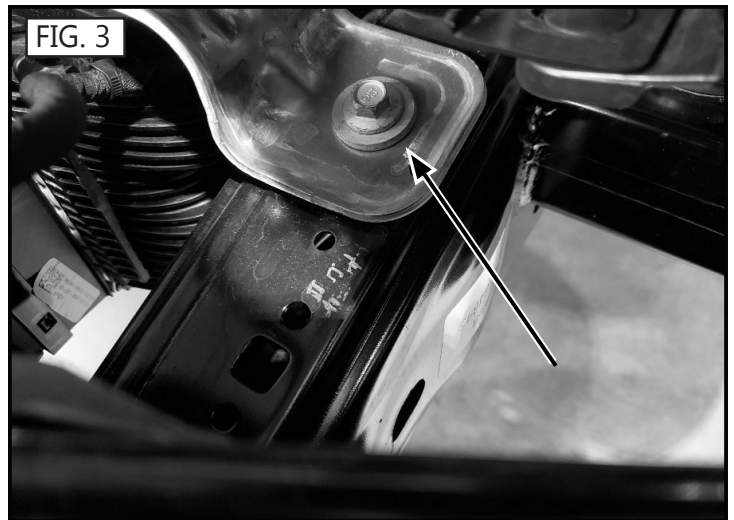
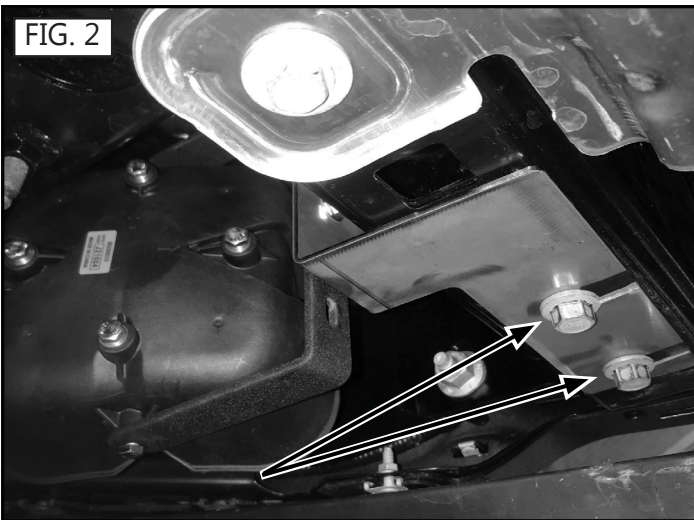

**NOTE:** 100U SPEAKERS NEED TO BE INSTALLED WITH ARROWS ON BACK OF SPEAKER POINTING DOWN ↓ & 100J SPEAKERS MUST HAVE THE ARROWS POINTING UP ↑.