

100J/100U SERIES SPEAKER BRACKET (NO DRILL) CAPABLE OF HOLDING UP TO TWO SPEAKERS FOR DODGE RAM 1500 (5TH GENERATION ONLY) 2019 - 2023, HOOD LATCH MOUNT

ETSSVBK12

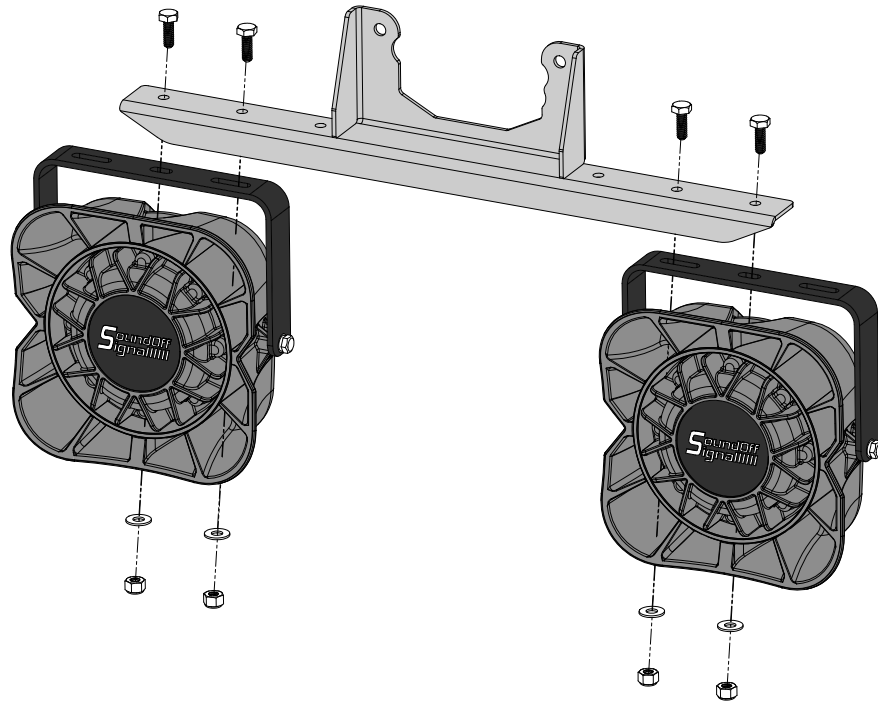

SHOWN WITH 100J SPEAKERS, SOLD SEPARATELY

⚠ WARNING

- HIGH CURRENT interconnects must be properly terminated. Poor crimp quality can cause heat build-up and fire. Follow crimp connector manufacturer instructions.
- DO NOT install this product or route any wires in the Air Bag Deployment Zone. Refer to vehicle Owner's Manual for deployment zones.
- Do NOT use system to disconnect headlights, brake lights or other safety equipment.
- Unit may become hot to touch during normal operation.
- Failure to properly install connectors, fuses or wiring may cause vehicle failure or fire.
- Installation must only be performed by trained technician. Installer must determine vehicle wiring configuration and proper integration of system.
- Use proper wire gauge. All power wires connecting to positive (+) or negative (-) battery terminal or local chassis ground (-) must be sized to supply at least 125% of max. current and properly fused at power source.
- Install protective grommets when routing wire through firewall or metal.

NOTICE:

Installers and users must comply with all applicable federal, state and local laws regarding use and installation of warning devices.

Improper use or installation may void warranty coverage.

To review our Limited Warranty Statement & Return Policy for this or any SoundOff Signal product, visit our website at www.soundoffsignal.com/tech-services/returns/.

If you have questions regarding this product, contact **Technical Services**, Monday - Friday, 8 a.m. to 5 p.m. ET at 1.800.338.7337 (press #4).

Questions or comments that do not require immediate attention may be emailed to techservices@soundoffsignal.com.

INTRODUCTION:

100J Speaker* Features:

- Designed for clear, powerful output using neodymium magnet
- Meets CA Title 13, Class A when used with SoundOff Signal siren amplifier
- Composite housing creates electrical isolation from vehicle chassis to extend product life
- Weather tested, glass reinforced nylon material will not corrode like a traditional aluminum speaker
- Includes universal bail bracket Design highlights for this vehicle-specific speaker bracket assembly:
- Holds up to two speakers
- Utilizes universal bail bracket provided with each speaker

CONTAINS

ITEM#	COMPONENT	QTY
1	SPEAKER BRACKET	1
2	¼"-20 HEX HEAD BOLT	4
3	¼"-20 LOCK NUT	4
4	¼" FLAT WASHER	4
5	INSTALLATION INSTRUCTION SHEET	1
6	PRODUCT WARNING CARD	1
7	CA PROP 65 LABEL	1

*Speaker and bail bracket sold separately

**Hardware provided to attach up to two speakers

BRACKET COMPATIBLE WITH SPEAKERS:

**-100J
-100U**



1.800.338.7337 / www.soundoffsignal.com

100J/100U SERIES SPEAKER BRACKET (NO DRILL) CAPABLE OF HOLDING UP TO TWO SPEAKERS FOR DODGE RAM 1500 (5TH GENERATION ONLY) 2019 - 2023, HOOD LATCH MOUNT

ETSSVBK12

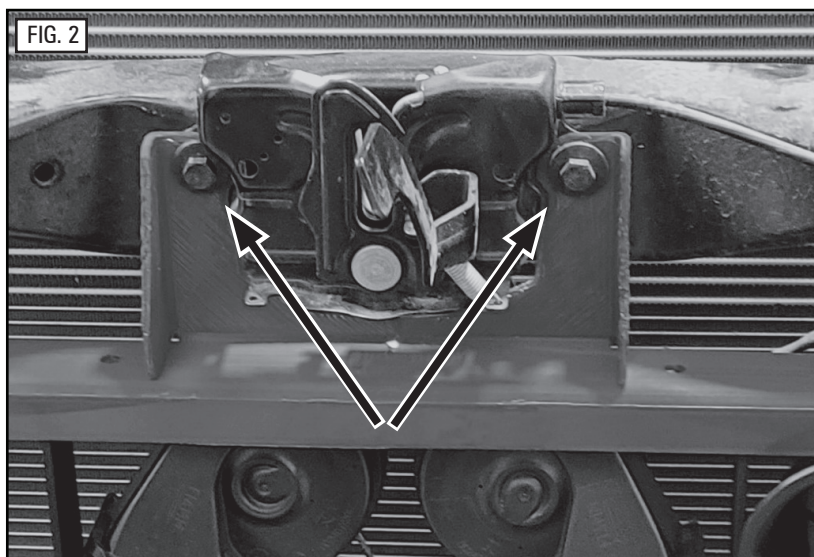
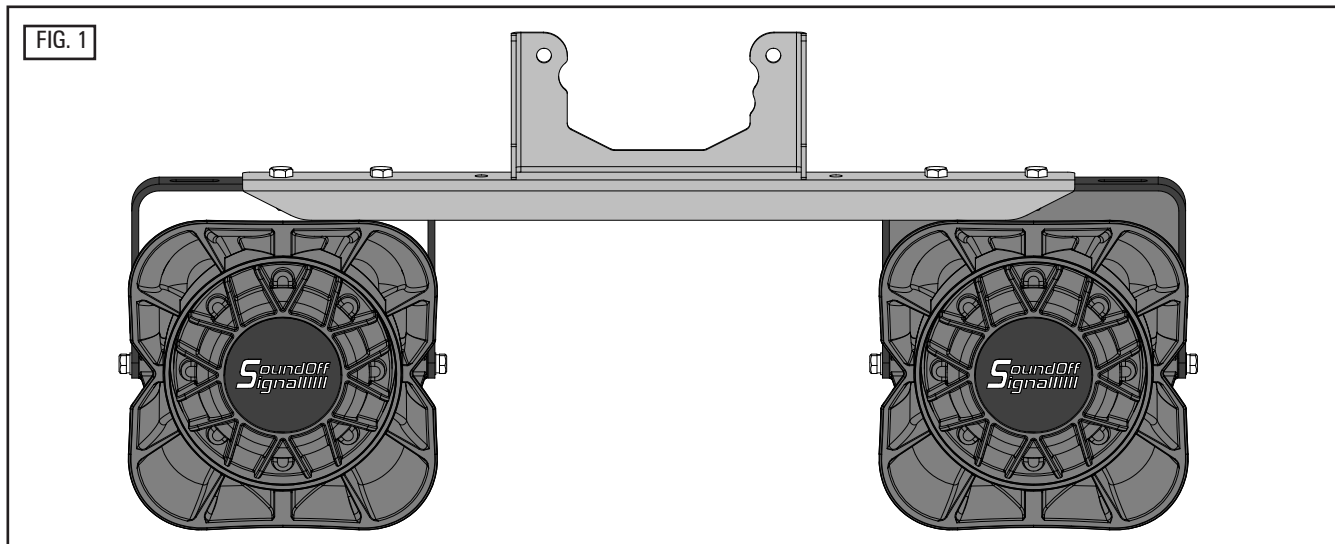

INSTALLATION:

1. This speaker bracket utilizes the two existing fasteners for the hood latch mechanism. With the hood open, remove the shield covering the area between the radiator and the grille. Next, remove the front grille and the louvers of the vehicle in order to access the space in front of the radiator for speaker bracket installation. Consult a Stellantis service center for best disassembly method. Keep all hardware.
2. Attach compatible speakers and bail brackets to the speaker bracket using the provided 1/4-20 hex bolts and nuts. Tighten to 10 ft-lb. The speaker bracket can hold a maximum of two speakers. See FIG.1 for mounting locations.
3. Locate and remove the two fasteners for the hood latch assembly, as shown in FIG.2.
4. With the hood latch assembly still in its original position, carefully insert the speaker bracket assembly into the space in front of the radiator. Attach the speaker bracket to the vehicle using the two hood latch assembly fasteners that were removed in Step 3. Ensure that the existing wire harness and hood latch release cable are properly routed in the bracket cutouts. Tighten to manufacturer's specifications.
5. Adjust each speaker so that the speakers are in-line with the bail brackets and do not contact the louvers or radiator. Tighten the fasteners attaching the speakers to the bail brackets in order to prevent the speaker from pivoting.
6. Ensure that the speakers are connected to a power source. Check proper functionality.
7. Reinstall the front grill, louvers, and the shield according to manufacturer's specifications.

NOTICE:

Installers and users must comply with all applicable federal, state and local laws regarding use and installation of warning devices.

Improper use or installation may void warranty coverage.

To review our Limited Warranty Statement & Return Policy for this or any SoundOff Signal product, visit our website at www.soundoffsignal.com/tech-services/returns/.

If you have questions regarding this product, contact **Technical Services**, Monday - Friday, 8 a.m. to 5 p.m. ET at 1.800.338.7337 (press #4).

Questions or comments that do not require immediate attention may be emailed to techservices@soundoffsignal.com.

SoundOff Signal

1.800.338.7337 / www.soundoffsignal.com