

100% SOLID STATE ALTERNATING ELECTRONIC FLASHER WITH TRANSORB

ROAD RUNNER S. S. (ETRRS0-P)

POWER PULSE S. S. (ETPPS0-P)

Congratulations! You are now the proud owner of the most technically advanced, true 100% Solid State Alternating Headlight Flasher System in the market today. Add to it our never ending commitment to quality, this new Flasher System will provide you with years of dependable, trouble free service.

The Road Runner S.S. or Power Pulse S.S. will operate a two or four headlight system on any vehicle with a 12 VDC negative ground system.*

NOTE

This Flasher will not work on any ground side switched system. If you have any questions regarding what type of system your vehicle has contact SoundOff Signal's Technical Support Department at 1-800-338-7337.

A properly installed Road Runner S.S. or Power Pulse S.S. will alternate the vehicles high beam lights at a constant flash rate (1.9 flashes per second for the Road Runner; 3.0 flashes per second for the Power Pulse). When used at night, the low beam headlights remain ON for proper illumination, while the high beams flash to gain attention and increase the vehicles visibility. When the dimmer switch is activated to high beam, the Flasher Systems 'High Beam Override' interrupts the flasher sequence to allow normal high beam function. Flashing automatically resumes when the dimmer switch is deactivated.

NOTE

Flashing Headlight and Taillight Systems are intended for us on approved vehicles ONLY. It is the responsibility of the user of these systems to insure compliance to any Federal, State or Municipal regulations which may apply.

INSTALLATION

MOUNTING: Mount the Flasher so that the maximum amount of air will flow across it, typically close to the battery at the front of the engine compartment.

GREEN WIRE: Connect to a convenient, reliable ground.

NOTE

Always connect the Green wire to ground FIRST when installing and disconnect LAST when removing!

BLUE & YELLOW WIRE: Locate the wire that supplies power to the passenger side high beam headlight. Cut this wire approximately 10" to 12" from the back of the headlight. Connect the Yellow wire to the lead that returns to the passenger side high beam. Connect the Blue wire to the other piece of cut wire (this will make the drivers side high beam flash).

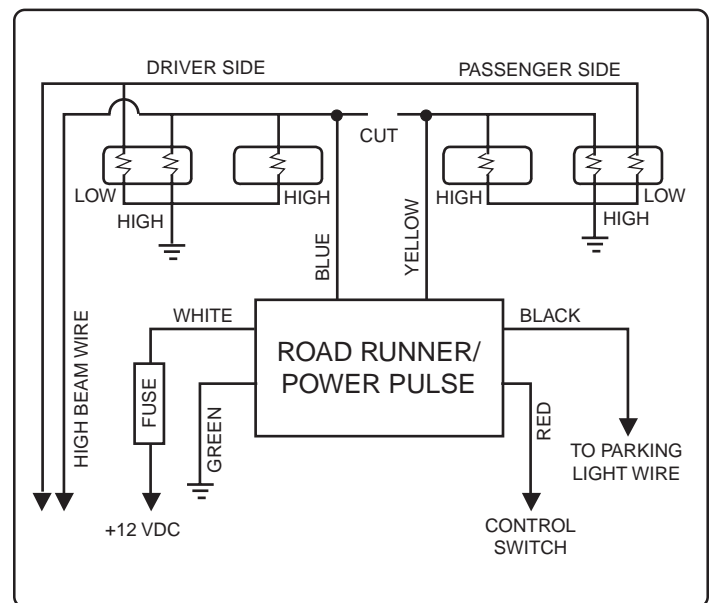

WIRING SCHEMATIC - 4 LAMP INSTALLATION

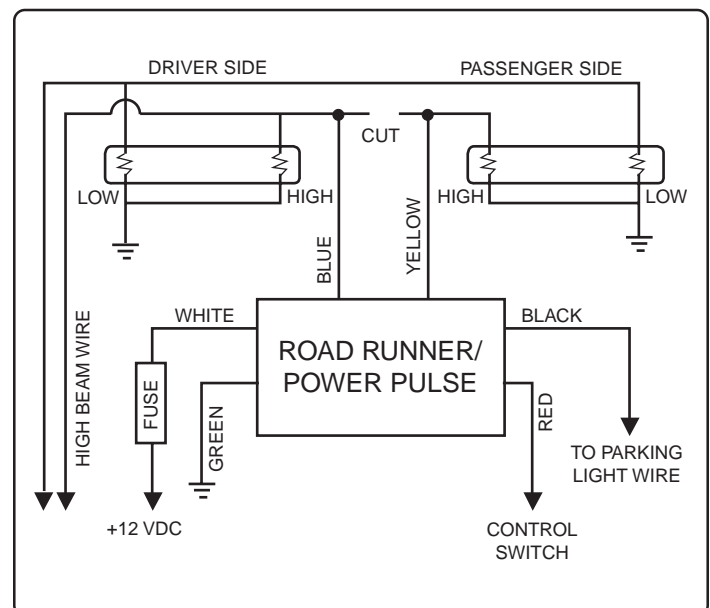

WIRING SCHEMATIC - 2 LAMP INSTALLATION

RED WIRE: Connect to a powered switch. This switch will only require 1/4 amp to activate the flasher.

WHITE WIRE: Connect through an ATO type fuse (20 amp) to the positive post of the battery. **DO NOT USE A CIRCUIT BREAKER, FUSIBLE LINK OR SLOW BLOW TYPE FUSE.**

NOTE

Older 4 bulb Sealed Beam Headlight Systems may require a 30 amp fuse. Call SoundOff Signal's Technical Support Department at 1-800-338-7337 for any further assistance.

NOTE

DO NOT connect the Red and White wires together. The White wire must receive a constant source of power at all times.

BLACK WIRE (OPTIONAL): If an "Automatic Nighttime Flasher Cutoff" is required (check State and Municipal regulations), simply "T" or tap the black wire into the parking light wire. If not required, connect the black wire to ground.

*We recommend no more than 12 amps per side to ensure maximum useful life.

WARRANTY

SoundOff Signal warrants the ETRRS0-P and ETPPS0-P Solid State Electronic Flasher Systems for five (5) years from the date of purchase to the original purchaser against any manufacturer defects or workmanship. This warranty applies only to units installed according to manufacturer's installation instructions and operated within the units specifications.

Warranty is void if the unit was installed incorrectly or maliciously damaged.

All warranty claims must be accompanied by a dated proof of purchase.

SoundOff Signal retains the right to be the sole mediator of what constitutes defects in performance or manufacturing.

Covered under U.S. Patents #4114071 and #4309639