

100% SOLID STATE HEAVY DUTY ALTERNATING ELECTRONIC FLASHER (ETHDF1-P)

NOTE

Contact SoundOff Signal when installing ground side switched headlights or series DRL headlight systems.

INSTALLATION

MOUNTING: Mount the flasher so that maximum amount of air will flow across it, typically in the front passenger side of engine compartment.

GREEN WIRE: Connect to a convenient reliable ground.

NOTE

Always connect the GREEN wire FIRST when installing and disconnect LAST when removing.

BROWN & BLUE/WHITE WIRES: Locate the wire that supplies power to the passenger side high beam. Cut this wire in-half, approximately 10" to 12" from the back of the headlight. Connect the BLUE/WHITE wire to the passenger side high beam. Connect the BROWN wire to the other half of the of cut wire. This wire returns to the driver's side high beam.

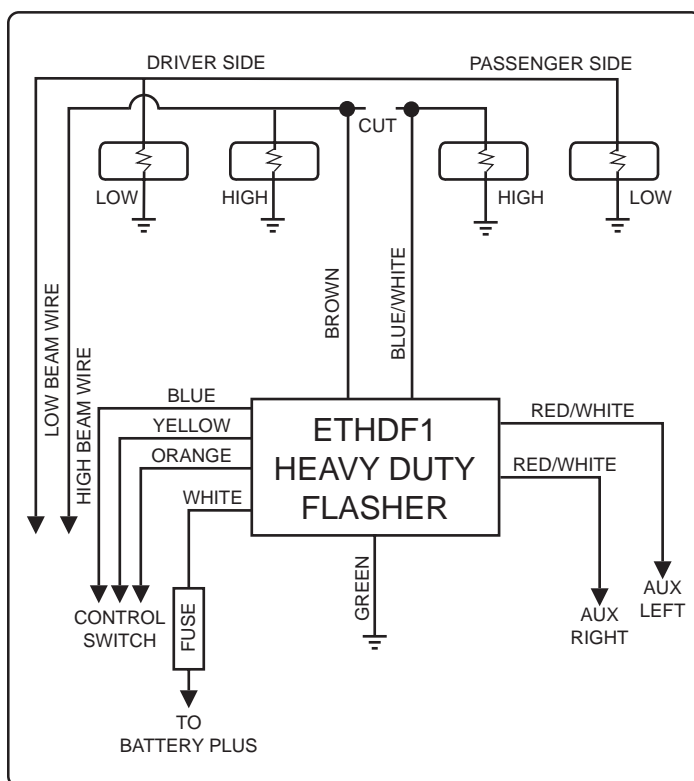

WIRING SCHEMATIC

WHITE WIRE: Connect to a reliable power source using a 30 amp in-line fuse.

YELLOW WIRE: Connect to a powered switch. This wire will turn the auxilliary flasher section to steady ON.

ORANGE WIRE: Connect to powered switch. This wire will turn the high beam lights steady ON.

NOTE: Orange wire is connected to Brown wire internally.

RED/WHITE WIRE(s): Connect to auxilliary light(s).

BLUE WIRE: Connect to a powered switch. This wire will activate the headlight & auxilliary flasher section.

DO NOT CONNECT THE FLASHER SYSTEM TO A CIRCUIT BREAKER OR FUSIBLE LINK !!!

NOTE

Do not connect the WHITE and YELLOW wires together. The WHITE wire must receive a constant source of power at all times.

WARRANTY

SoundOff Signal warrants this Solid State Electronic Flasher Systems for 5 years from date of purchase, to the original purchaser, against any manufactured defects or workmanship. This warranty applies only to units installed according to manufacturer's installation instructions and operated within the units specifications.

SoundOff Signal's obligation under this warranty is limited to repairing or exchanging the unit. Exchanging units under this warranty is as follows: 100% of purchase price for the first two years, 75% of purchase price the 3rd year, 50% of purchase price the 4th year, and 25% of purchase price the 5th year.

Warranty is void if the unit was installed incorrectly or maliciously damaged. All warranty claims must be accompanied by a dated proof of purchase.

SoundOff Signal retains the right to be the sole mediator of what constitutes defects in performance or manufacturing.