

FLASHBACK™ TAILLIGHT FLASHER

ETFB00-P (with wires)

ETFBFLEE (with Amp Connector and Fleet Harness)

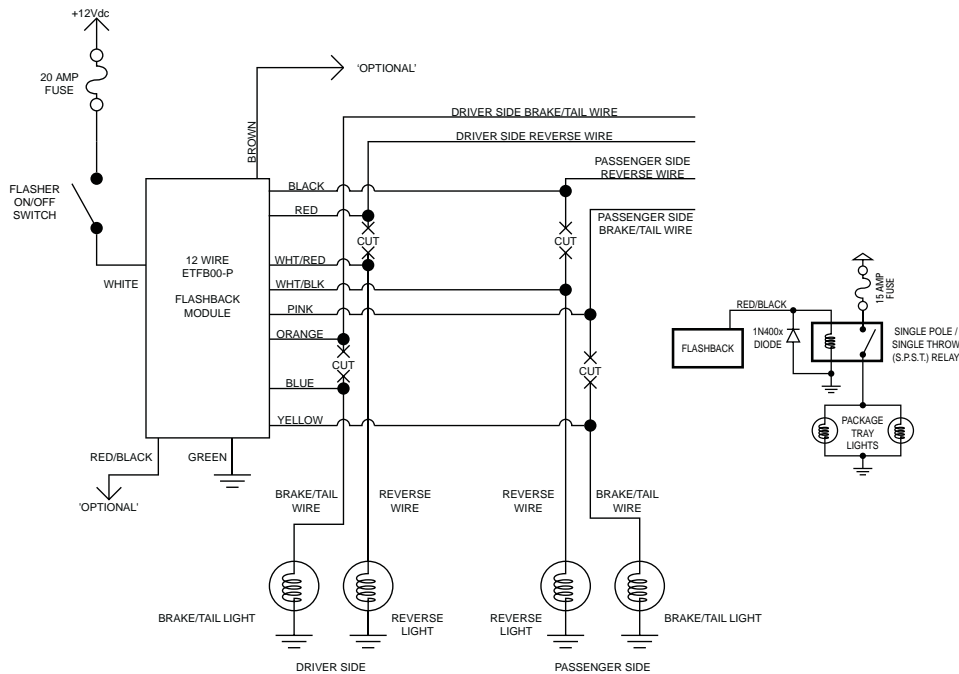

NOTE: FOR VEHICLES THAT REQUIRE BLOCKING DIODES IN THE REVERSE WIRE, USE OF THE ETFB00-P (12 WIRE) FLASHBACK PROVIDES THE BLOCKING DIODES INTERNALLY.

Please see reverse for Technical Specifications

Important Information:

- Warning devices are strictly regulated and governed by Federal, State and Municipal ordinances. These devices shall be used ONLY on approved vehicles. It is the sole responsibility of the user of these devices to ensure compliance.
- DO NOT install this product or route any wires in the Air Bag Deployment Zone. Refer to your vehicle Owner's Manual for the location of any air bag deployment zones.
- DO NOT connect this device to a strobe power supply. This product is self-contained and does not require an external power supply.



CAUTION

Some vehicle manufacturers may not allow the use of this product on vehicles they manufacture. Please consult your operator's manual prior to installation. Also, make sure you fully read and understand all instructions before attempting to install the Flashback Flasher.

The SoundOff Signal Solid State driven relay model ETFB00-P 12 wire Flashback module now has the isolating diodes for the reverse wire that is now required by many new cars and trucks. This module is intended to be used on vehicles that have the negative post of the battery connected to the chassis of the vehicle.

A properly installed flashback will alternately flash the brake lights and the reverse lights at a rate of 2.4 flashes per second. Alternating red and white light creates an effective warning signal to the rear of the vehicle to greatly reduce rear end collisions.

INSTALLATION

MOUNTING: For vehicles with a trunk, mount the Flashback as close to the driver side taillight housing as possible. For vehicles with a tailgate or lift gate, mount the flasher as close to the taillight housing on the driver side. For pickup trucks, remove the driver side taillight housing and mount the flasher behind the taillight housing.

CONNECTIONS: Connect the green wire to a convenient reliable ground.

Extend the White wire from the module using 14 gauge wire. This wire will be connected to the switch that will turn the flasher on and off. The switch must be rated at 20 amps or greater. The fuse holder must be rated at 20 amps or greater.

NOTE: DO NOT INSTALL THE FUSE UNTIL ALL OTHER CONNECTIONS HAVE BEEN COMPLETED.

Use 18 gauge or larger wire to extend any other wires as needed.

Driver Side Connections:

Locate and cut the brake light wire. Connect the BLUE wire from the flasher to the end that goes to the brake light. Connect the ORANGE wire from the flasher to the end that goes to the front of the vehicle.

Locate and cut the reverse light wire. Connect the WHITE/RED wire from the flasher to the end that goes to the reverse light. Connect the RED wire from the flasher to the end that goes to the front of the vehicle.

Passenger Side Connections:

Extend the YELLOW, PINK, WHITE/BLACK and BLACK wire over to the passenger side of the vehicle.

Locate and cut the brake light wire. Connect the YELLOW wire from the flasher to the end that goes to the brake light. Connect the PINK wire from the flasher to the end that goes to the front of the vehicle.

Locate and cut the reverse light wire. Connect the WHITE/BLACK wire from the flasher to the end that goes to the reverse light. Connect the BLACK wire from the flasher to the end that goes to the front of the vehicle.

BROWN WIRE (OPTIONAL): Connect to deck lights to flash at the same time as the backup lights. Use of this option is preferred by many departments across the U.S., although use of this circuit may reduce the life of the flashback.

RED / BLACK: See schematic at left.

To review our Limited Warranty Statement & Return Policy for this or any SoundOff Signal product please visit our website at www.soundoffsignal.com and select the "Warranty & Returns" link along the left column of our home page. If you have questions regarding this product please contact Technical Services, Monday - Friday, 8 am to 5 pm at 1.800.338.7337, press #4 to skip the automated message. Questions or comments that do not require immediate attention may be emailed to techsupport@soundoffsignal.com.

1.800.338.7337. / www.soundoffsignal.com / Thank you for trusting us with your safety!

FLASHBACK™ TAILLIGHT FLASHER

ETFB00-P (with wires)

ETFBFLEE (with amp connector and fleet harness)

TECHNICAL SPECIFICATIONS	
Overall Dimensions:	2.16"H x 2.77"W x 3.22"D
Flash Frequency:	2.4 flashes per second
Input Voltage:	10-16Vdc
Output Current:	5 Amps/Output

IMPORTANT

Test Vehicle Safety Systems and Flasher

1. Set emergency / parking brake and start vehicle.
2. With Flasher OFF, attempt to shift transmission out of PARK without depressing the brake. TRANSMISSION MUST NOT SHIFT. If vehicle shifts from Park, disconnect the flasher, restore vehicle wiring and contact SoundOff Signal Technical Department for further instructions.
3. With Flasher ON, attempt to shift transmission out of PARK without depressing the brake. TRANSMISSION MUST NOT SHIFT. If vehicle shifts from Park, disconnect the flasher, restore vehicle wiring and contact SoundOff Signal Technical Department for further instructions.
4. Periodically have the operator of the vehicle repeat the above test to ensure proper operation of vehicle safety systems.

WARNING

DO NOT connect the Flashback™ Taillight Flasher to the High Mounted Stop Lamp (i.e. "Cyclops", "Center Light", "CHMSL"). Flashing the High Mounted Stop Lamp violates Federal Motor Vehicle Safety Standard (FMVSS) No. 108 which requires the High Mounted Stop Lamp ONLY illuminate when applying the brakes.

NOTE

On certain vehicles, when both the flashback and turn signals are operated together, the front signal may flash at a nonuniform rate. This condition causes no damage to either the vehicle or the flasher.

