

ALTERNATING REAR FLASHER

FLASHBACK (ETFB00-4)

CAUTION

Some vehicle manufacturers may not allow the use of this product on vehicles they manufacture. Please consult your operator's manual prior to installation. Also, make sure you fully read and understand all instructions before attempting to install the Flashback Flasher.

The ETFB00-4 utilizes the existing brake and turn signal lights on any vehicle with a 12 Vdc negative ground system. A properly installed Flashback will alternate the brake lights, ****EXCLUDING the third brake light, with the brake lights at a constant rate of 2.4 flashes per second.** Alternating red and yellow light creates an effective warning signal to the rear of the vehicle to greatly reduce rear end collisions.

MOUNTING: Mount in the vehicle's trunk near the brake lights.

CONNECTIONS: Use 18 gauge wire on all extensions except the white wire where 16 gauge wire is recommended.

GREEN WIRE: Connect to a convenient reliable ground.

8-PIN CONNECTOR: Plug into mating harness.

BROWN WIRE: Connect to switch to activate flashing.

WHITE WIRE: Connect through a 10Amp fuse directly to the positive post of the battery or other high current power source. We recommend the use of a fuse **ONLY - DO NOT CONNECT THE FLASHER SYSTEM TO A CIRCUIT BREAKER OR FUSIBLE LINK.**

IMPORTANT

TEST: Vehicle Safety Systems and Flasher

1. Set emergency / parking brake and start vehicle.
2. With Flasher OFF, attempt to shift transmission out of PARK without depressing the brake. TRANSMISSION MUST NOT SHIFT. If vehicle shifts from Park, disconnect the flasher, restore vehicle wiring and contact SoundOff Signal Technical Department for further instructions.
3. With Flasher ON, attempt to shift transmission out of PARK without depressing the brake. TRANSMISSION MUST NOT SHIFT. If vehicle shifts from Park, disconnect the flasher, restore vehicle wiring and contact SoundOff Signal Technical Department for further instructions.
4. Periodically have the operator of the vehicle repeat the above test to ensure proper operation of vehicle safety systems.

WARNING

DO NOT connect the ETFB00 Taillight Flasher to the High Mounted Stop Lamp (i.e. "Cyclops", "Center Light", "CHMSL"). Flashing the High Mounted Stop Lamp violates Federal Motor Vehicle Safety Standard (FMVSS) No. 108 which requires the High Mounted Stop Lamp **ONLY** illuminate when applying the brakes.

NOTE

On certain vehicles, when both the flashback and turn signals are operated together, the front signal may flash at a nonuniform rate. This condition causes no damage to either the vehicle or the flasher.

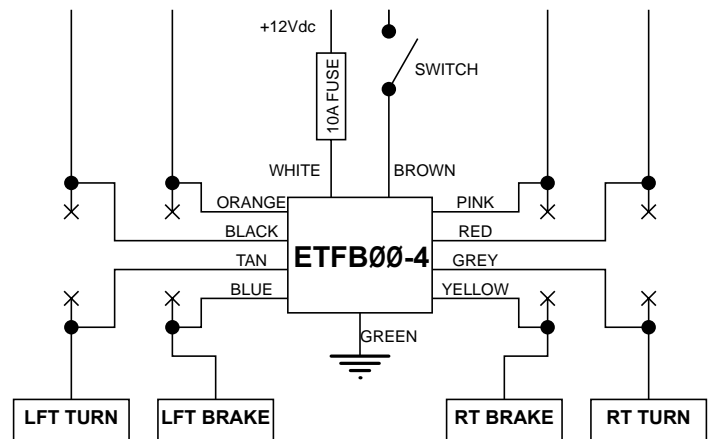
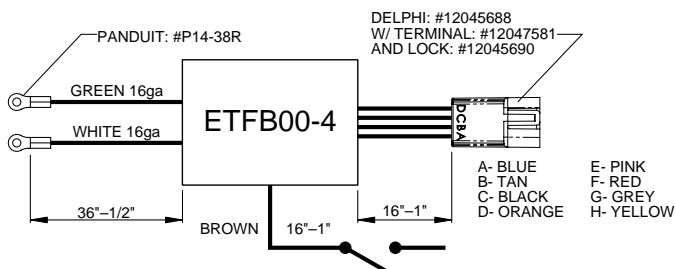

WARRANTY

SoundOff Signal warrants the ETFB00-4 Flasher Systems for One (1) year from the date of purchase to the original purchaser against any manufactured defects or workmanship. This warranty applies only to units installed according to manufacturer's installation instructions and operated within the units specifications, exclusive of the relay.

Warranty is void if the unit was installed incorrectly or maliciously damaged.

All warranty claims must be accompanied by a dated proof of purchase.

SoundOff Signal retains the right to be the sole mediator of what constitutes defects in performance or manufacturing.

Covered under U.S. Patents #4114071, #4309639 and #4859988