

ALTERNATING ELECTRONIC FLASHER ETDTSS50

Congratulations! You are now the proud owner of the most technically advanced true 100% Solid State Alternating Flasher System in the market today. Add to it our never ending commitment to quality, this new flasher system will provide you with years of dependable trouble free service.

A properly installed ETDTSS50 will alternate a set of lights at a constant flash rate of 50 flashes per minute.*

INSTALLATION

MOUNTING: Mount the flasher in a convenient location.

GREEN WIRE: Connect to a convenient reliable ground.

NOTE

Always connect the green wire to ground **FIRST** when installing and disconnect **LAST** when removing!

BLUE AND YELLOW WIRE: Connect the blue wire to the HOT lead of one deck or grille light. Connect the yellow wire to the HOT lead of the other deck or grille light.

RED WIRE: Connect to a powered switch. This switch will only require 1/4 amp to activate the flasher.

WHITE WIRE: Connect through a fuse directly to the positive post of the battery or other high current power source. We recommend the use of a fuse **ONLY** - **DO NOT CONNECT THE FLASHER SYSTEM TO A CIRCUIT BREAKER OR FUSIBLE LINK.**

NOTE

Welding on **ANY** vehicle creates voltage spikes that may destroy this flasher system and void its warranty. Disconnect **ALL** connections before welding on the vehicle or frame or wait to install the flasher after welding is completed.

Ensure lights used are properly grounded. **DO NOT** rely on the mounting bolt alone for ground connection.

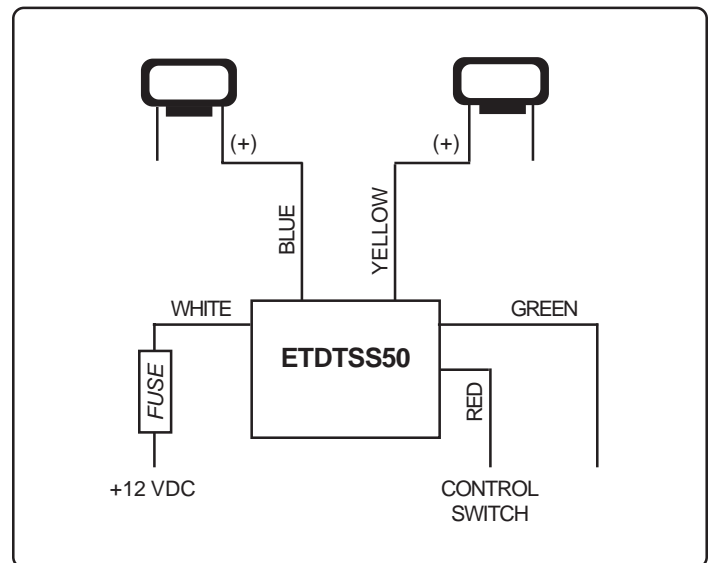

Wiring Schematic

WARRANTY

SoundOff Signal warrants the ETDTSS50 Solid State Electronic Flasher Systems for Five (5) years from the date of purchase to the original purchaser against any manufacturers defects or workmanship. this warranty applies only to units installed according to manufacturer's installation instructions and operated within the units specifications.

SoundOff Signal's obligation under this warranty is limited to repairing or exchanging the unit. Exchanging units under this warranty is as follows: 100% of purchase price for the first 2 years, 75% of the purchase price the 3rd year, 50% of the purchase price for the 4th year and 25% of the purchase price the 5th year.

Warranty is void if the unit was installed incorrectly or maliciously damaged.

All warranty claims must be accompanied by a dated proof of purchase.

SoundOff Signal retains the right to be the sole mediator of what constitutes defects in performance or manufacturing.

*We recommend no more than 5 amps per side to ensure maximum useful life.