

## 100% SOLID STATE ALTERNATING ELECTRONIC FLASHER EXTRA DUTY-15 AMP (ETAF15)

Congratulations! You are now the proud owner of the most technically advanced alternating flasher system in the market today. Add to it our never ending commitment to quality, this new flasher system will provide you with years of dependable, trouble free service.

A properly installed Extra Duty-15 Amp flasher will alternate up to fourteen 32 candle power lights at a constant flash rate of 1.9 flashes per second.

\*We recommend no more than 15 amps per side to ensure maximum useful life.

### INSTALLATION

**MOUNTING:** Mount the flasher so that maximum amount of air will flow across it.

**GREEN WIRE:** Connect to the ground post of battery.

### NOTE

Always connect the Green wire to ground **FIRST** when installing and disconnect **LAST** when removing!

**BLUE & YELLOW WIRES:** Connect the Blue wire to the hot lead(s) of a set of light(s), connect the Yellow wire to the hot lead(s) of another set of light(s).

**RED WIRE:** Connect to a powered switch (+12Vdc). This switch will only require 1/4 amp to activate the flasher.

**WHITE WIRE:** Connect through a 30 amp fuse directly to the Positive post of the battery or other high current power source. We recommend the use of a fuse only - **DO NOT CONNECT THE FLASHER SYSTEM TO A CIRCUIT BREAKER OR FUSIBLE LINK.**

### NOTE

Welding on ANY vehicle creates voltage spikes that may destroy this flasher system and void its warranty. Disconnect ALL connections before welding on vehicle or frame, or wait to install the flasher after welding is completed.

**Ensure lights used are properly grounded. Do not rely on mounting bolt alone for ground connection.**

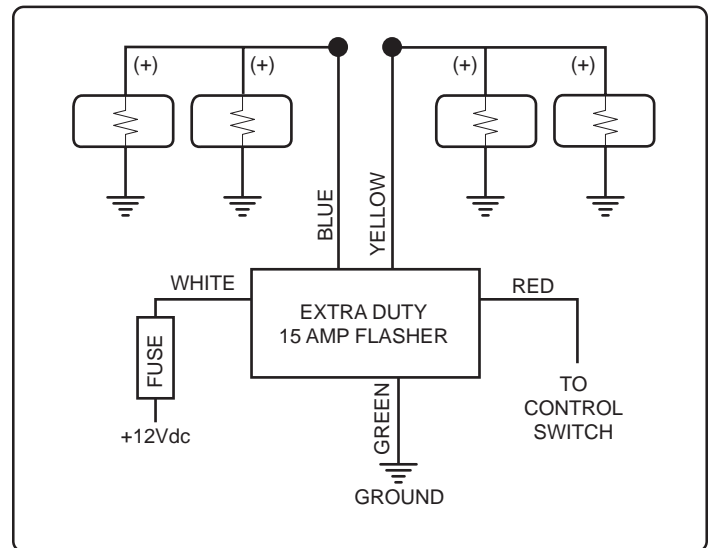

**WIRING SCHEMATIC**

### WARRANTY

SoundOff Signal warrants the ETAF15 solid state electronic flasher systems for 5 years from date of purchase, to the original purchaser, against any manufactured defects or workmanship. This warranty applies only to units installed according to manufacturer's installation instructions and operated within the units specifications.

Warranty is void if the unit was installed incorrectly or maliciously damaged.

All warranty claims must be accompanied by a dated proof of purchase.

SoundOff Signal retains the right to be the sole mediator of what constitutes defects in performance or manufacturing.