

100% SOLID STATE ALTERNATING ELECTRONIC FLASHER MEDIUM DUTY-8 AMP (ETAF08-P)

Congratulations! You are now the proud owner of the most technically advanced alternating flasher system in the market today. Add to it our never ending commitment to quality, this new flasher system will provide you with years of dependable, trouble free service.

A properly installed Medium-8 Amp flasher will alternate up to eight 32 candle power lights at a constant flash rate of 1.9 flashes per second.

INSTALLATION

MOUNTING: Mount the flasher so that maximum amount of air will flow across it.

GREEN WIRE: Connect to a convenient, reliable ground.

NOTE

Always connect the Green wire to ground **FIRST** when installing and disconnect **LAST** when removing!

BLUE & YELLOW WIRES: Connect the Blue wire to the hot lead(s) of a set of light(s), connect the Yellow wire to the hot lead(s) of the other set of light(s).

WHITE WIRE: Connect through a 20 amp fuse and a switch directly to the Positive post of the battery or other high current power source. We recommend the use of a fuse only - **DO NOT CONNECT THE FLASHER SYSTEM TO A CIRCUIT BREAKER OR FUSIBLE LINK.**

NOTE

Welding on ANY vehicle creates voltage spikes that may destroy this flasher system and void its warranty. Disconnect ALL connections before welding on vehicle or frame or wait to install the flasher after welding is completed.

*We recommend no more than 8 amps per side to ensure maximum useful life.

Ensure lights used are properly grounded. Do not rely on mounting bolt alone for ground connection.

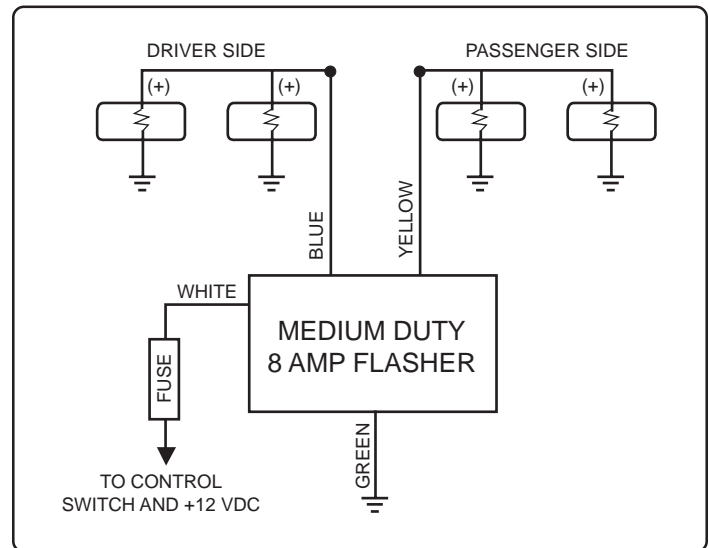

WIRING SCHEMATIC

WARRANTY

SoundOff Signal warrants the ETAF08 solid state electronic flasher systems for 5 years from date of purchase, to the original purchaser, against any manufactured defects or workmanship. This warranty applies only to units installed according to manufacturer's installation instructions and operated within the units specifications.

SoundOff Signal's obligation under this warranty is limited to repairing or exchanging the unit. Exchanging units under this warranty is as follows: 100% of purchase price for the first two years, 75% of purchase price the 3rd year, 50% of purchase price the 4th year, and 25% of purchase price the 5th year.

Warranty is void if the unit was installed incorrectly or maliciously damaged.

All warranty claims must be accompanied by a dated proof of purchase.

SoundOff Signal retains the right to be the sole mediator of what constitutes defects in performance or manufacturing.