

# PINNACLE

## Mini Lightbar

### EPL7100 MINI LIGHTBAR PERMANENT MOUNT

EPL71PD(xx) Low Bracket (shown)

EPL71HD(xx) High Bracket

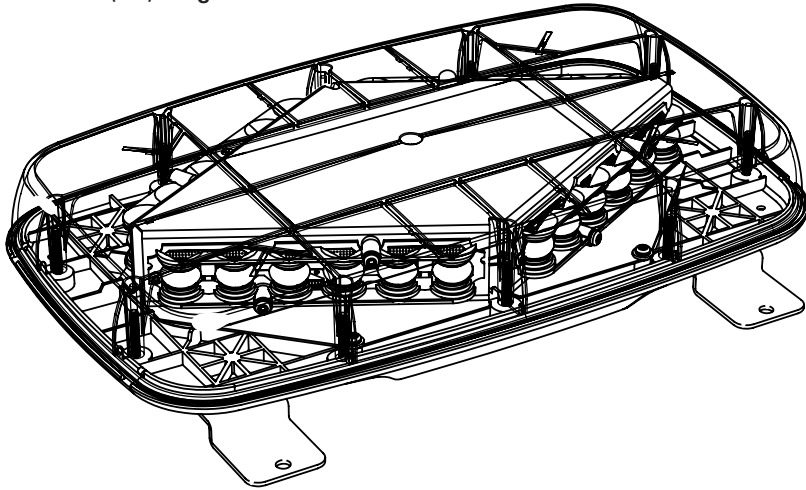

#### ⚠ WARNING

*Please see reverse for Technical Specifications*

- HIGH CURRENT interconnects must be properly terminated. Poor crimp quality can cause heat build-up and fire. Follow crimp connector manufacturer instructions.
- DO NOT install this product or route any wires in the Air Bag Deployment Zone. Refer to vehicle Owner's Manual for deployment zones.
- Do NOT use system to disconnect headlights, brake lights or other safety equipment.
- Unit may become hot to touch during normal operation.
- Failure to properly install connectors, fuses or wiring may cause vehicle failure or fire.
- Installation must only be performed by trained technician. Installer must determine vehicle wiring configuration and proper integration of system.
- Use proper wire gauge. All power wires connecting to positive (+) or negative (-) battery terminal or local chassis ground (-) must be sized to supply at least 125% of max. current and properly fused at power source.
- Install protective grommets when routing wire through firewall or metal.

**SoundOff**  
**Signal**  
Smart Design.

1.800.338.7337 / www.soundoffsignal.com

#### INSTALLATION:

- 1) Determine a clean, flat location (typically roof) on the vehicle to mount the PINNACLE Mini Lightbar. The PINNACLE Mini Lightbar comes with two (2) steel brackets which should be used to permanently mount the light bar to a vehicle roof or similar horizontal surface.
- 2) Position the bar with brackets attached and mark hole centers. Center punch or drill pilot holes for a 1/4" sheet metal screw (customer supplied).
- 3) Place a locking washer over the screw and securely fasten the brackets to the mounting surface. The screws and holes should be calked with a silicone based material to prevent leakage. **DO NOT OVERTIGHTEN!**
- 4) Make electrical connections.

**Caution:** Do not install this product or route any wires in the air bag deployment zone. Refer to your vehicle Owner's Manual for the location of any air bag deployment zones.

#### NOTICE:

Installers and users must comply with all applicable federal, state and local laws regarding use and installation of warning devices.

*Improper use or installation may void warranty coverage. To review our Limited Warranty Statement & Return Policy for this or any SoundOff Signal product, visit our website at [www.soundoffsignal.com/sales-support](http://www.soundoffsignal.com/sales-support). If you have questions regarding this product, contact **Technical Services**, Monday - Friday, 8 a.m. to 5 p.m. or after hours 5 p.m. to 8 p.m. EST at 1.800.338.7337 (press #4 to skip the automated message). Questions or comments that do not require immediate attention may be emailed to [techservices@soundoffsignal.com](mailto:techservices@soundoffsignal.com).*

SUPERIOR CUSTOMER RELATIONSHIPS. SMARTLY DESIGNED LIGHTING & ELECTRONIC SOLUTIONS.

#### ELECTRICAL CONNECTION:

Follow diagram below for electrical connections:

RED WIRE: Connect through a switch and fuse to 10-16Vdc.

BLACK WIRE: Connect to a good reliable ground (-).

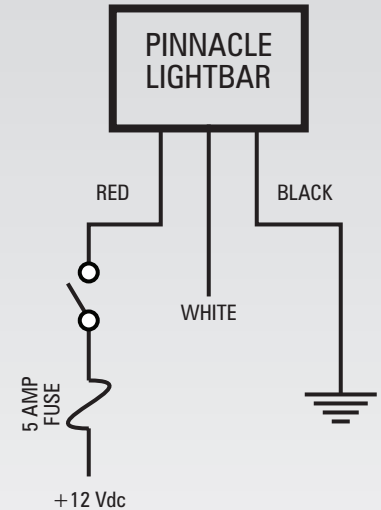

#### PATTERN CHANGE:

Connect BLACK WIRE to ground. Touch the WHITE WIRE to 10-16Vdc and hold for 1-2 seconds. The mini lightbar will advance one flash pattern and flash the new pattern each time this is done.

**⚠ WARNING**  
This product contains high intensity LED devices. To prevent eye damage, DO NOT stare into the light beam at close range.



## EPL7100 MINI LIGHTBAR PERMANENT MOUNT

EPL71PD(xx) Low Bracket (shown)

EPL71HD(xx) High Bracket

TECHNICAL SPECIFICATIONS	
Overall Dimensions:	14.25"L x 8.27"W x 2.93"H
Flash Patterns:	28 flash patterns
Input Voltage Range:	10 - 16 Vdc
Current Consumption:	2 Amps (Avg) - 4 Amps (Max)
# of LEDs:	24 Generation 3 LEDs
Operating Temperature:	-40° to +65° C

### Replacement Parts & Accessories:

- PMB3BKT Replacement Permanent Mount Bracket (each)
- PMB3BRKT Replacement Permanent Mount Bracket (kit)
- PMB3HBKT Replacement Permanent Mount Bracket - High Mount (each)
- PMB3HBRKT Replacement Permanent Mount Bracket (kit) - High Mount
- PMB3TD(x) EPL7000 Replacement Domes



Flash Patterns	
Alternating Patterns	FPM (Flashes per Minute)
1. Warp	Alternating
2. Quad	"
3. Quad2	"
4. Quint	"
5. Double2	"
6. Warp 1, 2, 3	"
7. Progressive	"
8. Q-Switch™	"
9. Intercycle	"
10. Warp	Whole Bar
11. Quad	"
12. Quad2	"
13. Quint	"
14. Double2	"
15. Warp 1, 2, 3	"
16. Progressive	"
17. Warp	Diagonal
18. Quad	"
19. Quad2	"
20. Quint	"
21. Double2	"
22. Warp 1, 2, 3	"
23. Progressive	"
24. Q-Switch	"
25. Intercycle	"
26. Rotator	"
27. Cycle 1	Random
28. Cycle 2	"