

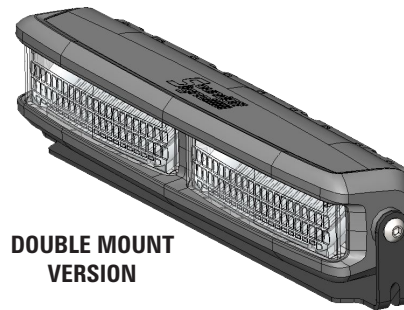

ECE-R65 CLASS 2 CERTIFIED DECK/ GRILLE MOUNT

ENFSGE(xx) - SINGLE DECK/GRILLE
 ENFDGE(xx) - DUAL DECK/GRILLE

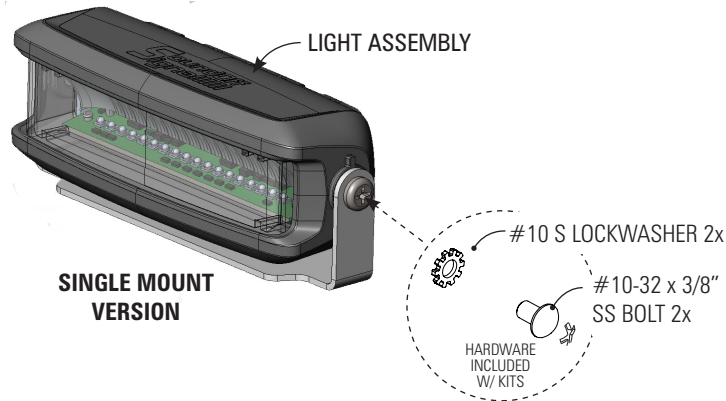

TECHNICAL SPECIFICATIONS	
DECK/ GRILL MOUNT nFORCE	
Single Mount Dimensions:	5.0"L x 1.88"H x 1.82"D
Double Mount Dimensions:	9.50"L x 1.88"H x 1.82"D
Input Voltage:	10 - 30 Vdc per module
CURRENT CONSUMPTION PER MODULE	
9 LED Single Color	< 1.6A @ 12.8 Vdc
	< 0.9A @ 25.6 Vdc

⚠ WARNING

- HIGH CURRENT interconnects must be properly terminated. Poor crimp quality can cause heat build-up and fire. Follow crimp connector manufacturer instructions.
- DO NOT install this product or route any wires in the Air Bag Deployment Zone. Refer to vehicle Owner's Manual for deployment zones.
- Unit may become hot to touch during normal operation.
- Failure to properly install connectors, fuses or wiring may cause vehicle failure or fire.
- Installation must only be performed by trained technician. Installer must determine vehicle wiring configuration and proper integration of system.
- Use proper wire gauge. All power wires connecting to positive (+) or negative (-) battery terminal or local chassis ground (-) must be sized to supply at least 125% of max. current and properly fused at power source.
- Install protective grommets when routing wire through firewall or metal.



1.800.338.7337 / www.soundoffsignal.com



NOTICE:

Installers and users must comply with all applicable federal, state and local laws regarding use and installation of warning devices.

Improper use or installation may void warranty coverage. To review our Limited Warranty Statement & Return Policy for this or any SoundOff Signal product, visit our website at www.soundoffsignal.com/sales-support. If you have questions regarding this product, contact **Technical Services**, Monday - Friday, 8 a.m. to 5 p.m. at **1.800.338.7337** (press #4 to skip the automated message). Questions or comments that do not require immediate attention may be emailed to techservices@soundoffsignal.com.

INSTALLATION:

- 1) Establish a flat position on the vehicle. Drill 3/16" holes in the center of the mounting locations. Note: 2 bolts are desired for the single mount and 4 bolts for the double mount attachments (not included with hardware kit). See page 4 for hole spacing.

INFORMATION FOR nFORCE SECONDARY:

WIRE HOOK-UP TABLE	
WIRE COLOR:	FUNCTION:
ORANGE OR RED	Power
BLACK	Ground
BLUE OR GREEN**	Sync2 *
YELLOW OR WHITE to GROUND	Wire Function -See page 2-
YELLOW OR WHITE to POWER	Function Wire
RED/WHITE OR ORANGE/WHITE	Power

- ** To sync multiple nFORCE lights, connect the Green and/or Blue wires from each light together.
- * Will NOT work w/ other sync products such as Ghost, LED3, & Intersector.

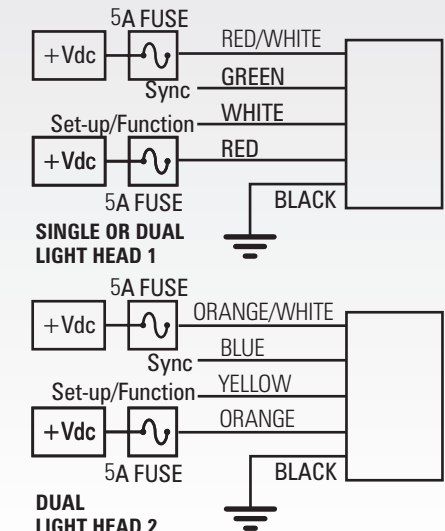



OVER-VOLTAGE PROTECTION

When an over-voltage condition is detected, the module will flash an over-voltage warning pattern of 50mS ON/950mS OFF to alert of the over-voltage condition and protect the electronics from damage due to heat/voltage.

THERMAL COMPENSATION PROTECTION

The LED module is designed to provide maximum power output while providing protection to the electronic components by reducing the output power at extreme temperatures.

SYNC 2

Synchronizing the flashing of multiple light modules is accomplished by connecting the Green and/or Blue wires of different light modules together. Up to 24 light modules can be connected for synchronized flashing. All light module flash patterns must be set to the same flash pattern # to ensure proper operation. Refer to the Sequence Type section in Set-Up Table to setup light modules to flash in alternate or simultaneous flash pattern. NOTE: Will NOT work with non-Sync 2 products such as Ghost, LED3, and Single Color Intersector.

PATTERNS	
NUMBER	NAME
1	SINGLE
2	DOUBLE
3	TRIPLE

FUNCTION TABLES

Changing the function table is only enabled when the LED module is in a flashing mode (disabled in cruise or steady ON functions). The functional operation of the LED module can be changed while applying the +V to the Red or Orange wire with the black wire connected to ground. When the light is flashing, momentarily connect the White or Yellow wire to ground for >4S and <5S (light will go steady high, steady low, off, steady high, steady low) then release. The function table will now advance to the next table (table 1 to table 2, table 2 to table 3, or table 3 to table 1). Repeat above process until required function table is active.

FUNCTION TABLE 1			
WIRE			LIGHT
RED (SGL) ORANGE (DUAL)	R/W (SGL) O/W (DUAL)	WHT (SGL) YELLOW (DUAL)	SINGLE
+12V			FLASH
	+12		CRUISE
+12V	+12V		FLASH
		+12V	NO OP
+12V		+12V	LOW PWR FLASH
	+12V	+12V	CRUISE
+12V	+12V	+12V	LOW PWR FLASH

FUNCTION TABLE 2			
WIRE			LIGHT
RED (SGL) ORANGE (DUAL)	R/W (SGL) O/W (DUAL)	WHT (SGL) YELLOW (DUAL)	SINGLE
+12V			FLASH
+12V		+12V	CRUISE
	+12V		STEADY CLR 1
	+12V	+12V	STEADY CLR 1
+12V	+12V	+12V	STEADY CLR 1
		+12V	NO OP

FUNCTION TABLE 3			
WIRE			LIGHT
RED (SGL) ORANGE (DUAL)	R/W (SGL) O/W (DUAL)	WHT (SGL) YELLOW (DUAL)	SINGLE
+12V			FLASH
	+12V		FLASH LOW PWR
+12V	+12V		FLASH LOW PWR
		+12V	NO OP
+12V		+12V	FLASH LOW PWR
	+12V	+12V	FLASH LOW PWR
+12V	+12V	+12V	FLASH LOW PWR





SIMULTANEOUS/ALTERNATE

This function can only be changed when the LED module is in a flashing mode (disabled in cruise or steady ON functions) and only has an effect when at least 2 LED modules have the green sync wire connected together. When the light is flashing, momentarily connect the white or yellow wire to ground for > 3S and < 4S (light will go steady high, steady low, off, steady high) then release. The light module will switch between Simultaneous and Alternate each time this sequence is done. To have light modules flash simultaneously, both light modules need to be set to the same sequence type (Set-Up Table). To have light modules flash alternately, the light modules need to be set to different sequence types (Set-Up Table).

ADVANCE PATTERN

Flash pattern can only be changed when the LED module is in a flashing mode (disabled in cruise or steady ON functions). When the light is flashing, momentarily connect the white or yellow wire to ground for > 250mS and < 1S (light will go steady high) then release. The flash pattern will advance to the next pattern. If the light module was at the last pattern, the pattern will reset to the 1st pattern.

BACKUP PATTERN

This function is only valid when the LED module is in a flashing mode (disabled in cruise or steady ON functions). When the light is flashing, momentarily connect the white or yellow wire to ground for > 1S and < 2S (light will go steady high, steady low) then release. The flash pattern will backup to the previous pattern. If the light module was at the first pattern, the pattern will change to the last pattern on the list.

PATTERN RESET

This function is only valid when the LED module is in a flashing mode (disabled in cruise or steady ON functions). When the light is flashing, momentarily connect the white or yellow wire to ground for > 5S and < 6S (light will go steady high, steady low, off, steady high, steady low, off) then release. The flash pattern will reset to the 1st pattern in the list.

FACTORY RESET

This function is only valid when the LED module is in a flashing mode (disabled in cruise or steady ON functions). When the light is flashing, momentarily connect the white or yellow wire to ground for > 6S and < 7S (light will go steady high, steady low, off, steady high, steady low, off, steady high) then release. The LED module will reset to: pattern=1, Function Table=1, Color Swap=OFF, Simultaneous.

SETUP TABLE			
SECONDS		USER INTERFACE	
FROM	TO	VISUAL FEEDBACK	ACTION TAKEN
0	1	STEADY-HIGH (60%)	FORWARD ONE PATTERN
1	2	STEADY-LOW (30%)	BACKWARD ONE PATTERN
2	3	OFF	NONE
3	4	STEADY - HIGH (60%)	SEQUENCE TYPE: SIMULTANEOUS OR ALTERNATE
4	5	STEADY - LOW (30%)	SEE FUNCTION TABLE
5	6	OFF	RESET TO PATTERN 1
6	7	STEADY-HIGH (60%)	FACTORY RESET (PATTERN 1, COLOR SWAP: OFF, SIMULTANEOUS) SEPARATE COLOR CONTROL: OFF

If held longer than 7 seconds, the light will go back to flashing the current pattern and no action will be taken.

BY NIGHT FEATURE:

- Reduced intensity for night time use
- Configure Light Module for Function Table 3
- Apply power to white wire for single lights. Apply power to white and yellow wire for dual lights.

BY DAY FEATURE:

- Standard intensity for day time use
- Leave white wire floating for single lights. Leave yellow wire floating for dual lights.



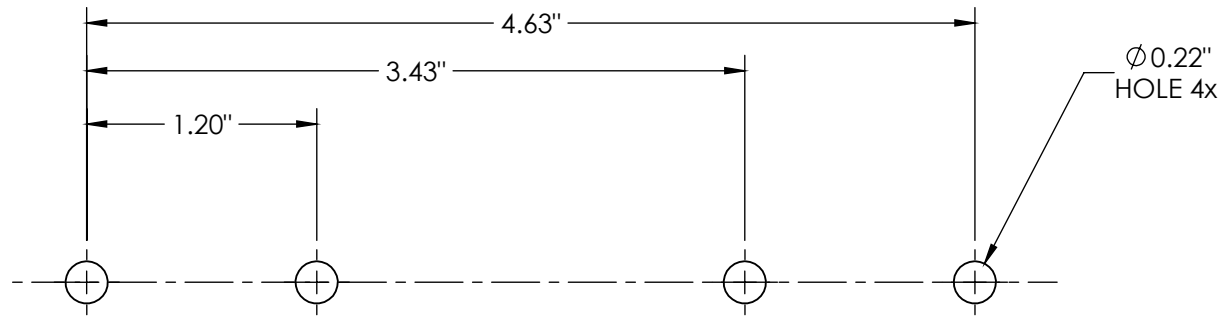

DOUBLE MOUNT DECK/ GRILLE TEMPLATE

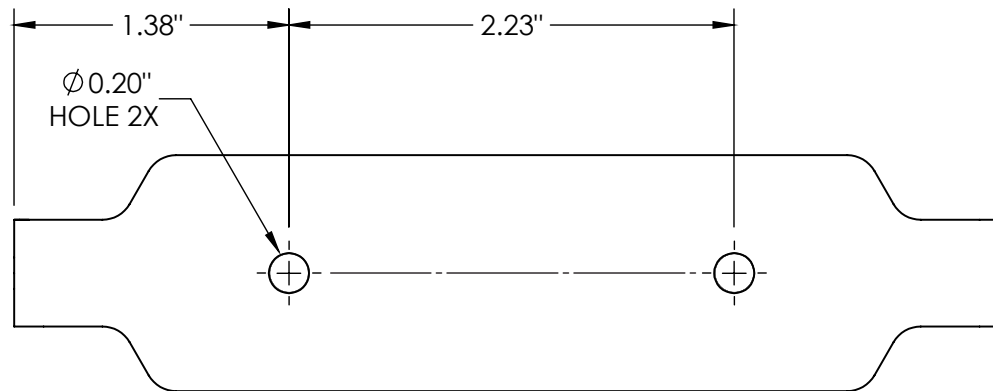

DECK/ GRILLE TEMPLATE