

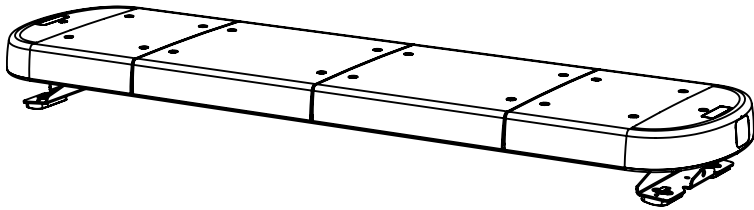

#EMG2000 MAGNUM LED Lightbar 10-30V



IMPORTANT NOTICE TO INSTALLER: Make sure to read and understand all instructions and warnings before proceeding with the installation of this product. Ensure that the manual and any warning cards are delivered to the end user of this equipment. Proper installation of the lightbar requires the installer to have a thorough knowledge of automotive electronics, systems, and procedures. Lightbars provide an essential function of an effective visual warning system. The use of the lightbar does not insure that all drivers can or will abide by or react to an emergency warning signal, especially at high rates of speeds or long distances. The operator of the vehicle must never take the right of way for granted and it is the operator's responsibility to proceed safely. The effectiveness of the lightbar is highly dependant on the correct mounting and wiring. The installer must read and follow the manufacturer's installation instructions and warnings in the manual. The vehicle operator should verify daily that the lightbar is securely fastened to the vehicle and properly functioning before operating vehicle. The lightbar is intended for use by authorized personnel only. It is the user's responsibility to ensure they understand and operate the emergency warning devices in compliance with the applicable city, state and federal laws and regulations. SoundOff Signal assumes no liability for any loss resulting from the use of this warning device.

Components/Contents

Standard Equipment:

- 1 - EMG2000 MAGNUM™ LED Lightbar built to your specifications

Other Parts that may be included depending on your configuration:

- 1 - Vehicle Specific Hook Kit w/ Hardware*
- 2 - Fixed Height Mounting Brackets w/ Hardware or
- 1 - Flat Mount Hardware Kit or
- 2 - Headache Brackets w/ Hardware

*Kits will vary with each lightbar depending on vehicle specified on order form.

Unpack Lightbar

1. Remove the lightbar from box and packaging.
2. Save packaging for later shipping.
3. Check components/contents.
4. Please reference these instructions for proper wiring and installation.

Tools Required for Installation

- 1/2" Socket with ratchet or 1/2" box end
- Phillips Head Screwdriver
- Drill bit #30



1.800.338.7337 / www.soundoffsignal.com

TABLE OF CONTENTS

PAGE	CONTENT
1	COMPONENTS/ CONTENTS
2	MODULE SPECIFICATIONS
3	TECHNICAL/ POWER SPECIFICATIONS
4-7	FIXED HEIGHT BRACKETS MOUNTING
8	ELECTRICAL INSTALLATION
9	ELECTRICAL INSTALLATION (CONTINUED)
10	MAGNUM LIGHTBAR SPEAKER
11	CONTROL HARNESS
12	FLASH PATTERNS AND CONNECTOR INSTRUCTIONS
13	LIGHT MODULE WIRE HARNESS LOCATIONS
14	MAGNUM TROUBLESHOOTING
15	REPLACEMENT PARTS
16	WARRANTY AND RETURN GOODS PROCEDURE

Important Information:

- Warning devices are strictly regulated and governed by Federal, State and Municipal ordinances. These devices shall be used ONLY on approved vehicles. It is the sole responsibility of the user of these devices to ensure compliance.
- DO NOT install this product or route any wires in the Air Bag Deployment Zone. Refer to your vehicle Owner's Manual for the location of any air bag deployment zones.
- DO NOT connect this device to a strobe power supply. This product is self-contained and does not require an external power supply.



NOTICE:

Installers and users must comply with all applicable federal, state and local laws regarding use and installation of warning devices. *Improper use or installation may void warranty coverage. To review our Limited Warranty Statement & Return Policy for this or any SoundOff Signal product, visit our website at www.soundoffsignal.com/sales-support. If you have questions regarding this product, contact **Technical Services**, Monday - Friday, 8 a.m. to 5 p.m. or after hours 5 p.m. to 8 p.m. EST at 1.800.338.7337 (press #4 to skip the automated message). Questions or comments that do not require immediate attention may be emailed to techservices@soundoffsignal.com.*

SUPERIOR CUSTOMER RELATIONSHIPS. SMARTLY DESIGNED LIGHTING & ELECTRONIC SOLUTIONS.

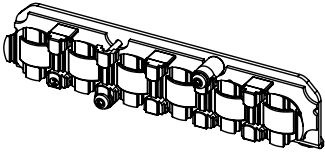
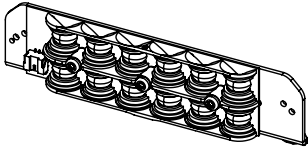
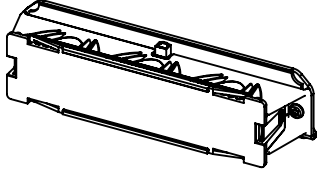
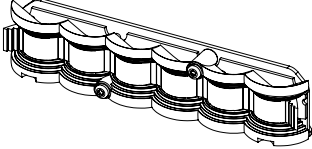
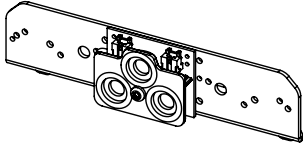
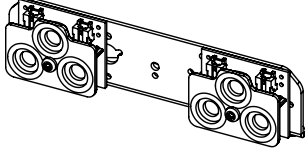
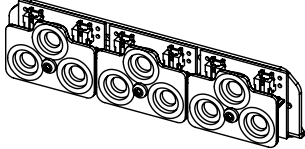
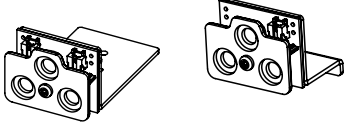

#EMG2000 MAGNUM LED Lightbar 10-30V

	<p>Fusion Boost 6 LED Inboard Module INPUT VOLTAGE RANGE: 10-30Vdc CURRENT DRAW: 0.35 Amps @ 12.8 Vdc (Flashing) 0.70 Amps @ 12.8 Vdc (Steady On) WATTAGE: 4.5W (Flashing)</p>
	<p>Fusion 12 LED Corner Module INPUT VOLTAGE RANGE: 10-30Vdc CURRENT DRAW: 0.8 Amps @ 12.8 Vdc (Flashing) 1.6 Amps @ 12.8 Vdc (Steady On) WATTAGE: 10.2W (Flashing)</p>
	<p>Turbo Optic 3 LED Inboard Module INPUT VOLTAGE RANGE: 10-30Vdc CURRENT DRAW: 0.18 Amps @ 12.8 Vdc (Flashing) 0.35 Amps @ 12.8 Vdc (Steady On) WATTAGE: 2.3W (Flashing)</p>
	<p>Fusion 6 LED Corner Module INPUT VOLTAGE RANGE: 10-30Vdc CURRENT DRAW: 0.35 Amps @ 12.8 Vdc (Flashing) 0.70 Amps @ 12.8 Vdc (Steady On) WATTAGE: 4.5W (Flashing)</p>
	<p>Takedown 3 LED Module INPUT VOLTAGE RANGE: 10-30Vdc CURRENT DRAW: 0.18 Amps @ 12.8 Vdc (Flashing) 0.35 Amps @ 12.8 Vdc (Steady On) WATTAGE: 2.3W LIGHT OUTPUT: 240lm</p>
	<p>Takedown 6 LED Module INPUT VOLTAGE RANGE: 10-30Vdc CURRENT DRAW: 0.35 Amps @ 12.8 Vdc (Flashing) 0.70 Amps @ 12.8 Vdc (Steady On) WATTAGE: 4.5W LIGHT OUTPUT: 480 lm</p>
	<p>Takedown 9 LED Module INPUT VOLTAGE RANGE: 10-30Vdc CURRENT DRAW: 0.53 Amps @ 12.8 Vdc (Flashing) 1.05 Amps @ 12.8 Vdc (Steady On) WATTAGE: 6.8W LIGHT OUTPUT: 720 lm</p>
	<p>Inboard/Alley 3 LED Module INPUT VOLTAGE RANGE: 10-30Vdc CURRENT DRAW: 0.18 Amps @ 12.8 Vdc (Flashing) 0.35 Amps @ 12.8 Vdc (Steady On) WATTAGE: 2.3W LIGHT OUTPUT: 240 lm</p>

FLASHING = AVERAGE

STEADY ON (100%) = PEAK

25.6Vdc = Divide currents by 2. Wattage remains the same.



#EMG2000 MAGNUM LED Lightbar 10-30V

TOP VIEW WITH COVERS ON

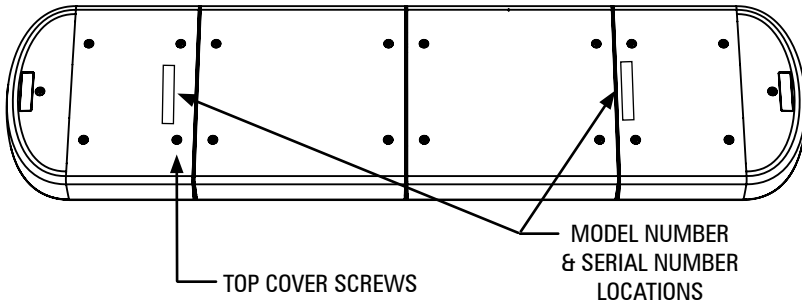

TOP VIEW WITH COVERS OFF

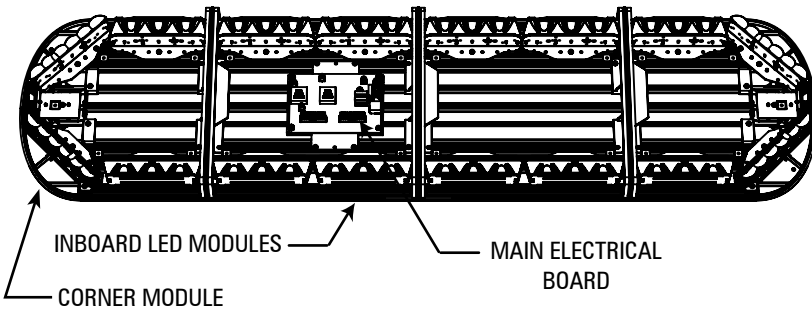

BOTTOM VIEW

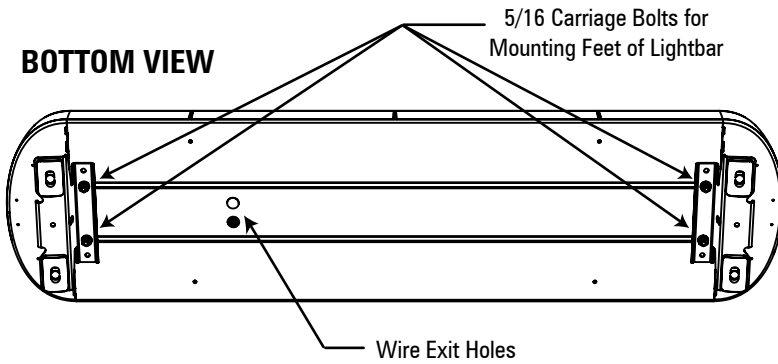

TECHNICAL SPECIFICATIONS

Material:	Aluminum Base, Nylon base end caps, polycarbonate outer lenses, acrylic inner lenses .		
Roof Attachments:	1/4" bolt Stainless A2		
Operating Temperature:	-40° to +65° C		
LENGTH	# OF INBOARDS WITH SPEAKER	# OF INBOARDS WITHOUT SPEAKER	DIMENSIONS
23"	2	-	WITHOUT SPEAKER: 12.4"D x 2.3"H inboard
35.5"	4	-	
41.8"	5	4	
48"	6	4	WITH SPEAKER: 12.4"D x 2.8"H inboard
54.3"	7	6	
60.5"	8	-	
73"	10	-	

POWER SPECIFICATIONS

Input Voltage Range:	10 -30 Vdc	
Light Bar Component	Current Draw (Average = Flashing)	Power Consumption (Watts)
Standby Current	.022 Amps	.28 Watts
Reverse Polarity	Fuse Protected	
Load Dump	Protected	
Wiring	Power Cable 15ft 10 AWG Wires, (+) Red, (-) Black Data Cable 15ft RJ-45 Type	

Optional 16ft. 18AWG 2 Conductor Speaker Harness



#EMG2000 MAGNUM LED Lightbar 10-30V

Low Profile Mounting Foot

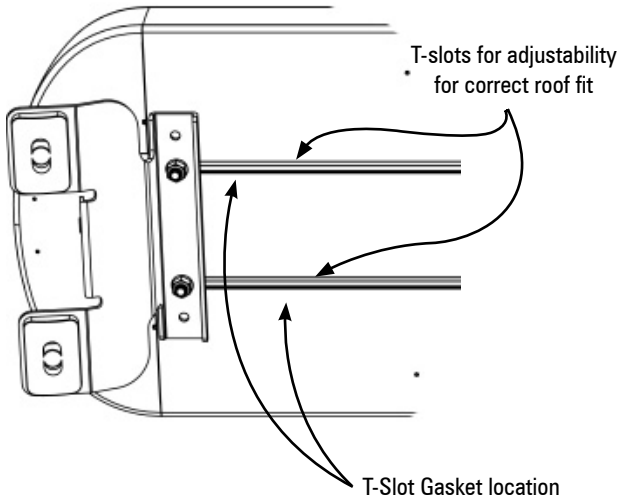
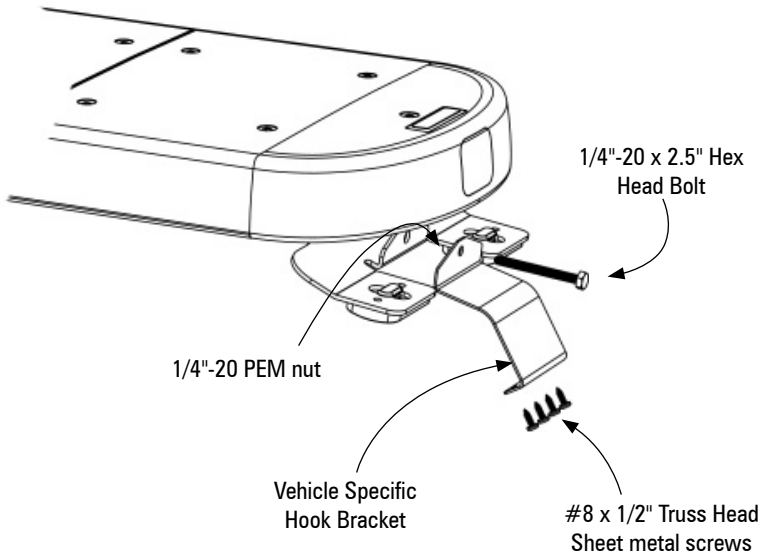

FIXED HEIGHT BRACKETS AND HOOK MOUNTING

1. Slide 5/16 carriage bolts into extrusion t-slots. Place mounting foot onto slots and tighten foot with washer and nut, ensuring the use of either a lock washer or lock nut
2. Temporarily place lightbar in its correct position on the roof of the vehicle. The bar should be positioned about the center of the vehicle B pillar. Determine the appropriate position of the mounting feet brackets on the lightbar to the vehicle roof and reposition mounting feet as needed.
3. Install supplied vehicle specific hook brackets using supplied 1/4"-20 x 2.5 Hex Head bolts onto the bar mounting foot as shown. Nut is attached to mounting foot to prevent turning and improve ease of installation. If bolt ends come in contact with the mounting feet, reposition the mounting feet.
4. Using the vehicle specific hook brackets as a template, drill 4 pilot holes using a #30 (.128 dia.) drill bit on each side of the vehicle.
5. Secure each vehicle specific hook brackets by using the 8 supplied #8 x 1/2" Truss Head Sheetmetal screws, 4 per side.
6. Tighten each vehicle specific hook bracket to mounting foot by turning the 1/4" -20 x 2.5 Hex head bolt clockwise until bar is snug and no side to side or fore to aft movement occurs. Due to different vehicle construction and mounting locations, the torque levels for connecting hooks to the lightbar foot may be different based on the vehicle. Minimum requirement for torque should be 10 IN/LB, with a maximum level of 45 IN/LB. Deflection of the lightbar and/or the roof of the vehicle may occur when torqueing the bolts connecting the hook to the lightbar foot. When installing the bolts connecting the hook to the lightbar foot, monitor both the lightbar and roof of the vehicle. Any deflection should be kept at a minimum to avoid damage to the lightbar or vehicle. Tighten to ensure there is no movement of the lightbar or foot by ensuring there is no movement either side to side, or front to rear after the torque has been done. The lightbar must be securely mounted to the vehicle for safe operation. As always, it is recommended to check the integrity of mounted lightbars on a daily basis to ensure secure attachment to the vehicle for continued safe operation.
7. Route cables into vehicle. Use supplied rubber grommet in roof for sealing/ protection of wires. It is recommended that silicone be placed around grommet to ensure roof sealing.

WARNING

Route wires only in locations that are not subjected to potential wear. Make sure to avoid routing wires in the deployment area of your air bag. Refer to your vehicle's owner's manual for airbag deployment zone.



#EMG2000 MAGNUM LED Lightbar 10-30V

Extra Low & Permanent Mounting Foot

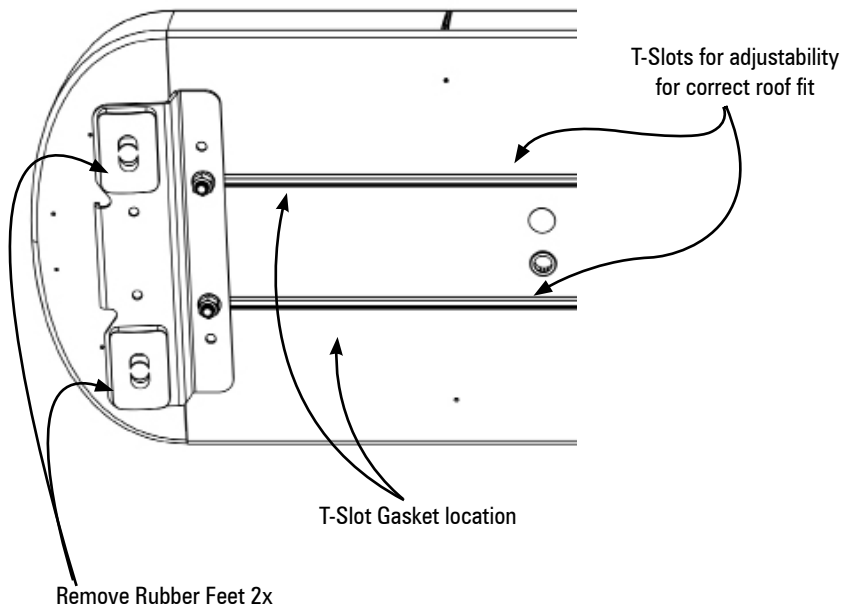
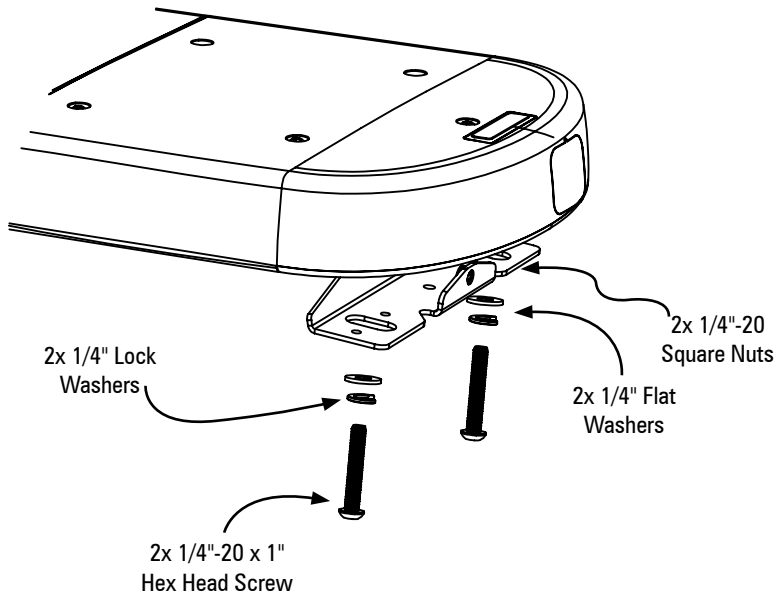

FIXED HEIGHT BRACKETS PERMANENT MOUNTING

1. Locate the permanent hardware kit that is included.
2. Slide 5/16 carriage bolts into extrusion t-slots. Place mounting foot onto slots and tighten foot with washer and nut, ensuring the use of either a lock washer or lock nut.
3. Temporarily place lightbar in its correct position on the roof of the vehicle. The bar should be positioned about the center of the vehicle B pillar. Determine the appropriate position of the mounting feet brackets on the lightbar to the vehicle roof and reposition mounting feet as needed.
4. Remove the rubber feet.
5. Measure and/or mark the 2 holes in roof to match mounting feet locations. See warning messages below. Drill holes for 1/4" bolts (F drill).
6. Install hardware as shown in image to the left.
7. Route cables into vehicle. Use supplied rubber grommet in roof for sealing/ protection of wires. It is recommended that silicone be placed around grommet to ensure roof sealing.

⚠ WARNING

Care must be taken when drilling through the roof of the vehicle not to drill into any existing wiring and not to drill through the headliner or support members of the vehicle. Check both sides of the mounting service prior to drilling. De-burr any holes and remove any metal shards or remnants. Install grommets into all wire passage holes.

⚠ WARNING

Route wires only in locations that are not subjected to potential wear. Make sure to avoid routing wires in the deployment area of your air bag. Refer to your vehicle's owner's manual for airbag deployment zone.



#EMG2000 MAGNUM LED Lightbar 10-30V

Premium Fixed Height Foot

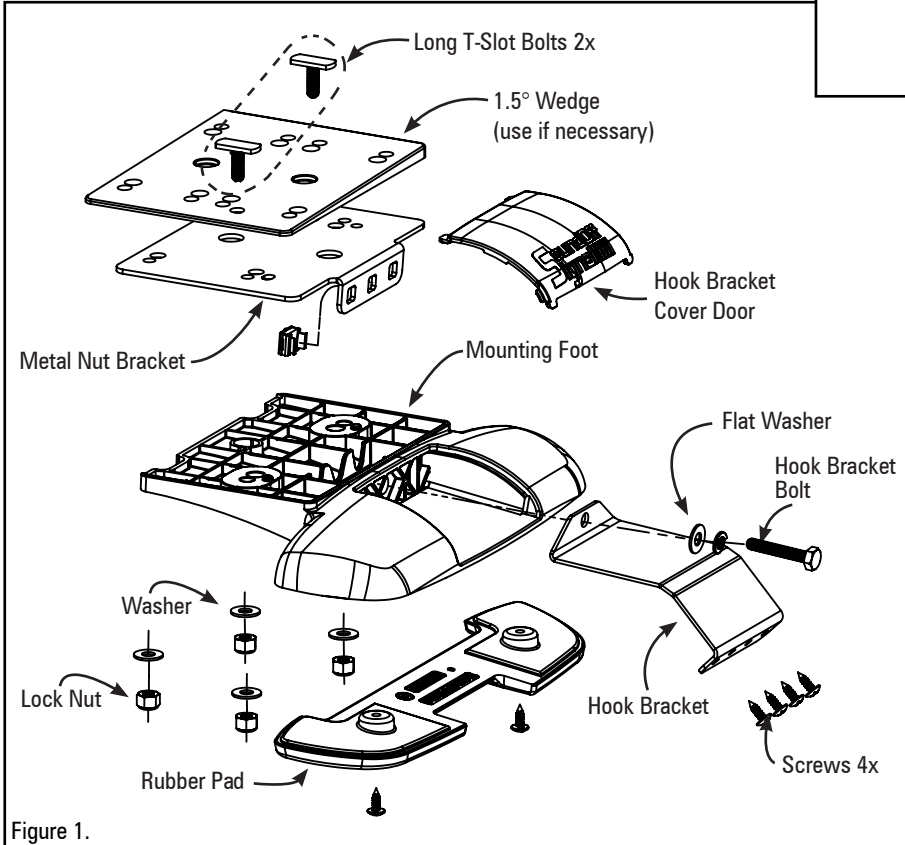
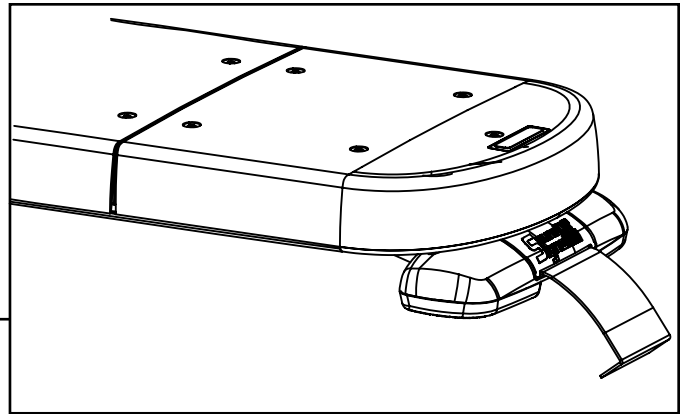

Figure 1.

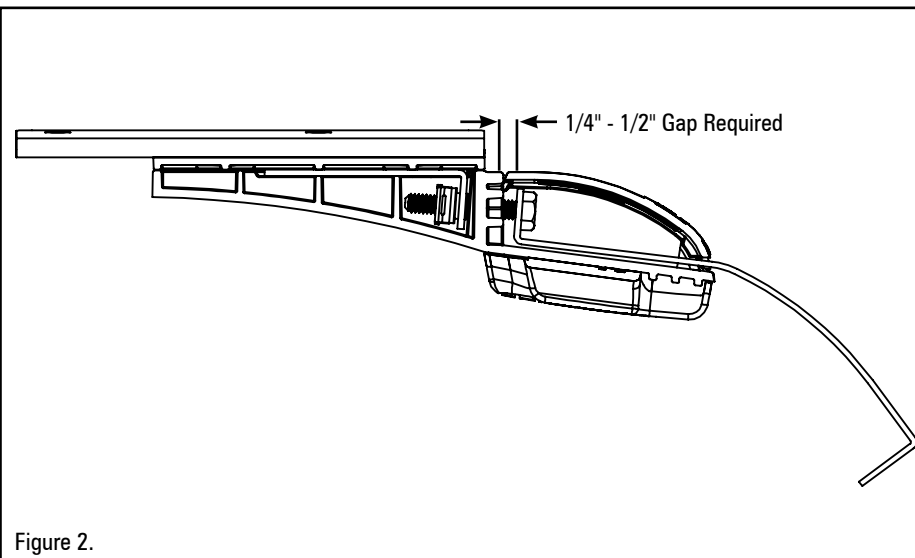

Figure 2.

FIXED HEIGHT BRACKETS AND HOOK MOUNTING (NON-PURSUIT)

1. Keeping the lightbar level with the road, attach Mounting Feet to the roof of the vehicle using the 2 supplied T-Slot bolts. If the lightbar needs to be leveled, a 1.5° wedge has been provided.
2. Place lightbar centered on the roof, and hold brackets up to the lightbar. A 1/4" to 1/2" gap should be between the hook bracket and front wall of the mounting foot prior to putting any tension on the hook bracket bolt (See Figure 3). Adjust the mounting foot position to accommodate for this gap.
3. Tighten 2 lock nuts to secure mounting foot to lightbar with max torque between 80-90in/lbs. **DO NOT OVERTIGHTEN!**
4. Using holes in the hook bracket as a template, drill 4 holes in the roof using the appropriate size drill. Secure hook bracket to roof with 4 screws on each side.
5. Tighten the 2 hook bracket bolts. Due to different vehicle construction and mounting locations, the torque levels for connecting hooks to the lightbar foot may be different based on the vehicle. Minimum requirement for torque should be 10 IN/LB, with a maximum level of 45 IN/LB. Deflection of the lightbar and/or the roof of the vehicle may occur when torquing the bolts connecting the hook to the lightbar foot. When installing the bolts connecting the hook to the lightbar foot, monitor both the lightbar and roof of the vehicle. Any deflection should be kept at a minimum to avoid damage to the lightbar or vehicle. Tighten to ensure there is no movement of the lightbar or foot by ensuring there is no movement either side to side, or front to rear after the torque has been done. The lightbar must be securely mounted to the vehicle for safe operation. As always, it is recommended to check the integrity of mounted lightbars on a daily basis to ensure secure attachment to the vehicle for continued safe operation.
6. Install the cover door over the hook bracket bolt to finish the assembly. Place tab of one side into place and then push the second tab into place with a flat-head screw driver.

⚠ WARNING

Route wires only in locations that are not subjected to potential wear. Make sure to avoid routing wires in the deployment area of your air bag. Refer to your vehicle's owner's manual for airbag deployment zone.



#EMG2000 MAGNUM LED Lightbar 10-30V

Premium Fixed Height Foot

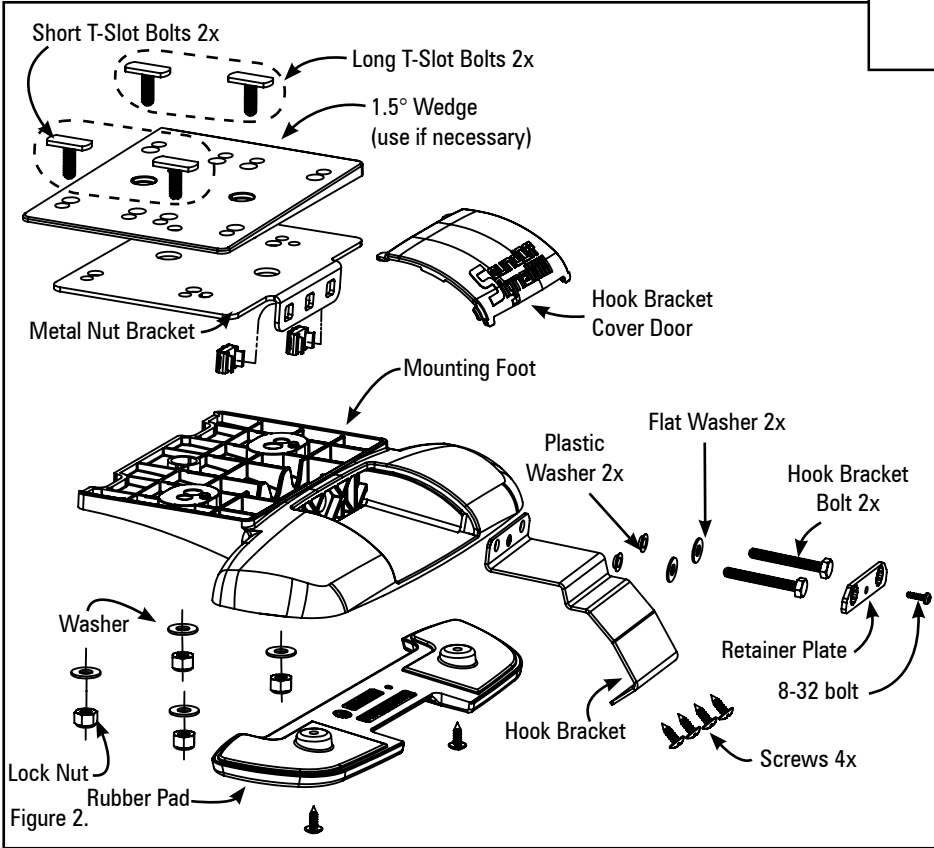
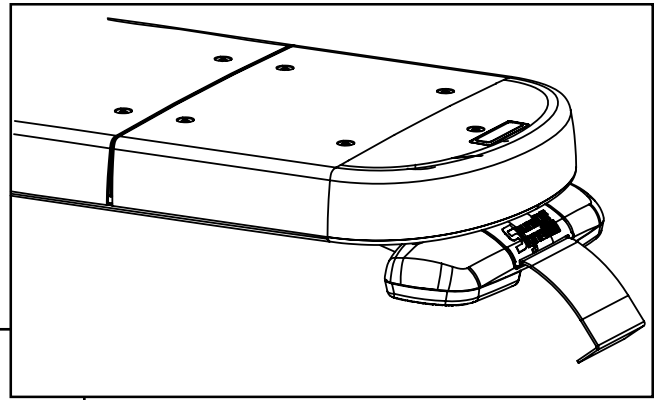

FIXED HEIGHT BRACKETS AND HOOK MOUNTING (PURSUIT)

1. Attach the supplied screws to the mounting foot to secure the rubber pad as shown in Figure 3. Be sure the torque does not exceed 10 IN-LB.
2. Insert the 2 plastic washers inside holes of the provided hook brackets.
3. Keeping the lightbar level to the road, attach mounting feet to the roof of the vehicle using the 4 supplied T-Slot bolts.
4. Place lightbar centered on the roof, and hold brackets up to the lightbar. A 1/4" to 1/2" gap should be between the hook bracket and front wall of the mounting foot prior to putting any tension on the hook bracket bolt (See Figure 4). Adjust the mounting foot position to accommodate for this gap.
5. Tighten 4 lock nuts to secure mounting foot to lightbar with max torque between 80-90in/lbs. **DO NOT OVERTIGHTEN!**
6. Using the holes in the hook bracket as a template, drill 4 holes in the roof using the appropriate size drill. Secure hook bracket to roof with 4 screws on each side.
7. Tighten the 4 hook bracket bolts. Due to different vehicle construction and mounting locations, the torque levels for connecting hooks to the lightbar foot may be different based on the vehicle. Minimum requirement for torque should be 10 IN/LB, with a maximum level of 45 IN/LB. Deflection of the lightbar and/or the roof of the vehicle may occur when torquing the bolts connecting the hook to the lightbar foot. When installing the bolts connecting the hook to the lightbar foot, monitor both the lightbar and roof of the vehicle. Any deflection should be kept at a minimum to avoid damage to the lightbar or vehicle. Tighten to ensure there is no movement of the lightbar or foot by ensuring there is no movement either side to side, or front to rear after the torque has been done. The lightbar must be securely mounted to the vehicle for safe operation. As always, it is recommended to check the integrity of mounted lightbars on a daily basis to ensure secure attachment to the vehicle for continued safe operation.
8. Insert the retainer plates over the 2 bolts on each of the hook kit brackets. Screw in the retainer plate to the hook kit bracket using the 8-32 bolts.
9. Install the cover door over the hook bracket bolt to finish the assembly. Place tab of one side into place and then push the second tab into place with a flat-head screw driver.

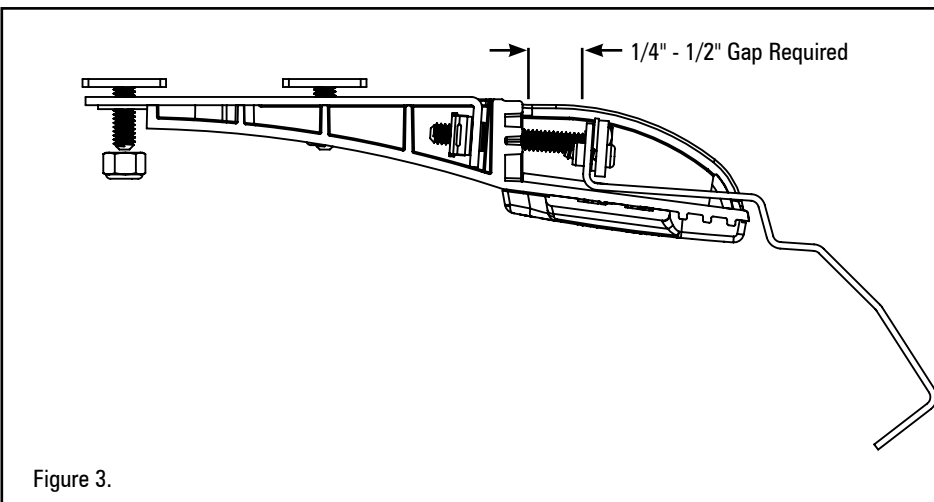

Figure 3.

⚠ WARNING

Route wires only in locations that are not subjected to potential wear. Make sure to avoid routing wires in the deployment area of your air bag. Refer to your vehicle's owner's manual for airbag deployment zone.



#EMG2000 MAGNUM LED Lightbar 10-30V

ELECTRICAL INSTALLATION

Featured Highlights:

Mode Select: The MAGNUM™ Lightbar is equipped with 2 selectable pattern configuration modes via the Mode Select Input. Default is Mode 1 where the input is floating, Mode 2 is in use when the input is activated. This feature allows 2 complete sets of patterns to be programmed into the Lightbar's non-volatile memory. Once programming configuration is complete, the Mode can be changed "on-the-fly" by an activation switch.

Cruise Mode: Allows the user to program any Light Head Group(s) to "Glow" when this feature is activated.

Directional Arrow Built-in: If the lightbar was purchased with a directional arrow, the directional controller is built-in w/4 arrow patterns for each direction and 9 warning patterns for warning functions.

Auxiliary Output: The lightbar is equipped with one 3.5A auxiliary output. Connect +10-30Vdc or an external flasher output to Aux_In using a .250" female spade terminal or apply power to Breakout Box Light Green Wire, pin 5 for activation. Connect ground and power of Auxiliary Light to GND and AUX_OUT using .250" female spades.

WARNING

ALL CUSTOMER SUPPLIED POWER WIRES CONNECTING TO THE POSITIVE (+) OR NEGATIVE (-) BATTERY TERMINAL OR LOCAL CHASSIS GROUND (-) MUST BE SIZED TO SUPPLY AT LEAST 125% OF THE MAXIMUM CURRENT AND PROPERLY FUSED AT THE POWER SOURCE WITH APPROPRIATELY RATED FUSE.

Power Cable:

1. Route lightbar power cables as close to vehicles power source (battery) as possible.
2. Install a 40Amp Fuse (customer supplied) to the end of the RED wire of the Lightbar Power Cable.
 - a. Remove the fuse before connecting any wires to the battery.
 - b. DO NOT USE CIRCUIT BREAKER OR FUSIBLE LINK.
3. Connect the other end of the Fuse to the Positive (+) terminal of the battery.
 - a. DO NOT use any more than 2ft of wire between the battery terminal and the fuse. Ensure the wire is protected and secured from being cut into: this non-fused wire
4. Connect the BLACK wire to the factory chassis ground right next to the battery.

Control/Data Cable:

1. Route Lightbar Control Cable to the location where all controlling equipment will be, i.e. switch box, center console area.
2. Locate the Breakout Box in the same area to connect jumpers from the switching equipment to the breakout box.

NOTE: Power is supplied to Breakout Box through data cable, no additional power connections necessary.

Speaker Wire:

1. Connect wires to amplifier, if applicable.

Initial Power up Test:

1. Insert 40 Amp Fuse (not included) into Fuse Holder (as stated above).
2. Plug data jack into Data 1 connector of the Breakout Box.
3. Observe the GREEN Data Link indicator LED on the Breakout Box; the LED will turn steady ON about 15 seconds after main power is connected.
4. When GREEN LED is steady ON (see below), the lightbar is ready to be configured.

Low Power (Standby) Mode

If there is no output to the breakout box for 15 seconds, the lightbar will go into a "standby" mode. The standby mode is a low power mode that is used to extend the life of your battery. The green light will turn off when the lightbar enters standby mode. The red light will flash every five seconds showing that it has power. The lightbar will awaken from the standby mode if any input is activated on the breakout box.

NOTE: In standby mode, each switch in the down position will contribute to another 0.03A of standby current.



#EMG2000 MAGNUM LED Lightbar 10-30V

ELECTRICAL INSTALLATION (CONTINUED)

Pattern Selection

- a. First review the Pattern Table (included on pg. 10) before attempting pattern selection to familiarize yourself with patterns available for the different Functions.
 - i. Depending on the Lightbar configuration purchased, the Arrow Pattern Table may or may not be applicable.
- b. Select the input Function(s) on breakout box (pg. 9).
 - i. To change patterns on more than one input function, simply connect desired input functions together. Before doing this, make sure all the inputs are using the same pattern table and are on the same pattern to make pattern identification easier.
- c. Momentarily apply +Vdc to the pattern select input on breakout box to advance to the next pattern.
 - i. Once the last pattern is reached, the next pattern advance will cycle back to pattern #1.
- d. Once the desired pattern is reached, simply disconnect the Input Function(s) and proceed to the next Input Function(s) to be configured.
 - i. The pattern is saved in non-volatile memory every time it is advanced.

Mode Configuration:

- a. Mode 1 (Default): the Mode Select Input will be floating (no-connection)
 - i. Continue on to Pattern Selection instructions (pg. 10) to set the patterns for this Mode.
- b. Mode 2: apply +Vdc to activate Mode 2. This will need to be activated to configure the lightbar in Mode 2.
 - i. Continue on to Pattern Selection instructions (pg. 10) to set the patterns for this Mode.
 - ii. Once patterns have been setup, connect Mode Select Input to switching system.
 - iii. When the Mode Select Input is activated, the Mode 2 Patterns will flash.

Cruise Mode Configuration:

- a. Apply +Vdc to activate Cruise Mode for configuration setup.
- b. Determine what Input Function(s) are desired to useCruise Mode.
- c. Apply +Vdc to the Input Function(s) desired.
 - i. NOTE: Lights will flash preset flash pattern
- d. With both the Cruise Mode Input and the Inputs functions activated, momentarily apply +Vdc to the pattern select wire to toggle the Cruise Mode to ON (default is OFF).
- e. Observe the OFF sequence of the flash pattern is ON dim.
- f. Disconnect the Input Function wire(s) (while leaving cruise mode input activate) and observe the lightbar is NOT flashing, but the output function(s) recently set are glowing steady.

WARNING

Route wires only in locations that are not subjected to potential wear. Make sure to avoid routing wires in the deployment area of your air bag. Refer to your vehicle's owner's manual for airbag deployment zone.

IMPORTANT

WHEN PASSING CABLES THROUGH FIREWALL OR OTHER SHEETMETAL, INSERT GROMMET TO PROTECT THE CABLE!



#EMG2000 MAGNUM LED Lightbar 10-30V

MAGNUM LIGHTBAR SPEAKER (CONFIGURED OPTION)

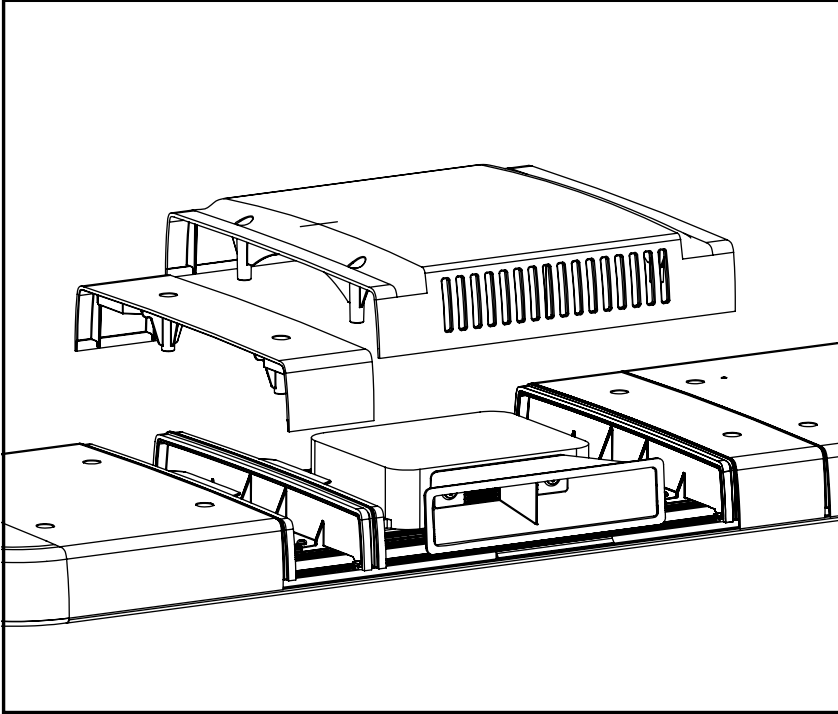

TECHNICAL SPECIFICATIONS FOR SPEAKER

Power Rating	100 Watts RMS
Impedance	8-11 Ohms Nominal
Frequency Response	200-5000 Hz +/-10dB Nominal

Introduction:

The optional siren loudspeaker is used for high powered transmission of electronic siren and voice communications in vehicular applications.

Qualifications:

To properly install a siren, you must have a good understanding of automotive systems, electronics, and procedures.

The siren/speaker system is intended for use by authorized personnel only. The user's responsibility to ensure they understand and operate the emergency warning devices in compliance with all applicable city, state, and federal laws and regulations and have a thorough knowledge of state and federal UNIFORM TRAFFIC CODES.

SoundOff Signal assumes no liability for any loss resulting in the use of this warning device.

During Installation:

Do not route the speaker wires where they may interfere with the operations or deployment of the air bag or its sensors. Equipment mounted near the air bag deployment area will damage or reduce the effectiveness of the air bag. The user/installer assumes full responsibility to determine proper mounting location, based on providing safety for passengers inside the vehicle.

After Installation:

1. Test the siren and light system to ensure that everything is operating properly.
2. Test all vehicle functions to ensure that installation has not affected vehicle operation or changed vehicle safety function.
3. Store these instructions in a safe place and refer to them when performing maintenance and/or reinstallation of product.



WARNING

- Sirens produce loud sounds that may damage hearing:
- Roll up windows.
 - Wear hearing protection.
 - Use only for emergency response.
 - Avoid exposure to siren sound outside of vehicle.



#EMG2000 MAGNUM LED Lightbar 10-30V

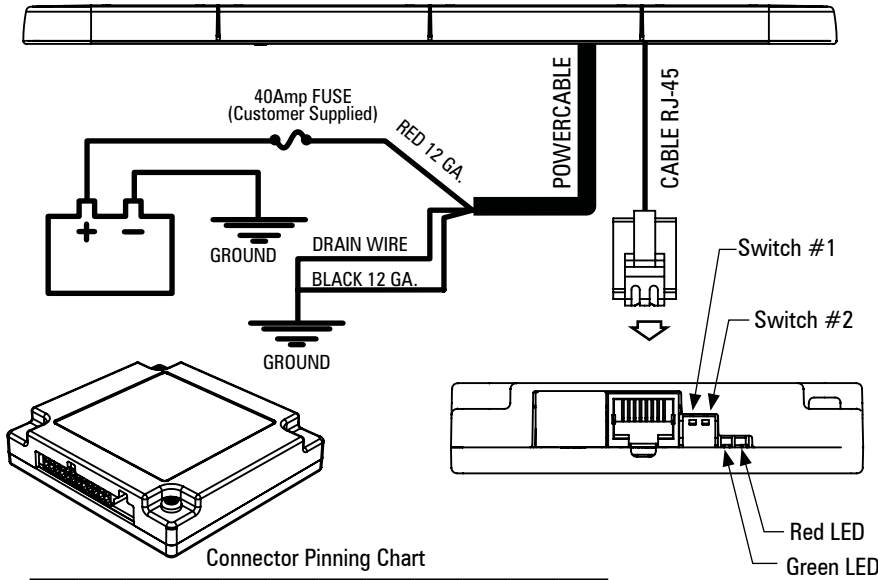

BREAKOUT BOX

RED LIGHT

- No Input Flashes every 5 seconds
- Input Activated Steady On
- Added Input Brief Flash

GREEN LIGHT

- Command Rec'd Steady On Has good connection (See Below)

- Up = Active High
- Down = Active Low

- When the switch is in the up position inputs connected to that switch are active high. To activate an active high input, apply +Vdc.
- When the switch is in the down position Inputs connected to that switch are active low. To activate the active low, apply ground (negative).

Connector Pinning Chart

24	23	22	21	20	19	18	17	16	15	14	13
12	11	10	9	8	7	6	5	4	3	2	1

- Controlled by Active Low Switch #2
- Controlled by Active Low Switch #1

Note - Reference Switch table for explanation of what inputs are affected by Active Low Switches.

Wire Color (Major Color/ Stripe)	Pin#	Standard Functions (4 Wire Arrow Control)	Discrete Functions (8 Wire Arrow Control)
Light Green/ White	24	Left Turn Signal*	Discrete Output #4*
Red/ Black	23	Right Turn Signal*	Discrete Output #3*
Orange/ White	22	Rear Inboard 3	Discrete Output #2*
Yellow/ White	21	Rear Inboard 2	Discrete Output #1* (L)*
Brown	20	Front Take down	Front Take down
Red/ White	19	Alley Flash	Alley Flash
Pink	18	Alley Driver	Alley Driver
Red	17	Alley Passenger	Alley Passenger
Orange	16	Front Inboard 3	Front Inboard 3
Yellow	15	Front Inboard 2	Front Inboard 2
Green	14	Front Inboard 1	Front Inboard 1
Blue	13	Front Corners	Front Corners
Pink/ White	12	Arrow, Left*	Discrete Output #8 (R)*
Purple/ White	11	Arrow, Center*	Discrete Output #7*
Gray/ White	10	Arrow, Right*	Discrete Output #6*
Black/ White	9	Arrow, Warning	Discrete Output #5*
White	8	Pattern Select*	Pattern Select*
Purple	7	Low Power	Low Power
Brown/ White	6	Front Take down Flash	Front Take down Flash
Light Green	5	Auxiliary*	Auxiliary*
Black	4	Cruise Lights*	Cruise Lights*
Gray	3	Mode Select*	Mode Select*
Green/ White	2	Rear Inboard 1	Rear Inboard 1
Blue/ White	1	Rear Corners	Rear Corners

Functional Inputs
Functional Inputs connect to your control head or switching unit. Applying +Vdc to any functional Input will activate it's function (default-active high).

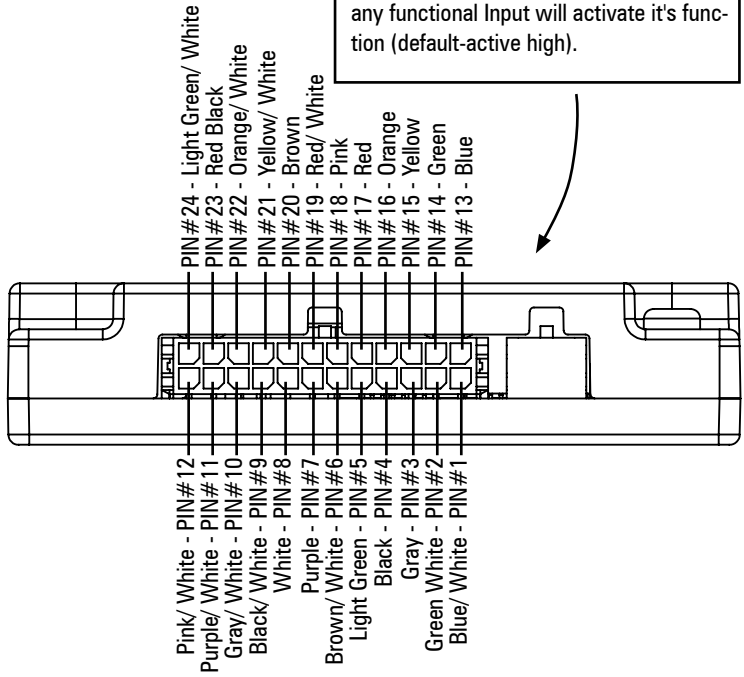



#EMG2000 MAGNUM LED Lightbar 10-30V

FLASH PATTERNS AND CONNECTOR INSTRUCTIONS BREAKOUT BOX

LED Module Flash Patterns				
#	Pattern Name	Sequence	fpm*	fps**
1	Quint	Alternating	70	1.18
2	Warp	Alternating	350	5.88
3	Inter-Cycle Flash	Alternating	-	-
4	Quad Flash	Alternating	80	1.35
5	RoadRunner™	Alternating	115	1.92
6	RoadRunner™	Simultaneous	115	1.92
7	Slow Runner	Alternating	70	1.16
8	Slow Runner	Simultaneous	70	1.16
9	Q-Switch™	Variable	-	-
10	Single, Steady Burn	Steady Burn	115	1.92
11	Quad, Steady Burn	Steady Burn	80	1.35
12	Warp, Steady Burn	Steady Burn	350	5.88
13	Nothing, Steady Burn	Steady Burn	-	-
14	E-Pattern Single Flash	Alternating	230	3.85
15	E-Pattern Double Flash	Alternating	128	2.13
16	E-Pattern Single Flash	Simultaneous	230	3.85
17	E-Pattern Double Flash	Simultaneous	155	2.6
18	Warp 1,2,3,4	Variable	-	-
19	Warp 2,3,1	Variable	-	-
20	Warp 3,2,1	Variable	-	-
21	Steady Burn	Steady Burn	-	-

Directional Bar Warning Function Patterns				
1	PowerPulse™ Alternating	Center Out	180	3.00
2	PowerPulse™ Alternating	Left/ Right	180	3.00
3	Quad Alternating	Center Out	80	1.35
4	Warp Alternating	Adjacent	3.50	5.88
5		2X Individual Sweep	-	-
6	Hyper Scan	Pulsing + Sweep	-	-
7	Super Scan	Dual Rate Pulse/ Alt	-	-
8	Power Flash	Dual Rate Alt/ Pulse	-	-
9	Thunder and Lighting	Random	-	-
10	Steady Burn	Steady Burn	-	-

Split Arrow Bars Also Have The Following Multi-color Patterns				
10	RoadRunner™	Alternating	115	1.92
11	Warp	Adjacent	350	5.88
12	Warp	Adjacent	350	5.88
13	Inter-Cycle Flash	Adjacent	-	-
14	Inter-Cycle Flash	Alternating	-	-
15	Inter-Cycle Flash	Alternating	-	-
16	Inter-Cycle Flash	Alternating	-	-
17	Inter-Cycle Flash	Alternating	-	-
18	Steady Burn	Steady Burn	-	-

*fpm=Flashes per Minute
**fps=Flashes per Second

Directional Bar Directional Function Patterns For Left, Center Out, & Right Sequences		
1	Solid Arrow Plus, Slow	Grow / Decay
2	Solid Arrow, Slow	Solid
3	Individual Arrow, Fast	Individual
4	Chaser Arrow, Fast	2x Individual
4	Chaser Arrow, Fast	2X Individual

LED Take down & Alley Flash Pattern				
1	RoadRunner™	Alternating	115	1.92
2	PowerPulse™	Alternating	180	3.00
3	Q-Switch™	Variable	-	-
4	ETM™	Simultaneous	214	3.57
5	Steady Burn	Steady Burn	-	-

LIGHTBAR CONTROLLER CONNECTOR INSTRUCTIONS

Input Group Control	Light Output Groups
Front Inboard 1	Red, Yellow
Front Inboard 2	Green
Front Inboard3	Blue
Rear Inboard 1	Red, Yellow
Rear Inboard 2	Green
Rear Inboard3	Blue
Take Down	White, Orange

* Rear inboards have RED and BLUE wires
* Front inboards have GREEN wires

BREAKOUT BOX HOOKUP:

Make sure the 24-pin connector and the RJ-45 connector are snapped in securely.

Follow the label for the wire color to connect to a 10-30Vdc source, which turns on that given light or lights.

Make sure your wire connections are secured and isolated from any other wire.

SWITCH SETTINGS						PURPOSE
SW1	SW2	SW3	SW4	SW5	SW6	8 WIRE ARROW CONTROL
OFF	OFF	OFF				NO ARROW (DEFAULT)
OFF	OFF	ON				N/A
OFF	ON	OFF				4 MOD ARROW
OFF	ON	ON				5 MOD ARROW
ON	OFF	OFF				6 MOD ARROW
ON	OFF	ON				7 MOD ARROW
ON	ON	OFF				8 MOD ARROW
ON	ON	ON				PASSENGER-SIDE EXIT
			ON			DRIVER-SIDE EXIT
			OFF			SPLIT-COLOR ARROW MODULES
				ON		FULL-COLOR ARROW MODULE (DEFAULT)
				OFF		ENABLE WARNING FLASH ON BLUE/WHITE OUTPUT
				ON		DISABLE WARNING FLASH ON BLUE/WHITE OUTPUT FOR TURN SIGNAL FUNCTION



#EMG2000 MAGNUM LED Lightbar 10-30V

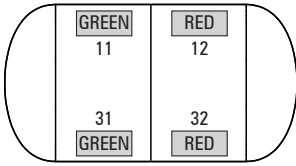

23" BAR

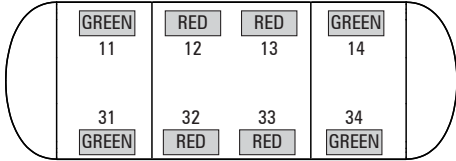

35.5" BAR

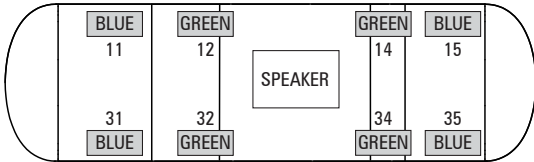

41.8" BAR*

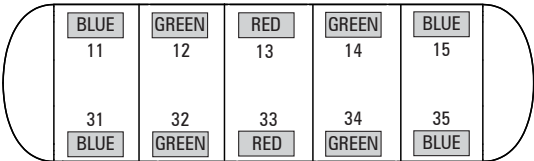

41.8" BAR

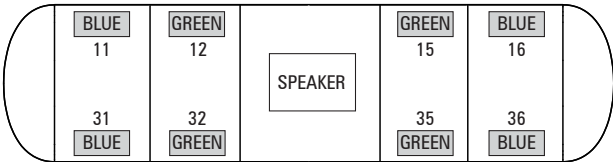

48" BAR*

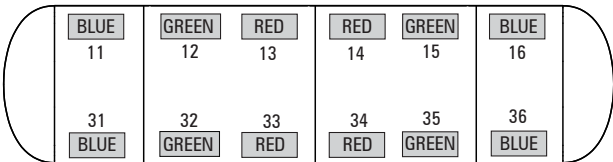

48" BAR

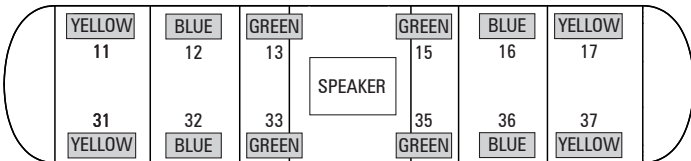

54.3" BAR*

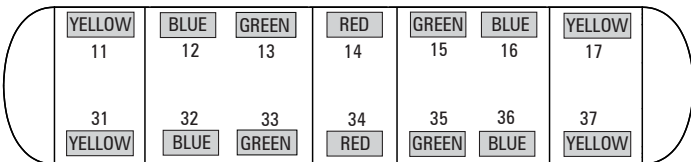

54.3" BAR

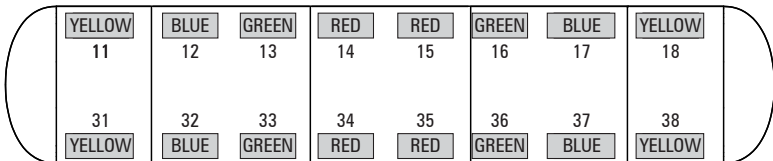

60.5" BAR

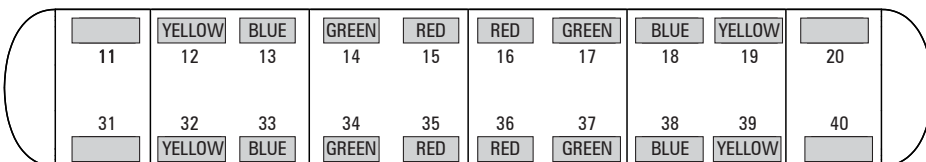

73.0" BAR

*WITH SPEAKER OPTION

LIGHT MODULE WIRE HARNESS LOCATIONS



REPLACEMENT OF INBOARD AND CORNER MODULES:

1. Disconnect main power.
2. Remove top cover by removing screws.
3. Locate module and remove mounting screws. Pull or slide module from lightbar.
4. Remove connector from rear of module by carefully pulling connector body from back of module.
5. Push module connector into replacement module ensuring locking latch is seated properly or connector is fully seated.
6. Replace module and hardware that fasten module to base extrusion.
7. Restore power to bar and test new module to ensure functionality.
8. Replace top cover of bar with screws removed in step 2.

HARNESS REFERENCE:

- Colors shown on left indicate wire colors on wire harness.
- Inboard modules: Color/color (eg. red/red) wires go to front inboard modules, color/white (eg red/white) go to back inboard modules.
- Corner modules: Orange/black wires go to front, red/black wires go to back.
- Split center modules: Follow previous front/back color locations, and connect red wires from each side to the split board "IN" connectors. The "OUT" / "TO MODULE" connector goes to the short adapter wire harness and then the module.
- Takedown modules: Black/red wires with white or black label, NOT SHOWN.
- Alley modules: Black/red wires with blue label, NOT SHOWN.



#EMG2000 MAGNUM LED Lightbar 10-30V

MAGNUM TROUBLESHOOTING

NORMAL OPERATION

Under normal operation with lightbar turned on the breakout box will have the Green and Red LED light on steady. When you change an input to the lightbar the Red LED on the breakout box will flash then go back to steady.

When the lightbar is off (no input active) the Green LED on the breakout box will stay on for 15 seconds then go off putting the lightbar into sleep (standby) mode. The Red LED will flash every 5 seconds to tell you there is power to the breakout box and it is waiting for an input to turn on the lightbar.

NO OPERATION

- No LED on or flashing on Breakout box; Check input power and ground to lightbar, check data cable for damage and/or opens/shorts, check all 4 FH1-FH4 (10A) fuses on the electronic control board in lightbar.
- Breakout box LED's operating correctly; Check all 4 FH1-FH4 (10A) fuses on the electronic control board in lightbar.

NO OR INCORRECT INBOARDS OR CORNER LIGHTS (WARNING)

- Breakout box LED's operating correctly; Check FH1-4 (10A) fuses on the electronic control board in lightbar.
- No steady Red LED on breakout box; Check 24-pin connector at breakout box (**insure it is snapped in correctly**), check appropriate input to breakout box for output lights which should be on
- No rear warning lights; Check that Arrow Warning Wire #9 front Breakout Box is being used if bar is set for arrow (**after arrow dip switch changes main power must be cycled**). Check violet, red or tan lines from discrete harness are connected to +Vdc if applicable.
- No Rear Warning on Blue Outputs Only; Verify Dip Switch setting for SW6 on the ECB in the lightbar is set to ON. Cycle main power after changing any settings.
- Modules(s) stuck on or off; Check module is plugged in and grounded or module power shorted to ground or +Vdc.

NO TAKE DOWNS AUXILLARY OR ALLEY LIGHTS

- Breakout box LED's operating correctly; Check FH1 and FH4 (10A) fuse on the electronic control board in lightbar.
- No steady Red LED on breakout box; Check 24-pin connector at breakout box (**insure it is snapped in correctly**), check appropriate input to breakout box for output lights which should be on.
- Module(s) stuck on or off; Check module is plugged in and grunded or module power shorted to ground or +Vdc.

INCORRECT OR NO ARROW OPERATION

- Breakout box LED's operating correctly; Check dip switches setting on the electronic control board in lightbar (**after arrow dip switch changes main power must be cycled**).
- No steady Red LED on breakout box; Check 24-pin connector at breakout box (**insure it is snapped in correctly**), check appropriate input to breakout box for output lights which should be on.
- Arrow direction incorrect; Change passenger/driver side dip switch SW4 on the electronic control board in lightbar (**after arrow dip switch changes main power must be cycled**).
- 8-wire control not operating; Check dip switch setting SW1-3 (should be off, off, off) on the electronic control board in lightbar (**after arrow dip switch changes main power must be cycled**)
- Rear Modules Incorrect or not operating; Check dip switch SW1-3 for proper arrow setting on the electronic control board in lightbar (**after dip switch changes main power must be cycled**)



#EMG2000 MAGNUM LED Lightbar 10-30V

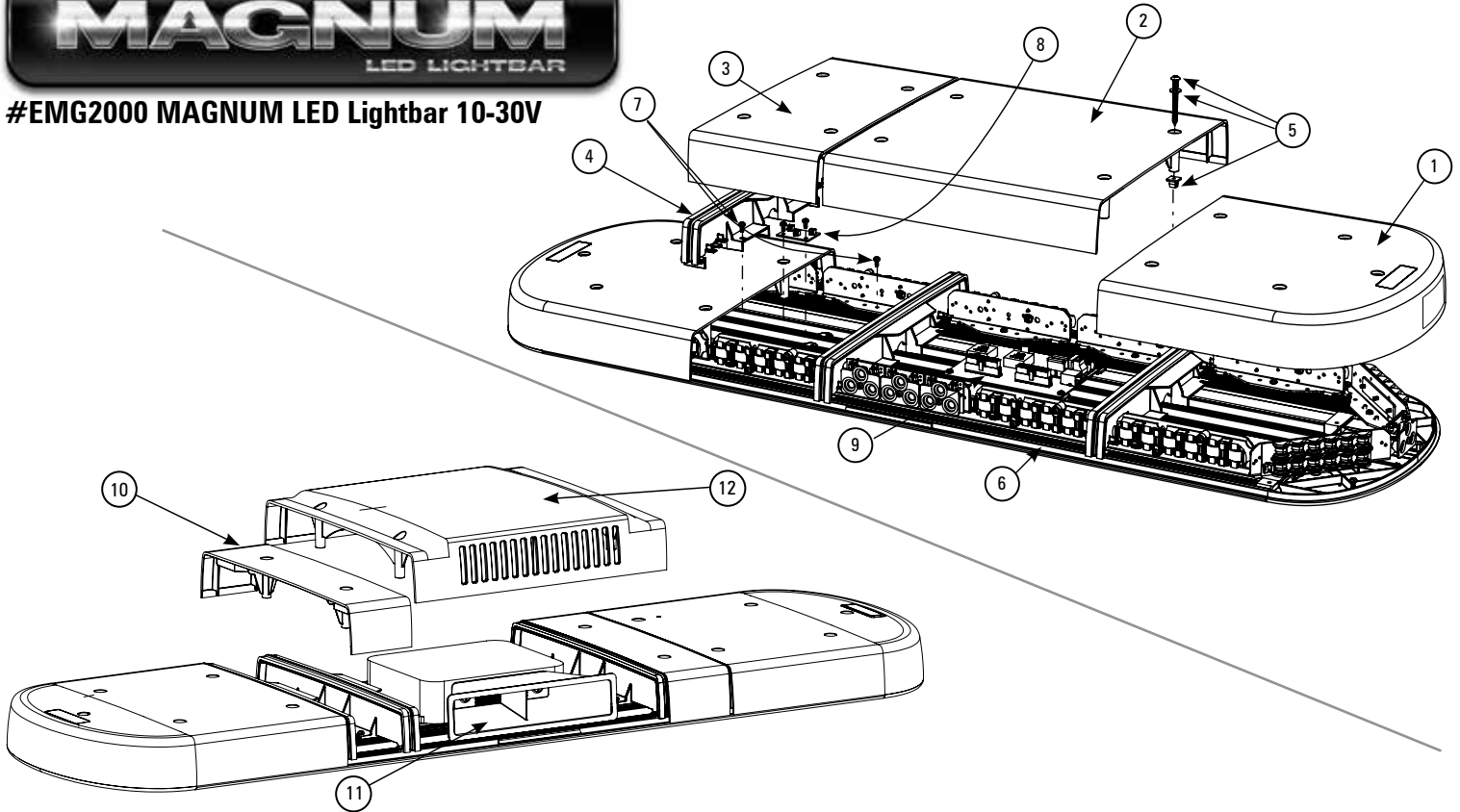

REPLACEMENT PARTS & ACCESSORIES

ITEM #	PART#	DESCRIPTION
	PEMG2K00	EXTRA LOW MOUNTING FOOT KIT
	PESF1K00	LOW PROFILE MOUNTING FOOT - EXT.
	PEMG2K01	PREMIUM FIXED HEIGHT FOOT KIT - STANDARD PAD
	PEMG2K02	PREMIUM FIXED HEIGHT FOOT KIT - EXT
	PENG2K03	PREMIUM FIXED HEIGHT FOOT KIT - THICK PAD
	PETLK06	HEADACHE RACK MOUNT FOOT
	PESF1HK16	FLAT MOUNT HARDWARE KIT
	PETLF(xx)	LOW PROFILE HOOK KITS
	PETLF00	PERMANENT MOUNT HARDWARE KIT
	PETLR(xx)	ROOF RACK HOOK KITS
	PETLJ00	BREAKOUT BOX
	PEPL9BBHNL	BREAKOUT HARNESS LONG
	PEPL9BBHNS	BREAKOUT HARNESS SHORT
	PETLWA978	DATA CABLE
	PEPL9RFGR	ROOF GROMMET
	ETSWDAS01	ARROW CONTROLLER
	PEPX3GA01	BASE T-SLOT GASKET ROUND
9	PEMG2E01	MAINBOARD 10-30V ASSEMBLY
1	PEMG2DECL(x)	ENDCAP LEXAN DOME (COLOR)
1	PEMG2DECX(x)	ENDCAP XYLEX DOME (COLOR)
3	PEMG2DMSL(x)	INNER DOME LEXAN 6" (COLOR)
3	PEMG2DMSX(x)	INNER DOME XYLEX 6" (COLOR)
2	PEMG2DMLL(x)	INNER DOME LEXAN 12" (COLOR)
2	PEMG2DMLX(x)	INNER DOME XYLEX 12" (COLOR)

ITEM #	PART#	DESCRIPTION
3	PEMG2DMSX(x)	INNER DOME XYLEX 6" (COLOR)
2	PEMG2DMLL(x)	INNER DOME LEXAN 12" (COLOR)
2	PEMG2DMLX(x)	INNER DOME XYLEX 12" (COLOR)
10	PEMG2DMML(x)	INNER DOME LEXAN 3" (COLOR)
4	PEMG2DVDLC	DIVIDER (LEXAN/CLEAR)
4	PEMG2DVDXC	DIVIDER (XYLEX/CLEAR)
*	PEMG2AR203W	ALLEY LIGHT MODULE
*	PEMG2HR203W	LED TAKEDOWN/WORK LIGHT (SINGLE)
*	PEMG2HR206W	LED TAKEDOWN/WORK LIGHT (DOUBLE)
*	PEMG2HR209W	LED TAKEDOWN/WORK LIGHT (TRIPLE)
	PEMG2LM203(x)	3" 3 LED INBOARD MODULE (COLOR)
*	PEMG2LR203(x)	6" 3 LED INBOARD MODULE (COLOR)
*	PEMG2LR206(x)	6 LED INBOARD MODULE (COLOR) †
*	PEMG2CR206(x)	6 LED CORNER MODULE (COLOR)
*	PEMG2CC212(x)	12 LED CORNER MODULE (COLOR)
*	PEMG2CE212A	12 LED CORNER MODULE ECE AMBER
8	PEMG2HNSW	SPLIT WARNING JUMPER HARNESS/BOARD
5	PEMG2HDDR	SINGLE DOME REPLACEMENT HARDWARE KIT
6	PEMG2GABS	BASE GASKET (SHORT 10 FEET)
6	PEMG2GABL	BASE GASKET (LONG 14 FEET)
7	PEMG2HDDM	SINGLE DIVIDER/MODULE SCREW KIT
	PEMG2HNMS	MAIN WIRE HARNESS SHORT
	PEMG2HNML	MAIN WIRE HARNESS LONG
11	PEMG2SPKR1	SPEAKER, FLAT FOR MAGNUM LIGHTBAR
12	PEMG2DSPKR	EMG2000 SPEAKER DOME

*SEE PAGE 2 FOR ILLUSTRATIONS & PART NUMBER FOR BOTH SOLID AND SPLIT



#EMG2000 MAGNUM LED Lightbar 10-30V

WARRANTY & RETURN GOODS PROCEDURE

CLEANING & CARE OF YOUR LIGHTBAR:

Keeping the lenses clean and scratch free will optimize the performance of the lightbar. The exterior of the lightbar including lenses should be cleaned with mild soapy water and a soft cotton cloth to remove dirt, grime and insects. Never use window cleaners or harsh chemicals on the lenses; this may cause failure of the lenses or reduce clarity resulting in the reduction of light output.

MOUNTING INTEGRITY:

A review of bolt/hardware/mounting bracket integrity should be performed at the beginning and end of each shift.

WARNING MESSAGES - PLEASE READ: _____

WARNING - DRILLING ANY HOLES INTO THE LIGHTBAR IS NOT RECOMMENDED! THE RISK OF DAMAGING INTERNAL COMPONENTS AND THE RESULTING FAILURE OF THE LIGHTBAR WILL VOID ANY WARRANTY OF THIS PRODUCT.

WARNING - CARE MUST BE TAKEN WHEN DRILLING THROUGH THE ROOF OF THE VEHICLE NOT TO DRILL INTO ANY EXISTING WIRING AND NOT TO DRILL THROUGH THE HEADLINER OR SUPPORT MEMBERS OF THE VEHICLE. CHECK BOTH SIDES OF THE MOUNTING SERVICE PRIOR TO DRILLING. DE-BURR ANY HOLES AND REMOVE ANY METAL SHARDS OR REMNANTS. INSTALL GROMMETS INTO ALL WIRE PASSAGE HOLES.

WARNING - ROUTE WIRES ONLY IN LOCATIONS THAT ARE NOT SUBJECTED TO POTENTIAL WEAR. MAKE SURE TO AVOID ROUTING WIRES IN THE DEPLOYMENT AREA OF YOUR AIR BAG. REFER TO YOUR VEHICLE OWNER'S MANUAL FOR AIR BAG DEPLOYMENT ZONES.

WARNING - ALL CUSTOMER SUPPLIED POWER WIRES CONNECTING TO THE POSITIVE (+) OR NEGATIVE (-) BATTERY TERMINAL OR LOCAL CHASSIS GROUND (-) MUST BE SIZED TO SUPPLY AT LEAST 125% OF THE MAXIMUM CURRENT AND PROPERLY FUSED AT THE POWER SOURCE WITH APPROPRIATELY RATED FUSE.

IMPORTANT: When passing cables through fire wall or other sheet metal, insert grommet to protect the cable!

WARRANTY RETURN PROCESS:

Please contact your SoundOff Signal Sales Representative, Customer Services staff or our Technical Department (800.338.7337) for a RMA #, Return Merchandise Authorization Number.

The following information is required for issuance of the RMA #:

- Reason for returning the product*
- Address where replacement product is to be shipped*
- Telephone number where you may be reached*
- SoundOff Signal invoice number on which product was purchased**
- SoundOff Signal part number and serial number**
- E-mail address where RMA # should be e-mailed**
- Fax number where RMA # should be faxed**

* RMA # will not be given without this information.

** If available, please provide this information.

SoundOff Signal will NOT accept returns without an RMA #. Each RMA # is good for only one (1) return and will expire (30) days after the date it was issued. Products must be shipped back to SoundOff Signal and the RMA # clearly marked on the outside of the package near the shipping label. Please use the following address on your shipping label:

SoundOff Signal
ATTN: RMA # / Technical Services
3900 Central Parkway
Hudsonville, MI 49426

WARRANTY EXCLUSIONS:

Shipping & Handling, labor and service fees are non-refundable. SoundOff Signal is not liable for any damage due to installation or personal injury as a result of using SoundOff Signal product.

WARRANTY FORFEITURE:

Warranty will not be granted if the Warranty Return Policy & Procedure rules are not strictly followed. Physical damage resulting from customer abuse will void warranty. Warranty will also be voided if any SoundOff Signal and/or manufacturer serial tags, product stickers, seals, or the like, are removed, altered or tampered with. Returned product that is damaged by shipping via the RMA # procedure is not the responsibility of SoundOff Signal.

Document effective date on cover and below supersedes previously dated policies and statements.

There are no other warranties, expressed or implied, including, but not limited to, any implied merchantability or fitness for a particular use. SoundOff Signal reserves the right to modify this warranty statement at any time; or to discontinue, modify, or upgrade any products of its manufacture with design improvements without prior notice.

NOTICE:

Installers and users must comply with all applicable federal, state and local laws regarding use and installation of warning devices.

Improper use or installation may void warranty coverage.

*To review our Limited Warranty Statement & Return Policy for this or any SoundOff Signal product, visit our website at www.soundoffsignal.com/tech-services/returns/. If you have questions regarding this product, contact **Technical Services**, Monday - Friday, 8 a.m. to 5 p.m. or after hours 5 p.m. to 8 p.m. ET at **1.800.338.7337** (press #4).*

Questions or comments that do not require immediate attention may be emailed to techservices@soundoffsignal.com.

SUPERIOR CUSTOMER RELATIONSHIPS. SMARTLY DESIGNED LIGHTING & ELECTRONIC SOLUTIONS.