

SAE Class 1 LED Beacon

ELB42BM(z) + (x)(y) Magnet Mount

ELB42BC(z)Ø(x)(y) Flat/Pipe Mount

MAGNET MOUNT
ELB42BM(z) + (x)(y)



FLAT MOUNT / PIPE MOUNT
ELB42BC(z)Ø(x)(y)



ARROW
"REAR OF VEHICLE"

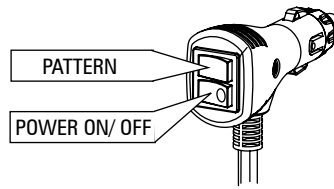

PATTERN

POWER ON/OFF

⚠ WARNING

Please see reverse for Technical Specifications

- HIGH CURRENT interconnects must be properly terminated. Poor crimp quality can cause heat build-up and fire. Follow crimp connector manufacturer instructions.
- DO NOT install this product or route any wires in the Air Bag Deployment Zone. Refer to vehicle Owner's Manual for deployment zones.
- Do NOT use system to disconnect headlights, brake lights or other safety equipment.
- Unit may become hot to touch during normal operation.
- Failure to properly install connectors, fuses or wiring may cause vehicle failure or fire.
- Installation must only be performed by trained technician. Installer must determine vehicle wiring configuration and proper integration of system.
- Use proper wire gauge. All power wires connecting to positive (+) or negative (-) battery terminal or local chassis ground (-) must be sized to supply at least 125% of max. current and properly fused at power source.
- Install protective grommets when routing wire through firewall or metal.

SoundOff
Signal

1.800.338.7337 / www.soundoffsignal.com

INSTALLATION:

Flat Mount

- 1) Determine location where beacon is to be installed and drill 1/2" diameter hole at the center for cord exit.
- 2) Using the housing as a guide, mark the centers of hole positions in three places and drill appropriate pilot holes.
- 3) With wire through center of gasket, make electrical connections.
- 4) Ensure rear cord exit is in correct position and install 3 screws, being careful not to strip out pilot holes. DO NOT OVERTIGHTEN.

Pipe Mount

- 1) Feed wires through pipe and make electrical connections.
- 2) Screw base of beacon to pipe (clockwise.)

Beacon may be installed on a vertical pipe with 1" NPT thread.

⚠ WARNING

This product contains high intensity LED devices. To prevent eye damage, DO NOT stare into the light beam at close range.

NOTICE:

Installers and users must comply with all applicable federal, state and local laws regarding use and installation of warning devices.

Improper use or installation may void warranty coverage.

To review our Limited Warranty Statement & Return Policy for this or any SoundOff Signal product, visit our website at www.soundoffsignal.com/tech-services/returns/. If you have questions regarding this product, contact **Technical Services**, Monday - Friday, 8 a.m. to 5 p.m. or after hours 5 p.m. to 8 p.m. ET at 1.800.338.7337 (press #4). Questions or comments that do not require immediate attention may be emailed to techservices@soundoffsignal.com.

OPERATION:

Magnet Mount

- 1) Place beacon on roof of vehicle.
- 2) Route wire through window.
- 3) Plug into 12V socket.
- 4) Refer to diagram at left for POWER ON/OFF switch and Pattern Select switch locations.
- 5) Turn beacon ON by pressing the POWER ON/OFF switch to the ON position.
- 6) With beacon ON, momentarily press PATTERN SELECT switch to change pattern.
- 7) Press and hold Pattern switch for 5 seconds for master reset.

Flat / Pipe Mount

- 1) Connect wires as shown below and should be taped after pattern is selected.

NOTE: THE WHITE WIRE, USED FOR PATTERN SELECTION, IS FOR MOMENTARY TO 12VDC.

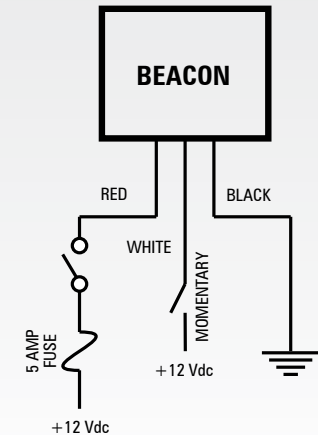

SUPERIOR CUSTOMER RELATIONSHIPS. SMARTLY DESIGNED LIGHTING & ELECTRONIC SOLUTIONS.

SAE Class 1 LED Beacon

ELB42BM(z) + (x)(y) Magnet Mount

ELB42BC(z)Ø(x)(y) Flat/Pipe Mount

Flash Patterns				
Alternating Patterns	1 Light	Simultaneous 2 Lights	X-Pattern 4 Lights	FPM (Flashes per Minute)
1. Warp	x	x		240
2. Quad Flash	x	x		81
3. Quint	x	x		71
4. Double Flash	x	x		71
5. Quad2 Flash	x	x		67
6. Warp ²	x	x		59
7. E-Ideal Single Flash	x	x		63
8. U ²	x	x		135
9. Power Pulse	x	x		182
10. Road Runner	x	x		113
11. Slow Runner	x	x		70

Factory Default Setting

Replacement Parts & Accessories:

E36ØBG4: Metal Branch Guard for 4" Low Dome
 E36ØBG6: Metal Branch Guard for 6" High Dome
 E36ØDC6: Clear Dust Cover for 4" Low and 6" High Dome
 ET2BLL(x): Replacement 4" Low Dome
 ET2BLT(x): Replacement 6" High Dome
 PE2BBDR2: Black Dress Ring

TECHNICAL SPECIFICATIONS	
Overall Dimensions:	4.86"H x 6.35"n
Flash Patterns:	11 flash patterns
Input Voltage Range:	9 - 30 Vdc
Current Consumption:	less than 2 amps
# of LEDs:	8 Generation 4 LEDs
Light Sync Technology:	Yes
Operating Temperature:	-40° to +65° C
Cord Length Permanent:	18"
Cord Length Magnetic:	140"

BEACON LIGHT SYNC CONFIGURATION INSTRUCTIONS:

Set Pattern

- 1) With power connected and light flashing, momentarily tap WHITE wire to 12 Vdc
- 2) Repeat until desired pattern is reached

Reset Pattern

- 1) Apply WHITE (sync) wire to 12 Vdc for 5 seconds to select Factory Default Setting
- 2) Remove WHITE wire to terminate

NOTE: SYNC IS AVAILABLE FOR SIMULTANEOUS FLASHING ONLY, NOT ALTERNATING

NOTICE:

Installers and users must comply with all applicable federal, state and local laws regarding use and installation of warning devices.

Improper use or installation may void warranty coverage.

To review our Limited Warranty Statement & Return Policy for this or any SoundOff Signal product, visit our website at www.soundoffsignal.com/tech-services/returns/.
 If you have questions regarding this product, contact **Technical Services**, Monday - Friday, 8 a.m. to 5 p.m. or after hours 5 p.m. to 8 p.m. ET at 1.800.338.7337 (press #4).

Questions or comments that do not require immediate attention may be emailed to techservices@soundoffsignal.com.

SUPERIOR CUSTOMER RELATIONSHIPS. SMARTLY DESIGNED LIGHTING & ELECTRONIC SOLUTIONS.

1.800.338.7337 / www.soundoffsignal.com