

LED3 MINI LIGHTBAR MAGNET MOUNT

EL3MBM+(x)C

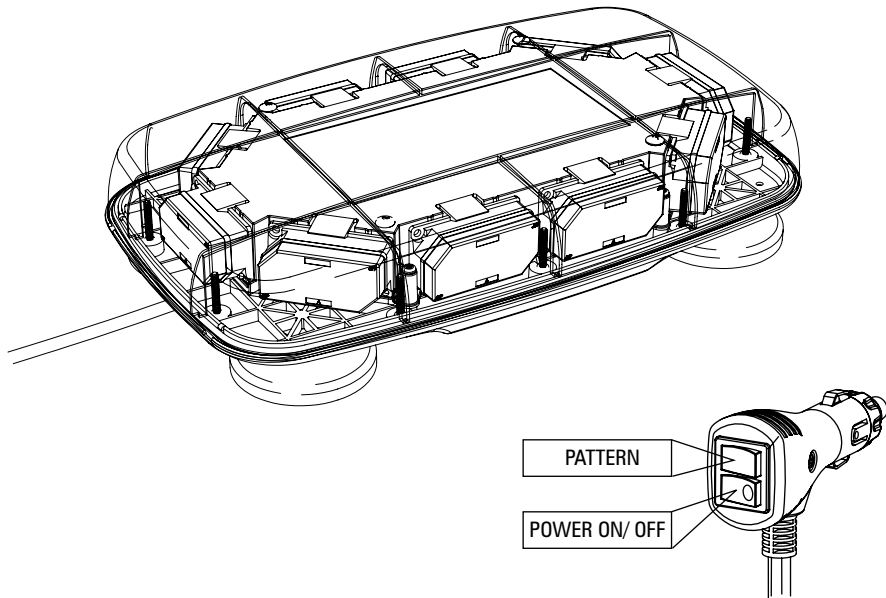

⚠ WARNING

Please see reverse for Technical Specifications

- HIGH CURRENT interconnects must be properly terminated. Poor crimp quality can cause heat build-up and fire. Follow crimp connector manufacturer instructions.
- DO NOT install this product or route any wires in the Air Bag Deployment Zone. Refer to vehicle Owner's Manual for deployment zones.
- Do NOT use system to disconnect headlights, brake lights or other safety equipment.
- Unit may become hot to touch during normal operation.
- Failure to properly install connectors, fuses or wiring may cause vehicle failure or fire.
- Installation must only be performed by trained technician. Installer must determine vehicle wiring configuration and proper integration of system.
- Use proper wire gauge. All power wires connecting to positive (+) or negative (-) battery terminal or local chassis ground (-) must be sized to supply at least 125% of max. current and properly fused at power source.
- Install protective grommets when routing wire through firewall or metal.

INSTALLATION:

- 1) Determine a clean, flat location (typically the roof) on the vehicle to mount the LED3 Mini Lightbar. The LED3 Mini Lightbar comes equipped with four magnetic feet. It is the responsibility of the installer and end user to determine whether it is safe to use magnetic mounting hardware for your application. A Permanent Mount version (EL3MBP+(x)C) is available. Note: The magnetic character of roof steel varies from vehicle to vehicle. Be sure that your vehicle is capable of providing enough magnetic force to safely secure the LED3 Mini Lightbar to the roof.
- 2) A Protective Film has been provided with the LED3 Mini Lightbar kit that can be applied to the bottom of each magnet. This film will protect the paint of the vehicle. Apply one donut shaped decal to the bottom of each magnetic foot. Be sure to cover the magnet entirely for maximum protection to the paint finish. Note: Protective film can reduce the magnetic force by as much as 10%.

OPERATION:

Electrical Connections
& Flash Pattern Selection:

See diagram at left for Power ON, Power OFF and Pattern SELECT switch positions. Turn the light on by pressing the Power ON button. To change the flash pattern press and hold the PATTERN SELECT button for one to two (1-2) seconds. The LED3 Mini Lightbar will advance one (1) flash pattern and flash the new pattern each time this is done. The LED3 Mini Lightbar features non-volatile memory and will recall last pattern used. Selected pattern will remain the default once turned off and can be changed by changing the flash pattern before powering off.

⚠ WARNING

This product contains high intensity LED devices.
To prevent eye damage, DO NOT stare into the
light beam at close range.

NOTICE:

Installers and users must comply with all applicable federal, state and local laws regarding use and installation of warning devices.

Improper use or installation may void warranty coverage.

To review our Limited Warranty Statement & Return Policy for this or any SoundOff Signal product, visit our website at www.soundoffsignal.com/tech-services/returns/. If you have questions regarding this product, contact **Technical Services**, Monday - Friday, 8 a.m. to 5 p.m. or after hours 5 p.m. to 8 p.m. ET at 1.800.338.7337 (press #4).

Questions or comments that do not require immediate attention may be emailed to techservices@soundoffsignal.com.

SUPERIOR CUSTOMER RELATIONSHIPS. SMARTLY DESIGNED LIGHTING & ELECTRONIC SOLUTIONS.

SoundOff Signal

1.800.338.7337 / www.soundoffsignal.com

LED3 MINI LIGHTBAR MAGNET MOUNT

EL3MBM+(x)C

Replacement Parts & Accessories:

PMB3BMG: Replacement Magnetic Foot (each)

PMB3MGKT: Replacement Magnetic Mount (kit)

PMB3TDC: Replacement Clear Dome

PMB3M-20(x): Replacement LED3 Module (see website for colors)

PMB3M-45(x): Replacement LED3 Corner Module (see website for colors)

TECHNICAL SPECIFICATIONS	
Overall Dimensions:	14.25"L x 8.27"W x 2.93"H
Flash Patterns:	24 flash patterns
Input Voltage Range:	10 - 16 Vdc
Current Consumption:	<6 Amps
# of LEDs:	30 Generation 3 LEDs
Operating Temperature:	-40° to +65° C
Cord Length:	125.75"



WARNING

Damages or injury may occur from improper use of a lighting product intended for vehicle use.

Auxiliary vehicle lighting products, when used on highway use vehicles, are always recommended to use secure, permanent mounting for maximum safety. In some instances, a more temporary vehicle attachment, such as optional magnet mounting (lighting product vehicle retention is based on magnets on the lighting product to the vehicle's steel/ferrous flat metal components) is offered. The effectiveness of magnet mounting is reduced by factors that include the contour, texture, curvature, snow, ice, and general cleanliness of the mounting location, and also with newer vehicle non-magnetic metal such as aluminum. Due to the potential for low effective magnetic mount retention, it is recommended to use magnets for stationary vehicle use. High driving speeds, rapid accelerations, or rapid decelerations (including accidents or rough road conditions or weather related conditions) may cause a magnet mounted light to unexpectedly detach from the vehicle.

It is the sole responsibility of the user to ensure proper mounting and safe operating conditions and end user awareness of the safe operating conditions.

Flash Patterns	
Alternating Patterns	FPM (Flashes per Minute)
1. Warp	353
2. Quad	81
3. Quad2	67
4. Quint	71
5. Double2	95
6. Warp 1, 2, 3	variable
7. Progressive	variable
8. Q-Switch	variable
9. Intercycle	variable
Solid Patterns	FPM
10. Warp	176
11. Quad	41
12. Quad2	34
13. Quint	35
14. Double2	48
15. Warp 1, 2, 3	variable
16. Progressive	variable
Rotating Patterns	FPM
17. 1x1 Rotator	545
18. 2x2 Rotator	545
19. 9-1 Rotator	600
Random Patterns	FPM
20. Quint (corners & ends)	71
21. Quad (in & out)	81
22. Rotating Alternating	375
23. Cycle 1	variable
24. Cycle 2	variable

NOTICE:

Installers and users must comply with all applicable federal, state and local laws regarding use and installation of warning devices.

Improper use or installation may void warranty coverage.

To review our Limited Warranty Statement & Return Policy for this or any SoundOff Signal product, visit our website at www.soundoffsignal.com/tech-services/returns/. If you have questions regarding this product, contact **Technical Services**, Monday - Friday, 8 a.m. to 5 p.m. or after hours 5 p.m. to 8 p.m. ET at 1.800.338.7337 (press #4).

Questions or comments that do not require immediate attention may be emailed to techservices@soundoffsignal.com.

SUPERIOR CUSTOMER RELATIONSHIPS. SMARTLY DESIGNED LIGHTING & ELECTRONIC SOLUTIONS.

SoundOff Signal

1.800.338.7337 / www.soundoffsignal.com