

GHOST

STEADY ON GHOST™ DUAL LIGHT

EGHDS1(x) - Black

EGHDS1(x)W - White

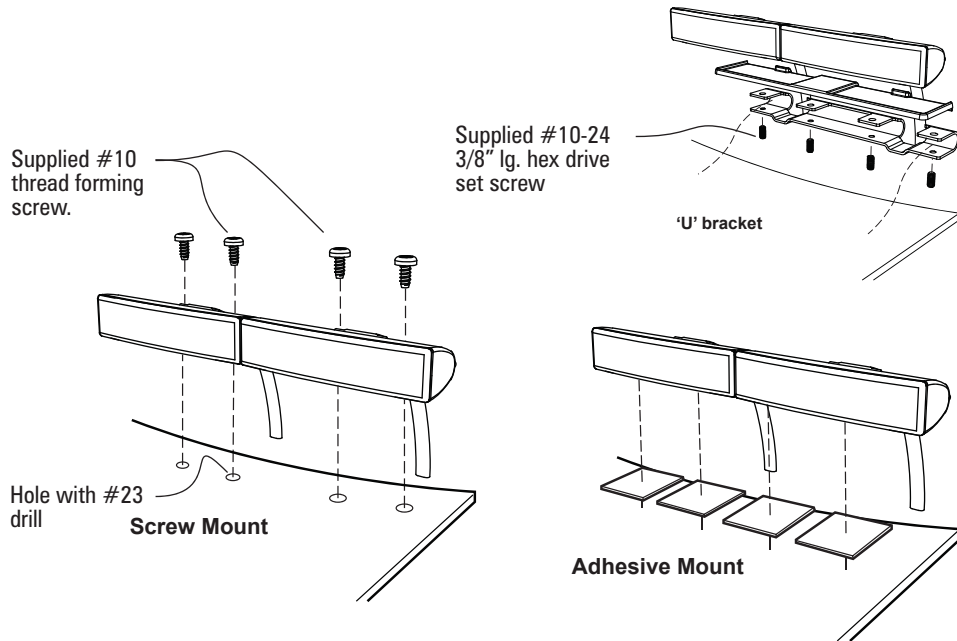

Important Information:

- DO NOT install this product or route any wires in the Air Bag Deployment Zone. Refer to your vehicle Owner's Manual for the location of any air bag deployment zones.
- DO NOT connect this device to a strobe power supply. This product is self-contained and does not require an external power supply.



INSTALLATION:

1. **Screw Mount** - Establish a position on the vehicle. Use the mounting slots as a template to mark hole locations. Drill a hole using a #23 drill bit. The Torx screws provided are self-tapping.

2. **Adhesive Mount** - To obtain optimum adhesion, the bonding surfaces must be well uni ed, clean and dry. Peel one side of each adhesive mounting patch provided. Apply each rectangular patch to the bottom of the GHOST housing. Position the GHOST on the vehicle and mark 2 edges of the location using tape. Peel the remaining paper from the adhesive patch and carefully position the light using the tape template. Press down on housing rrmly to insure good adhesive contact. Important: Apply carefully; adjustment is not possible after the adhesive bonds. Ultimate strength of adhesive is achieved after 24 hours.

3. **'U' bracket** - Open the hood or trunk that will be the attachment surface. Place the rubber pad provided on the surface, insuring that the lower lip is on the edge of the sheet metal. Fit the 'U' bracket to the back of the GHOST light base, nesting the bracket holes with the pins on the light base. Slide the assembly onto the rubber pad. Tighten the four set screws.

Loosen the two #10 TORX screws on the back of each housing to adjust the angle of the GHOST. After adjustment, tighten the TORX screws.

WIRE HOOK-UP TABLE

WIRE COLOR:	CONNECT TO:
RED	+ 10-30Vdc
BLACK	Ground (-)
WHITE	+ 10-30Vdc

OPERATION:

WIRE CONNECTIONS

1. Connect the GHOST™ BLACK wire to a good, convenient ground.
2. Connect the GHOST™ RED and WHITE wire to one side of a user supplied on/off switch. Connect the other side of the switch, through a 3Amp fuse, to a source of + 10-30Vdc. Both RED and WHITE wires **MUST** be connected to power.

NOTE: The GHOST™ is a factory sealed unit that CANNOT be serviced in the field. Any attempt to gain access to the GHOST™ unit will most likely cause permanent damage and void its warranty.

SLAVE MODE

GHOST does not support Slave Mode.

TECHNICAL SPECIFICATIONS

Overall Dimensions:	8.0"L x 0.88"H x 1.75"D
Input Voltage Range:	10-30Vdc
Current Consumption:	0.45A @ 12.8Vdc 0.23 @ 25.6Vdc
# of LEDs:	6 Generation 3 LEDs
Operating Temperature:	-40° to +65° C

⚠ WARNING

This product contains high intensity LED devices. To prevent eye damage, DO NOT stare into light beam at close range.

To review our Limited Warranty Statement & Return Policy for this or any SoundOff Signal product please visit our website at www.soundoffsignal.com and select the "Warranty & Returns" link along the left column of our home page. If you have questions regarding this product please contact Technical Services, Monday - Friday, 8 am to 5 pm at 1.800.338.7337, press #4 to skip the automated message. Questions or comments that do not require immediate attention may be emailed to techsupport@soundoffsignal.com.

1.800.338.7337. / www.soundoffsignal.com / Thank you for trusting us with your safety!