

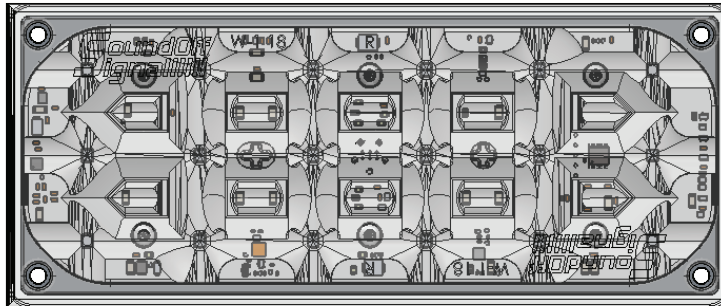

with Clear Duty® Technology

**7x3 BACKUP LIGHT**

EMPSC07M(x)-(x) - Quick Mount, Screw Mount, & Stud Mount



**⚠ WARNING**

- HIGH CURRENT interconnects must be properly terminated. Poor crimp quality can cause heat build-up and fire. Follow crimp connector manufacturer instructions.
- DO NOT install this product or route any wires in the Air Bag Deployment Zone. Refer to vehicle Owner's Manual for deployment zones.
- Unit may become hot to touch during normal operation.
- Failure to properly install connectors, fuses or wiring may cause vehicle failure or fire.
- Installation must only be performed by trained technician. Installer must determine vehicle wiring configuration and proper integration of system.
- Use proper wire gauge. All power wires connecting to positive (+) or negative (-) battery terminal or local chassis ground (-) must be sized to supply at least 125% of max. current and properly fused at power source.
- Install protective grommets when routing wire through firewall or metal.

**NOTICE:**

Installers and users must comply with all applicable federal, state and local laws regarding use and installation of warning devices.

*Improper use or installation may void warranty coverage.*

To review our Limited Warranty Statement & Return Policy for this or any SoundOff Signal product, visit our website at [www.soundoffsignal.com/tech-services/returns/](http://www.soundoffsignal.com/tech-services/returns/).

If you have questions regarding this product, contact **Technical Services**, Monday - Friday, 8 a.m. to 5 p.m. ET at **1.800.338.7337** (press #4).

Questions or comments that do not require immediate attention may be emailed to [techservices@soundoffsignal.com](mailto:techservices@soundoffsignal.com).

**MPOWER® 7X3 BACKUP LIGHT  
TECHNICAL SPECIFICATIONS**

Input Voltage:	9-32Vdc			
<b>7X3 BACKUP LIGHT WITH WARNING CURRENT CONSUMPTION (Amps)</b>				
	12.8Vdc		25.6Vdc	
	<b>Peak</b>	<b>Average</b>	<b>Peak</b>	<b>Average</b>
<b>Red</b>	1.20	0.60	0.60	0.30
<b>Amber, Blue, Green or White</b>	1.44	0.72	0.72	0.36

<b>7X3 BACKUP LIGHT CURRENT CONSUMPTION (Amps)</b>		
	12.8Vdc	25.6Vdc
	<b>Peak</b>	<b>Peak</b>
<b>HIGH (SINGLE)</b>	0.76	0.38
<b>LOW (DUAL)</b>	0.38	0.19

**AFTER POWER IS ON**, touching the WHITE wire to the ground will allow you to change various settings on the module. (refer to page 5.)

**⚠ WARNING**

This product contains high intensity LED devices. To prevent eye damage, DO NOT stare into the light beam at close range.



1.800.338.7337 / [www.soundoffsignal.com](http://www.soundoffsignal.com)

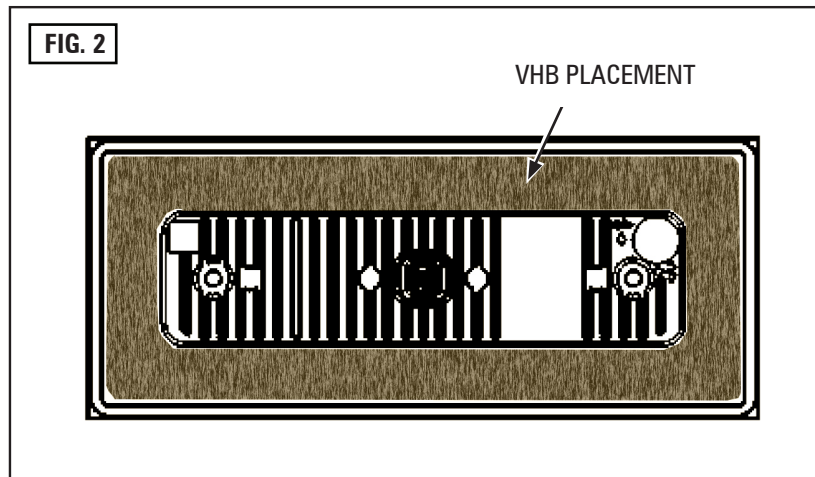
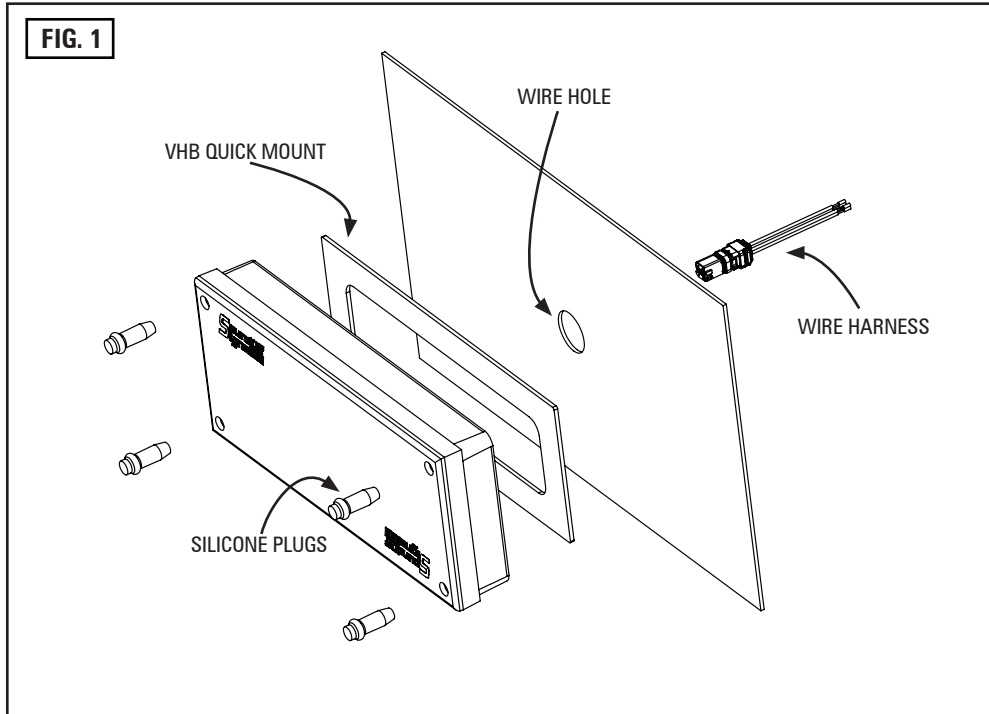

## QUICK MOUNT INSTALLATION

1. Drill a 3/4" wire hole.
2. Insert (4) silicone plugs into light to seal screw holes.

**NOTE: Coating the exterior of the plug in 50% isopropyl alcohol, 50% water mix (Hand sanitizer works well) will allow the plug to slip into place easier, and the mixture will evaporate out leaving no residue**

3. Prep the back of the light and vehicle mount surfaces with 50% deionized water, 50% isopropyl alcohol wipe, and allow to dry.
4. Adhere VHB quick mount to the back of the light and press down firmly for 15 seconds on full surface. See Fig. 2
5. Pull the wire harness through the vehicle wire hole and plug into the back of the light.
6. Lightly place the light against vehicle mount surface and check the alignment is satisfactory. Once alignment is correct press firmly against light for 15 seconds to set VHB quick mount.

**NOTE: Bezel will not work with the Quick Mount option.**

## QUICK MOUNT PART NUMBERS

EMPSC07M4-(x)\* - Backup Light with Warning, Quick Mount

EMPSC07M4-W - Backup Light, Quick Mount

\* (x) Refers to the color of the light.

F = Amber/White

E = Blue/White

D = Red/White

with Clear Duty® Technology

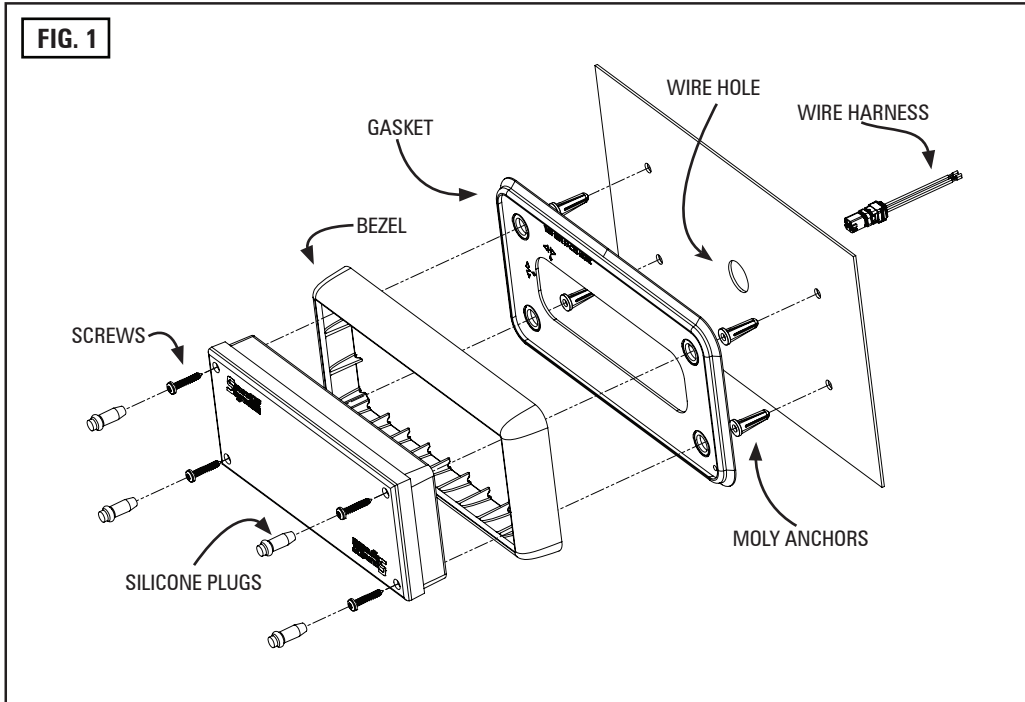
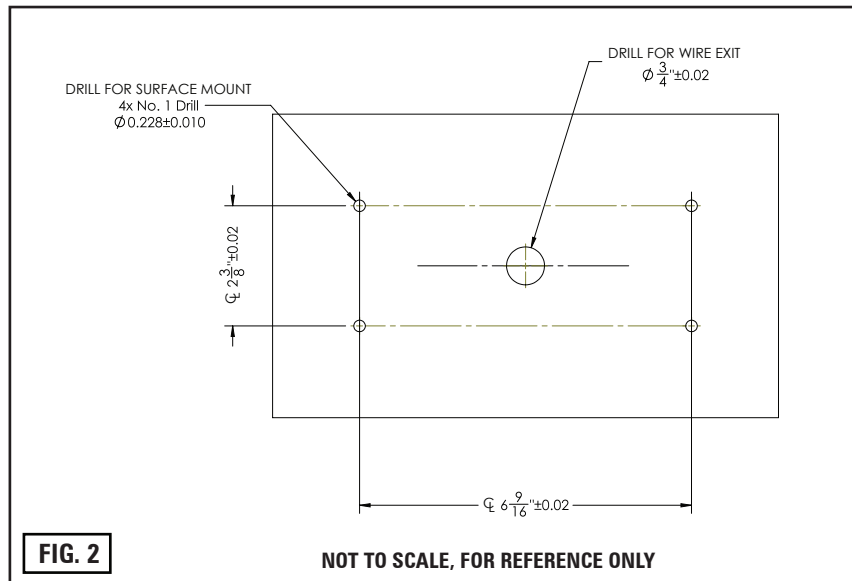

FIG. 1



## SCREW MOUNT INSTALLATION

1. Drill (4) 0.228 (#1 Drill) holes to mount light. Drill 3/4" wire hole. See Fig. 2
2. Insert the moly anchors into the 4 drilled holes. Fully seat to mounting surface.
3. Align the gasket to the mounting surface.

**NOTE: Horizontal and vertical orientations indicated on gasket for proper seal.**

4. Place the bezel over gasket.
5. Pull the wire harness through the opening and plug into the back of the light.
6. Place the light into bezel, press firmly to make sure bezel and gasket are tight against mounting surface.
7. Secure the light to mounting surface using (4) supplied screws.

**NOTE: Tighten until gasket is compressed. DO NOT over tighten and strip moly anchors.**

8. Insert (4) silicone plugs into light to seal screw holes.

**NOTE: Coating the exterior of the plug in 50% isopropyl alcohol, 50% water mix (Hand sanitizer works well) will allow the plug to slip into place easier, and the mixture will evaporate out leaving no residue**



**DO NOT USE POWER TOOLS TO TIGHTEN**

## SCREW MOUNT PART NUMBERS

EMPSC07ME-(x) - Backup Light with Warning, Screw Mount\*  
EMPSC07MC-W - Backup Light, Screw Mount

\* (x) Refers to the color of the light.  
F = Amber/White  
E = Blue/White  
D = Red/White

with Clear Duty® Technology

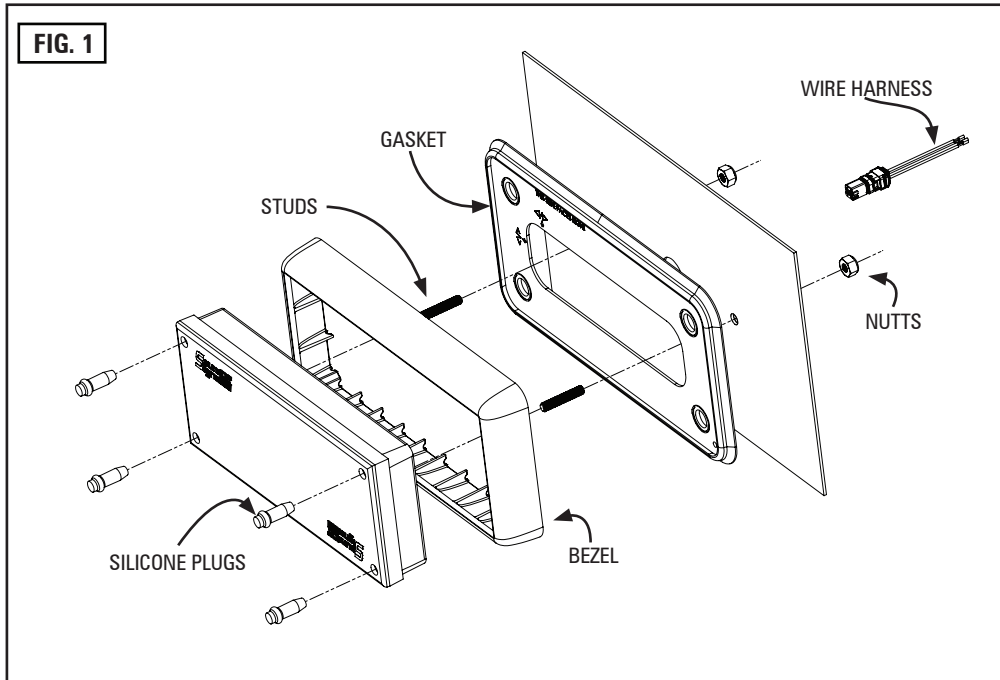
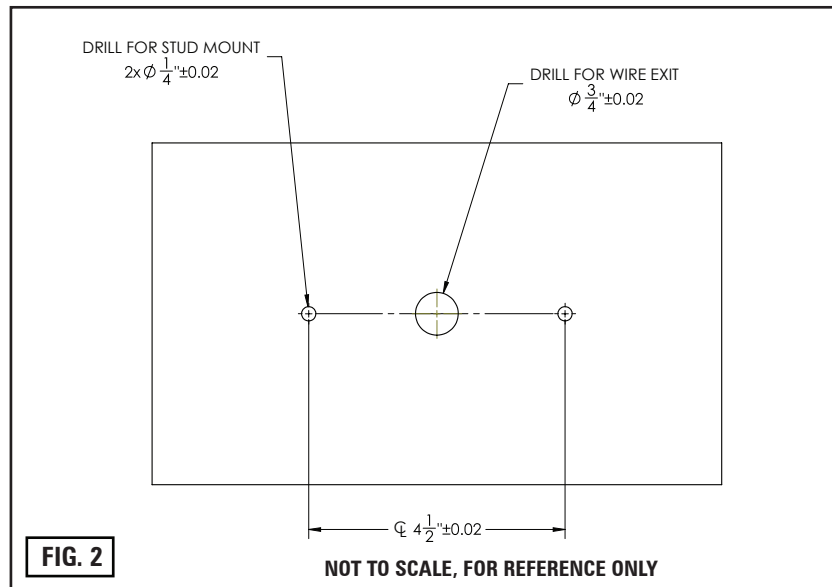

FIG. 1



## STUD MOUNT INSTALLATION

1. Drill (2) 1/4" holes to mount light. Drill 3/4" wire hole. See Fig. 2
2. Insert (4) silicone plugs into light to seal screw holes.

**NOTE: Coating the exterior of the plug in 50% isopropyl alcohol, 50% water mix (Hand sanitizer works well) will allow the plug to slip into place easier, and the mixture will evaporate out leaving no residue**

3. Thread studs into the back of light.
4. Align the gasket to the mounting surface.

**NOTE: Horizontal and vertical orientations indicated on gasket for proper seal.**

5. Place the bezel over gasket.
6. Place the light into bezel, press firmly to make sure bezel and gasket are tight against mounting surface.
7. Secure the light to mounting surface using (2) supplied nuts.

**NOTE: Tighten until gasket is compressed. DO NOT over tighten and strip casting threads.**

8. Pull the wire harness through the opening and plug into the back of the light.



**DO NOT USE POWER TOOLS TO TIGHTEN**

## STUD MOUNT PART NUMBERS

EMPSC07MN-(x) - Backup Light with Warning, Stud Mount\*  
EMPSC07MM-W - Backup Light, Stud Mount

\* (x) Refers to the color of the light.  
F = Amber/White  
E = Blue/White  
D = Red/White

### OVER-VOLTAGE PROTECTION

When an over-voltage condition is detected, the module will flash an over-voltage warning pattern of 50ms ON/950ms OFF to alert of the over-voltage condition and protect the electronics from damage due to heat/voltage.

### THERMAL COMPENSATION PROTECTION

The LED module is designed to provide maximum power output while providing protection to the electronic components by reducing the output power at extreme temperatures.

FUNCTION TABLE				
WIRE			LIGHT	
RED	ORANGE	WHITE	BACKUP LIGHT WITH WARNING	BACKUP LIGHT ONLY
+9-32V			FLASH WARNING COLOR	STEADY BACKUP HIGH POWER
	+9-32V		STEADY BACKUP HIGH POWER	STEADY BACKUP LOW POWER
+9-32V	+9-32V		STEADY BACKUP HIGH POWER	STEADY BACKUP HIGH POWER
		+9-32V	NO OP	NO OP
+9-32V		+9-32V	FLASH WARNING COLOR LOW POWER	STEADY BACKUP HIGH POWER
	+9-32V	+9-32V	STEADY BACKUP LOW POWER	STEADY BACKUP LOW POWER
+9-32V	+9-32V	+9-32V	STEADY BACKUP LOW POWER	STEADY BACKUP HIGH POWER

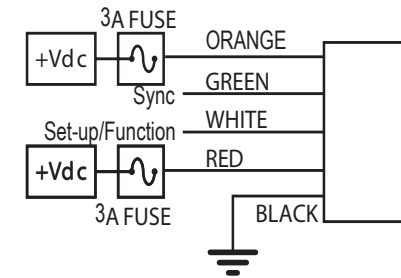

### REMOTE MODE: FOR USE WITH bluePRINT® SYSTEM ONLY

Connecting the Green wire to ground before applying power to the Red or Orange wires will place the LED module into remote mode and the light output color will be directly controlled by the input wires as shown below.

For Cruise mode or Low Power control of the LED module, the signal to the control wires must be 100 +/- 2Hz using the duty cycle inputs listed below to produce the light output.

MPOWER® 7x3 BACKUP LIGHT ONLY REMOTE NODE FUNCTIONALITY		
RED	ORANGE	LIGHT
CRUISE		CRUISE BACKUP COLOR
FLASH		FLASH BACKUP COLOR
STEADY		STEADY BACKUP COLOR

MPOWER® 7x3 BACKUP LIGHT WITH WARNING REMOTE NODE FUNCTIONALITY		
RED	ORANGE	LIGHT
CRUISE	-	CRUISE WARNING COLOR
-	CRUISE	CRUISE BACKUP COLOR
CRUISE	CRUISE	CRUISE BACKUP COLOR
FLASH	-	FLASH WARNING COLOR
-	FLASH	FLASH BACKUP COLOR
FLASH	FLASH	FLASH BACKUP COLOR
STEADY ON	-	STEADY WARNING COLOR
-	STEADY ON	STEADY BACKUP COLOR
STEADY ON	STEADY ON	STEADY BACKUP COLOR
CRUISE	FLASH	FLASH BACKUP COLOR

Cruise Mode Duty Cycle (@ 100Hz)	
Input	Light Output
40%	OFF
50%	5%
60%	10%

Low Power Flash D.C. (@ 100Hz)	
Input	Light Output
70%	30%
80%	40%
90%	50%

with Clear Duty<sup>®</sup> Technology

**FOR THE 7X3 BACKUP LIGHT WITH WARNING ONLY**

**SIMULTANEOUS/ALTERNATE**

This function can only be changed when the LED module is in a flashing mode (disabled in cruise or steady ON functions) and only has an effect when at least 2 LED modules have the green sync wire connected together. When the light is flashing, momentarily connect the white wire to ground for >3S and <4S (light will go steady high, steady low, off, steady high) then release. The light module will switch between Simultaneous and Alternate each time this sequence is done. To have light modules flash simultaneously, both light modules need to be set to the same sequence type (Set-Up Table). To have light modules flash alternately, the light modules need to be set to different sequence types (Set-Up Table).

**ADVANCE PATTERN**

Flash pattern can only be changed when the LED module is in a flashing mode (disabled in cruise or steady ON functions). When the light is flashing, momentarily connect the white wire to ground for >250mS and <1S (light will go steady high) then release. The flash pattern will advance to the next pattern. If the light module was at the last pattern, the pattern will reset to the 1st pattern.

**BACKUP PATTERN**

This function is only valid when the LED module is in a flashing mode (disabled in cruise or steady ON functions). When the light is flashing, momentarily connect the white wire to ground for >1S and <2S (light will go steady high, steady low) then release. The flash pattern will backup to the previous pattern. If the light module was at the first pattern, the pattern will change to the last pattern on the list.

**PATTERN RESET**

This function is only valid when the LED module is in a flashing mode (disabled in cruise or steady ON functions). When the light is flashing, momentarily connect the white wire to ground for >5S and <6S (light will go steady high, steady low, off, steady high, steady low, off) then release. The flash pattern will reset to the 1st pattern in the list.

**FACTORY RESET**

This function is only valid when the LED module is in a flashing mode (disabled in cruise or steady ON functions). When the light is flashing, momentarily connect the white wire to ground for >6S and <7S (light will go steady high, steady low, off, steady high, steady low, off, steady high) then release. The LED module will reset to: pattern=1, Function Table=1, Color Swap=OFF, Simultaneous.

**Backup High/Low Power**

To be compliant with government regulations, a Backup Light System consisting of Dual Backup Lights shall be operated in Low Power. A system consisting of one Single Backup Light shall be operated in High Power.

SETUP TABLE			
SECONDS		USER INTERFACE	
FROM	TO	VISUAL FEEDBACK	ACTION TAKEN
0	1	STEADY-HIGH (60%)	FORWARD ONE PATTERN
1	2	STEADY-LOW (30%)	BACKWARD ONE PATTERN
2	3	OFF	NO CHANGE
3	4	STEADY - HIGH (60%)	SEQUENCE TYPE: SIMULTANEOUS OR ALTERNATE
4	5	STEADY - LOW (30%)	NO CHANGE
5	6	OFF	RESET TO PATTERN 1
6	7	STEADY-HIGH (60%)	FACTORY RESET (PATTERN 1, COLOR SWAP: OFF, SIMULTANEOUS) SEPARATE COLOR CONTROL: OFF
<b>If held longer than 7 seconds, the light will go back to flashing the current pattern and no action will be taken.</b>			

**FLASH PATTERNS**

PATTERN #	SINGLE COLOR
1	QUINT
2	WARP
3	INTER-CYCLE
4	DOUBLE
5	QUAD
6	POWER PULSE
7	ROAD RUNNER
8	Q-SWITCH
9	STEADY-BURN / ROADRUNNER (SEQUENCE TYPE 1: STEADY BURN, SEQUENCE TYPE 2: ROADRUNNER)
10	STEADY-BURN DRIVER TITLE 13 QUAD (SEQUENCE TYPE 1: STEADY BURN, SEQUENCE TYPE 2: TITLE 13 QUAD)
11	QUAD 2
12	DOUBLE 2

**SYNC 2**

Synchronizing the flashing of multiple light modules is accomplished by connecting the Green wires of different light modules together. Up to 24 light modules can be connected for synchronized flashing. All light module flash patterns must be set to the same flash pattern # to ensure proper operation. Refer to Sequence Type section in the Setup Table to setup light modules to flash in alternate or simultaneous flash pattern.

**NOTE: Will NOT work with non-Sync 2 products, such as Ghost, LED3, and 4 wire Intersector. WILL WORK with Sync 2 products nFORCE Secondary Lights, nFORCE FIT, and 5 wire Intersector Lights**

with Clear Duty® Technology

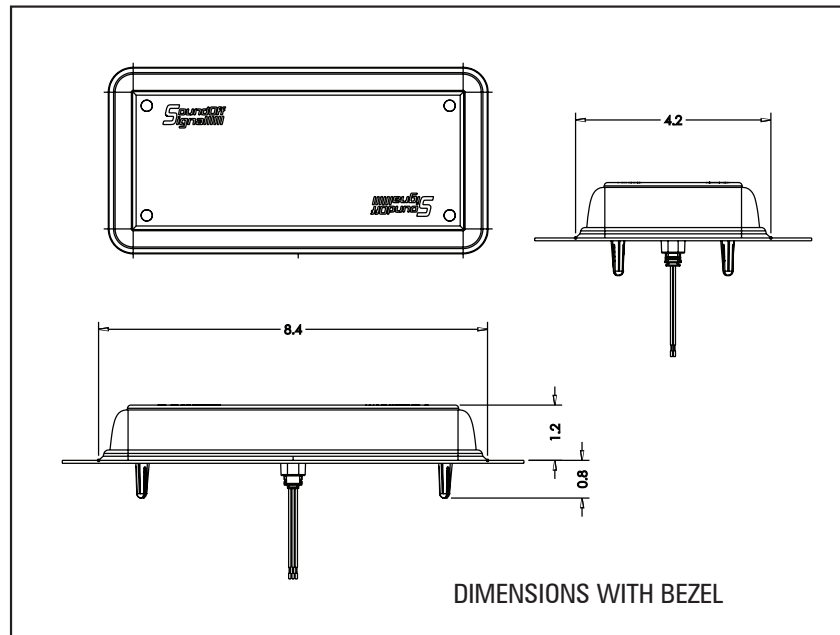
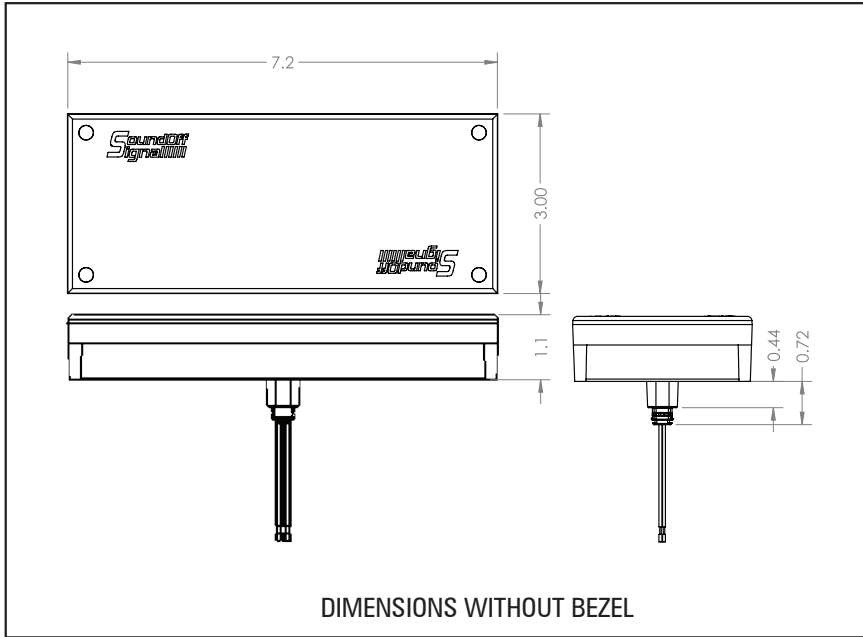

## BEZEL INFORMATION

### MPOWER® 7X3 DIMENSIONS

Overall Dimensions:	4.52"L x 0.92"H x 0.42"D
Overall Dimensions with Bezel*:	4.52"L x 0.92"H x 0.42"D

\*Single Bezels compatible with Stud & Screw Mount versions  
Triple and Quad Bezels compatible with Screw Mount versions only

### BEZEL PART NUMBERS

PMP8BZL04(xx)\*\* - Bezel, includes Gasket

PMP8HK01-(XX)\*\*\* - Hardware Kit

\*\*1st (x) Refers to the Single, Triple, Quad Selection

- 1 = Single Bezel
- 3 = Triple Bezel
- 4 = Quad Bezel

2nd (x) Refers to the Color of Bezel

- B = Black
- C = Chrome
- 4 = Quad Bezel

\*\*\*(XX) Refers to type of Hardware Kit

- BZ = Triple & Quad Bezel
- QM = for Quick Mount Application
- SM = for Screw Mount Application
- ST = for Stud Mount Application